

POWERFUL SWITCH BASED ON CX1525A THYRATRON

*I.A. Chertishev, M.V. Ivakhnenko, D.A. Kaplij, E.A. Khomyakov, A.I. Kosoi, V.Yu. Titov,
Yu.D. Tur, V.A. Tsymbal, E.I. Zajtsev, I.N. Zajtsev*

National Science Center "Kharkov Institute of Physics and Technology", Kharkov, Ukraine

E-mail: ch.igor@kipt.kharkov.ua

Thyratrons of obsolete types TGI1-2500/50, TGI1-2500/35, TGI1-5000/50 are used in modulators of NSC KIPT of as a switch, their service life has expired. To update the modulator we selected thyatron CX1525A of company EEV, which technical parameters met the requirements: switched current 2.3 kA, anode voltage up to 40 kV, pulse frequency up to 300 Hz, pulse duration 5 μ s. Thyatron switchboard based on CX1525A was de-signed and constructed. The results of study the switch operation in mode of active accelerator are reported.

PACS: 29.17.+w

INTRODUCTION

Hydrogen thyratrons intended for generation of high-voltage short pulses at high load currents are used as a switch in many plants. Hydrogen thyatron made of ceramic and metal as a rule has a heated cathode and a control grid. Pulse typical parameters are: duration – units of microsecond, anode voltage – kilovolt (up to 40 kV), switched current – units of kiloampere. Pulses are generated by quick connection a load to energy storage system, which is discharged completely in a time of pulse duration. The voltage in anode-cathode path becomes insufficient to maintain the discharge. In the course of discharging the capacitor of the energy storage system through thyatron and load resistance the voltage in anode-cathode path becomes insufficient to maintain the discharge. Electrons and ions diffuse to electrodes and vacuum shell walls, settle on their surfaces and recombine among themselves – plasma medium “decays” and the anode-cathode path restores its insulating properties. Connection is realized by the thyatron when relatively low-powered voltage pulse enters the control electrode. Modulators on hydrogen thyratrons have a number of advantages. They are simply constructed and have a high efficiency.

The switch is an important part of this plant. A number of requirements regarding peak operating voltage, peak switched current, average current etc. are imposed to it. So performance reliability of the plant [1, 2] depends on selection of a switch and its constituent parts.

EXPERIMENTAL SETUP

Modulators operated in NSC KIPT active accelerators are performed according to linear circuit with generating line depletion, through a pulse transformer. Simplified electric diagram of the plant is presented in Fig. 1. The PFN is charged through charging choke and diode from power supply. The PFN is discharged through TGI switch to primary winding of pulse power transformer of amplifying klystrons. In initial state before arrival of control voltage pulse the cathode is heated up to operating temperature and grid potential is zero (as to cathode). Anode potential is high (kilovolts), but it doesn't accelerate electrons emitted by the cathode due to low penetration factor of the grid. Voltage pulse of shape close to rectangular is generated on RL load as a result of PFN discharge. Pulse peak can be adjusted additionally by changing the parameters of generating line cells [3].

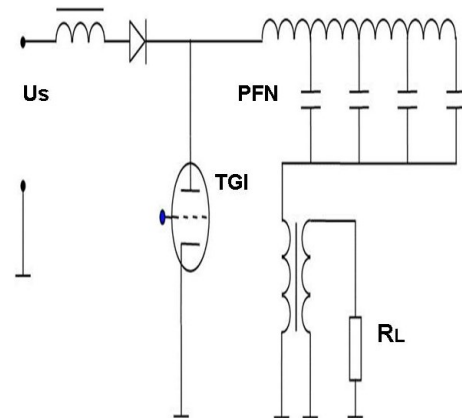

Fig. 1. Simplified electric diagram of the plant

Ceramic hydrogen filled thyratrons of type TGI1-2500/50, TGI1-5000/50 and TGI1-5к/45 were used as switches. However, most of thyratrons used in accelerators failed for some time past. Thyatron CX1525A of company EEV was selected to replace the exhausted thyratrons, as well as to update the modulator. Switch based on deuterium filled thyatron CX1525A was developed and implemented.

SELECTION OF A THYRATRON

Selection of a thyatron was carried out on the principle that to minimize a number of reconnections in modulator circuit. So the selected thyatron should have characteristics comparable to thyratrons used in the plant previously. The main technical parameters of thyratrons used in accelerator modulators before and parameters of thyatron CX1525A are presented in the. As seen in the Table the technical requirements for thyatron operation were met and the main reason of thyatron failure was the expiry of life. The main parameters of the selected thyatron are comparable to parameters previously used but the maximum switching frequency is higher. Besides, deuterium thyratrons CX1525A are more stable compared to conventional lamps. Thus, the new thyatron can be used in modulator circuit in case of connection diagram and lockouts updating. Assembly representation of thyatron CX1525A is presented in Fig. 2. The thyatron has two grids G1, G2, as well as gradient grid for distribution of anode potential over the surface. The thyatron has a ceramic case. The overall length is 50 mm.

Parameter name, units of measurement	CX1525A		TGI1-2500/50		TGI1-5000/50		TGI1-5k/45	
	Rating	Actual	Rating	Actual	Rating	Actual	Rating	Actual
Filament voltage, V	6.3	6	6...6.6	6.3	6.66	5.5	6.5	6.3
Filament current, A	37	37	76...94	85	2.2	190	30	29
Pulse anode voltage, kV	50		10...50	45	10...50	45	5...40	40
Pulse anode current, A	5000	2300	2500	2000	5000	2000	2500	2500
Average anode current, A	5	4	4	3	10	3	10	4
Pulse duration, μ s	50	5	30	5	16	5	0.2...50	5
Frequency, Hz	5000	300	400	300	125	300	5000	300
Cooling	Air 5 cube/min		Water 3 l/min		Water 15 l/min		Air 5 cube/min	

Diagram of thyatron grids connection is presented in Fig. 3. Hydrogen thyatron has a potential control with two grids. Trigger unit, which ensures feeding of pulses of voltage – 600...2000 V and duration – 0.5...2 μ s to two grids, is required to activate the thyatron. MA2709A trigger unit of company EEV is used to activate the thyatron.

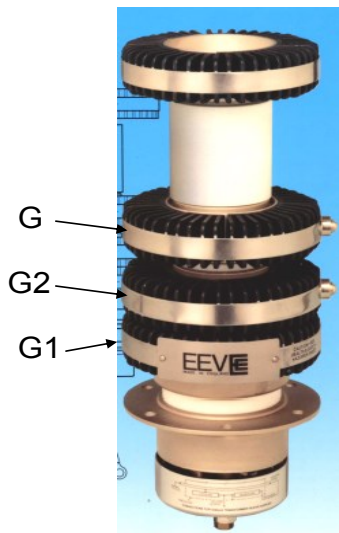

Fig. 2. Assembly representation of thyatron CX1525A:
G1 – the first grid; G2 – the second grid;
G – gradient grid

Structurally it is fastened on the switchboard. Cables connected to it are shielded. Signals from trigger unit are applied to thyatron grids G1, G2 via load resistors R1, R2. Suppressors are used to protect thyatron and trigger unit from noise pickups.

Transmitting cables from the trigger unit to the thyatron, as well as from the trigger unit to lockout monitoring system were roved through ferrite rings in order to avoid noises on triggering pulse or minimize them to the permissible value. Signals from trigger unit through dividers R_{d1}, R_{d2} are transmitted to lockout monitoring system. Locking is performed so that the system will not start if at least one grid signal does not enter the lockout monitoring system. Locking of airflow (cooling) system is executed in the same way. Isolating transformers are installed on transmitting cables at the modulator output. Galvanic isolation of thyatron grids and output circuits of the trigger unit and lockout monitoring system are involved.

Positive voltage of ~ 500 V is applied to the first grid providing an auxiliary discharge between cathode and the first grid. The first grid has low resistance rela-

tive to the second grid, electron flow between grid 1 and grid 2 increases when a pilot spark burns on the first grid. A signal having a pulse height (amplitude) of ≈ 100 V, durability of $\approx 0.5 \mu$ s, delayed for $\sim 0.5 \mu$ s in relating to the first pulse is applied to the second grid. Negative bias of ~ 150 V is applied to the second grid. This diagram of thyatron connection ensures increasing of cathode service life.

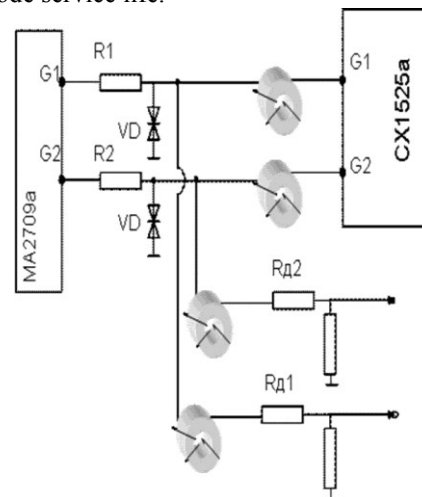

Fig. 3. Diagram of connection of thyatron grids

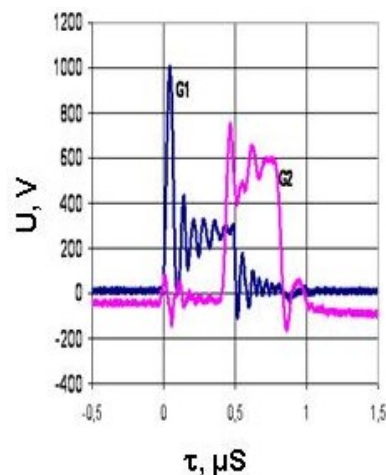

Fig. 4. Signals on thyatron grids: G1 – the first grid;
G2 – the second grid

Voltage pulses on grids at heated thyatron are presented in Fig. 4. The resistance of the first grid is ~ 7 Ohm. The resistance of the second grid is ~ 50 Ohm. Voltage pulse on the second grid is 500...600 V, it is slightly weaker. Voltage pulse on the first grid has sharp edge enough (~ 10 kV/ μ s), it ensures stable operation of

the switch. Voltage pulse on the second grid has negative shift and delay relative to the pulse from the first grid. Thus, the required conditions for reliable actuating of thyratrons are observed.

Diagram of the thyatron connection is presented in Fig. 5. CX1525A has two grids: G1 loaded on resistance ~ 5 Ohm, G2 loaded on resistance ~ 50 Ohm and a gradient grid. Gradient divider comprises resistance-capacitance divider R1-C1 (R1= 500 Ohm, C1 ~ 600 nF) and ohmic divider R2 (18 MOhm, with total dissipated power of ~ 10 W), this divider is required for potential distribution up to 40 kV over the thyatron surface (external and internal). It renders possible to avoid or minimize the probability of disruptive discharge over the surface. C2, C3 are filtering capacities.

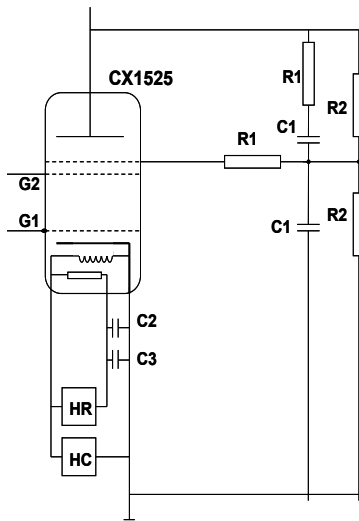

Fig. 5. Diagram of the thyatron connection

TRIGGERING OF THE SWITCH

After analysis and measurement of technical parameters of the thyatron and the trigger unit and study the regulations for their connection the modulator of the accelerator KUT-1 was triggered in operation mode. For this purpose the lockouts were manufactured or updated, as well as noises were reduced to the level required for reliable operation of the accelerator. Noises were suppressed by shielding of components of the thyatron switchboard. Transformer of hydrogen generator and metering circuit were placed into the shield. Isolating transformers were installed on transmitting cables as they leave modulator. Cathode ground was insulated from common ground.

Voltage and current pulses at modulator output, as well as initiation pulse in accelerator operation mode after elimination of the noise pickups were presented in Fig. 6.

The following mode was obtained: voltage $U = 200$ kV, klystron current $I_m = 140$ mA, frequency $F = 200$ Hz.

Accelerator LU-10 was triggered on thyratrons CX1525A. Diagram thyatron connection was similar except for trigger unit. Instead of factory installed trigger unit we used two on hand trigger units connected via delay circuit, which had been used earlier in modulators when operated with single-grid thyratrons TGI1-5000/50 and TGI1-2500/50. Diagram of connection of trigger units and pulses at their outputs are presented in Fig. 7.

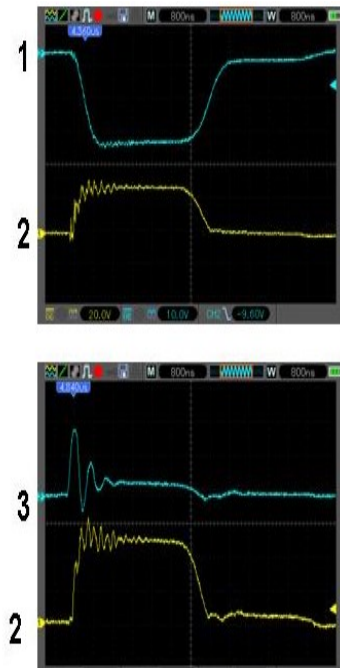

Fig. 6. Voltage pulse (1) at modulator output, current pulse (2) and initiation pulse (3) in operation mode. After elimination of noise pickups

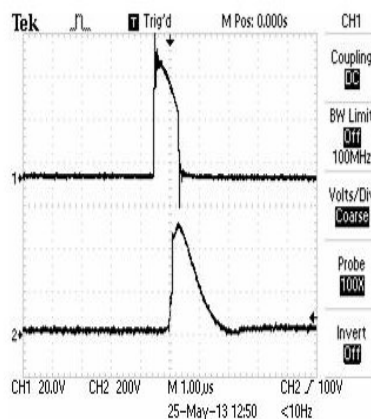
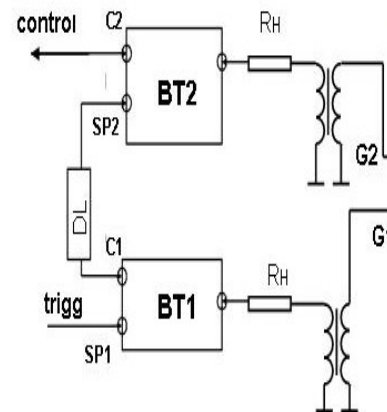

Fig. 7. Simplified block diagram of connection of thyatron grids on LU-10 and pulses from trigger blocks

Amplitude from trigger units (BT1, BT2) had a value specified in thyatron technical requirements (~ 1200 V).

Triggering signal was applied to the input of the first trigger block SP1. This signal was applied to the grid 1 from the output of the first trigger block through resistor 27 Ohm and network decoupling transformer. Signal

from the output of lockout monitoring system of the first trigger unit C1 was applied to the input of the second trigger unit SP2 through the delay line DL. Delay time was 0.5 μ s. Signal from the output of the second unit, as well as for the first trigger unit, was applied to the second grid through resistance of 27 Ohm. The pulse from the output of lockout monitoring system entered the lockout system. When one of trigger units failed, then monitoring pulse did not enter locking circuit preventing modulator triggering in such way.

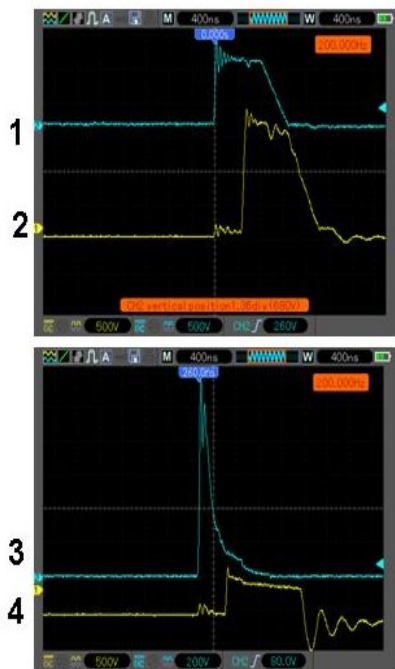

Fig. 8. Pulses from the output of trigger block:
1 – grid 1; 2 – grid 2 and pulses on grids
of thyatron 3 grid 1; 4 – grid 2

The following operation mode was obtained on the accelerator LU-10: voltage $U_2 = 250$ kV, klystron current $I_m = 150$ mA, frequency = 250 Hz.

Trigger unit for two-grid thyatron was performed on basis of trigger unit MA2709A. The functions of trigger unit were enlarged – monitoring of both signals availability was added. Galvanic isolation of output circuits trigger block and grids CX1525A was provided. Pulses from trigger unit and pulses on thyatron grids were presented in Fig. 8.

Modulator based on the new trigger unit was actuated in operation mode of the accelerator KUT-1.

CONCLUSIONS

In the course of executed work:

Triggering of the modulator based on the thyatron CX1525A and MA2709A trigger unit was carried out.

Switch operation was analyzed, diagram and construct of trigger unit were developed, design documentation was worked out and switchboards with trigger unit, cooling system and high-voltage anode divider were manufactured.

Switches on basis of thyatron CX1525A were actuated in operation mode of accelerators KUT-1, EPOS, LU-10. Parameters and technical requirements of the thyatron were studied and thyatron and the trigger unit operability were checked.

REFERENCES

1. V.D. Bochkov, Yu.D. Korolev. Pulse gas-discharge switching devices // *Encyclopaedia of low temperature plasma» release* / V.E. Fortov, Book.4. M.: "Nauka". 2000, p. 446-459.
2. V.D. Bochkov, Yu.D. Dyagilev, Yu.D. Korolev. Powerful switchboards of current with LP of gas // *DTE*. 1998, №5, p. 91-95.
3. I.V. Kazarezov, A.A. Korepanov. Matching of the parameters of Pulse Forming Networks (PFN) and pulse transformers in quantizer circuits for power supply of high-power klystrons // *PAST*. 1999, №4, p. 44-45.

Article received 25.03.2014

КОММУТАТОР НА ОСНОВЕ ТИРАТРОНА CX1525A

И.А. Чертищев, М.В. Ивахненко, Д.А. Каплий, Е.А. Хомяков, А.И. Косой, В.Ю. Тимов, Ю.Д. Тур, В.А. Цымбал, Е.И. Зайцев, И.Н. Зайцев

В модуляторах ННЦ ХФТИ в качестве коммутатора используются тиратроны типа ТГИ1-2500/50, ТГИ1-2500/35, ТГИ1-5000/50, ресурс которых исчерпан. Для модификации модулятора выбран тиратрон CX1525A производства фирмы EEV, по техническим характеристикам удовлетворяющий параметрам: коммутируемый ток 2,3 кА; анодное напряжение до 40 кВ; частота посылок до 300 Гц; длительность импульса 5 мкс. Проведена разработка и изготовление тиратронной стойки на основе CX1525A. Приведены результаты исследования работы коммутатора в режиме действующего ускорителя.

КОММУТАТОР НА ОСНОВІ ТИРАТРОНА CX1525A

І.О. Чертіщев, М.В. Ивахненко, Д.О. Каплий, Е.А. Хомяков, О.І. Косой, В.Ю. Тимов, Ю.Д. Тур, В.А. Цимбал, Е.І. Зайцев, І.М. Зайцев

У модуляторах ННЦ ХФТИ в якості комутатора використовуються тиратрони типу ТГІ1-2500/50, ТГІ1-2500/35, ТГІ1-5000/50, ресурс яких було вичерпано. Для модифікації модулятора було вибрано тиратрон CX1525A виробництва фірми EEV, який по технічним характеристикам відповідає параметрам: комутуємий струм 2,3 кА; анодна напруга до 40 кВ; частота посилок до 300 Гц, тривалість імпульсу 5 мкс. Проведена розробка та виготовлення тиратронної стойки на основі CX1525A. Приведено результати дослідження роботи комутатора в режимі діючого прискорювача.