

INPUT COUPLER DEVELOPMENT FOR SUPERCONDUCTING CAVITY 500 kW CW POWER FEED

M.A.Gusarova¹, A.A.Zavadtsev², D.A.Zavadtsev², A.A.Krasnov¹, M.W.Lalayan¹, N.P.Sobenin¹
¹Moscow Engineering Physics Institute (State university)

²Introscon Inc.

E-mail: sobenin@mail.ru

The coaxial-type input coupler for Energy Recovery Linac injector cavity simulation results are presented. This device is to feed the superconducting cavity with 150 kW RF power in continuous wave regime at 1.3 GHz operating frequency. The thermal simulation was done for the modified coupler able to transmit the RF power up to 500 kW. Different designs with heat load to injector cryogenic system lowered and external Q-factor adjustment were considered.

PACS: 41.20.Jb, 29.20.Dh

1. INPUT COUPLER DESIGN CHALLENGES

The upgrade plans of Energy Recovery Linac (ERL) include the boost of injector cavity electromagnetic field strength. This makes the input power coupler to dependably transmit substantially increased RF power from distribution system to accelerating cavity. The RF power increase up to 500 kW in continuous wave regime is challenging. The existing twin coaxial-type coupler was developed for operation at 150 kW power (75 kW per each unit). The input power increase for the cavity is not a simple scaling task. The existing coaxial input coupler design has physical limits. Further power increase needs the use of new technical solutions.

The most troublesome issue presented by the development of raised performance coupler was to keep the thermal load introduced by it to cryogenic system. The set of numeric codes (Microwave Studio and HFSS) were used to ensure the coupler electrodynamic properties are within certain limits determined by ERL injector design. The coupler matching was done for each design considered while external quality factor adjustment range kept in mind.

To get the data on coupler thermal properties on certain RF power level the simulations were done using the ANSYS code supplied with custom-made routines allowing to link both the thermal and electrodynamic problems.

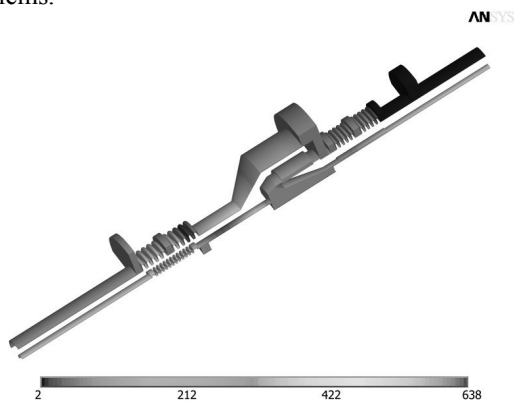

Fig.1. Temperature map of existing design coupler

Fig.1 shows simulated temperature distribution for the coaxial line for the case of 250 kW CW power transferred through coupler designed for 75 kW operation.

The simulation was done using the ANSYS code. It is seen that the bellows especially the “warm” one has the excessive temperature. The long bellows having rather thin walls could hardly provide sufficient heat flow and it causes insufficient bellows middle area cooling. Moreover, both the heat conductivity is reduced and the copper resistance increased with temperature growth thus leading to the extra heat generation. At this power level the antenna tip temperature also rises. This could lead to heat flow to cavity cryogenic zone growth due to infrared radiation from antenna tip. The heat loads to different cryogenic zones are presented in Table 1.

Table 1. Existing design coupler heat loads

Helium, 2 K	0.65 W
Helium, 4.2 K	6.6 W
Nitrogen, 80 K	355.0 W

The bellows overheating could be avoided by another (third) outer bellows added into the design as a nitrogen-cooled heat sink. But this leads to more complex design. The antenna tip heating could be diminished by making its shaft solid or at least tube shaped with thick walls. As the side effect this will increase the antenna weight and the extra stress to the ceramics appears.

As the result, the maximal transferred power for the existing coupler design is limited to 100...150 kW CW (200...300 kW CW for twin coupler).

2. SINGLE BELLOWS COUPLER DESIGN

With transmitted power increase the bellows became the performance limiting elements. Nevertheless, they could not be excluded from the design because the antenna tip must be movable to provide the external quality factor tuning. The single bellows design is proposed as the optimal way to overcome the problems specified. It is based on the similar one evaluated earlier as concept for TESLA coupler. The only bellows is located in inner conductor in “cold” area. Fig.2 presents the simulated temperature distribution for the 250 kW CW power transmitted. The heat flows to different cryogenic zones are summarized in Table 2.

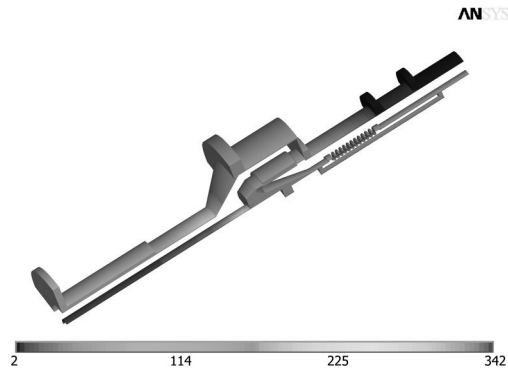

Fig.2. Temperature map of coupler coaxial part with single bellows

Table 2. Single bellows coupler heat loads

Helium, 2 K	0.55 W
Helium, 4.2 K	9.6 W
Nitrogen, 80 K	178.7 W

This coupler bellows is to be liquid or gas nitrogen cooled during the operation. It can be done by pumping nitrogen from doorknob side or to use coaxial stub located in the area of former “warm” bellows. The other way to decrease bellows temperature is to split it with additional heatsink added in between having low thermal resistance to shaft, as it has been done with outer bellows in current design.

The further design improvements are in thermal decoupling optimization between nitrogen and helium cryogenic zones along with the possible bellows position alteration. The coaxial line inner conductor cooling system is also to be studied.

Also, as a possible way to decrease bellows heat losses is to use shorter bellows. But there are severe requirements for external quality adjustment and therefore antenna movement range [2]. Additionally, the bellows has limited squeeze and extension ability. Therefore, bellows length reduction under certain limit is hardly achievable. Further bellows length diminishing could be done with antenna yielding the same Q_{ext} adjustment range by reduced traveling provided by its shape changed.

3. LOOP-CAPACITIVE COUPLER

Fig.3 presents the loop-tipped antenna coupler conceptual design. External quality factor value is adjusted by capacitive gap between inner conductor and

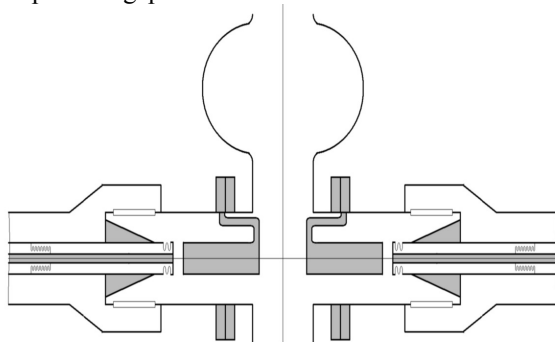

Fig.3. Loop-capacitance coupler design

antenna tip variation. The most preferable way is to use superconducting antenna. It can be made of bulk niobium, or niobium plated stainless steel. This leads to considerable reduction of heat loads to liquid helium area. The overall inner conductor length is reduced by antenna tip separation. So, the heat flow to nitrogen cryogenic zone and ceramic window mechanical stress will be reduced.

The coupler electro-dynamical simulation and optimization were done using HFSS code. The external quality factor could be obtained using known formula

$$\frac{1}{Q_L} = \frac{1}{Q_{ext}} + \frac{1}{Q_0}$$

In case of loss-free cavity Q_0 is infinite and external Q-factor equals to loaded quality. Thus external quality factor value could be obtained from reflection on frequency dependence for arbitrary port. The external quality factor dependence on gap width is presented on Fig.4.

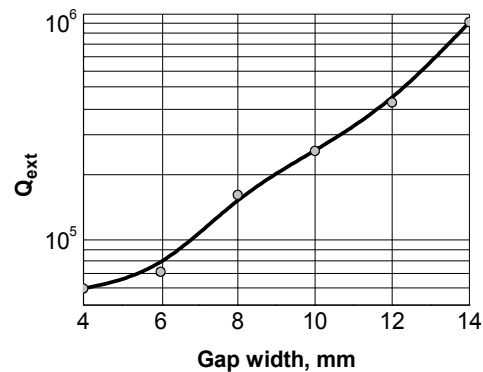

Fig.4. Dependence of Q_{ext} of a twin coupler on the gap width

As it could be seen the external quality factor ten times variation is achieved with 10 mm gap width change. The latter value could be lowered with an antenna of modified shape. The coupler featuring lowered movement range yielding high Q_{ext} adjustment could be designed and manufactured. The movement precision is achievable by fine treaded screw. Traveling range reduction will allow the shorter bellows used thus the entire central conductor assembly will be more rigid and its side play will be substantially lower.

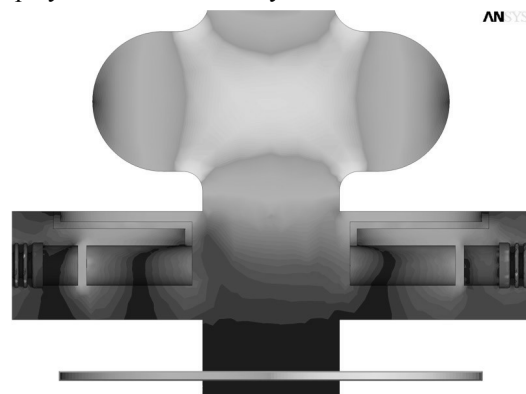

Fig.5. Antenna electric fields distribution

Fig.5 shows the electric fields distribution in coupler to cavity transition area.

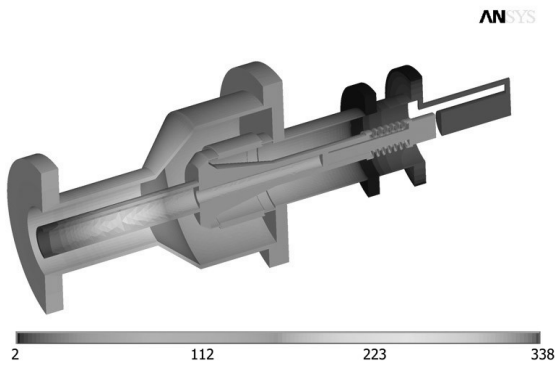

Fig.6. Temperature map of loop-capacitance coupler

Fig.6 presents the simulated temperature distribution for the 250 kW CW power transmitted. The heat flows to cryogenic zones are summarized in Table 3.

Table 3. Loop-capacitance coupler heat loads

Helium, 2 K	0.79 W
Helium, 4.2 K	10.6 W
Nitrogen, 80 K	119.8 W

Heat flow to the helium cryogenic zone is greater than in previous design. It is caused by losses on antenna surface having direct connection with cavity flange. Minor thermal load to the 4.2 K zone variation is caused by changes in coupler design having outer conductor length changed.

CONCLUSION

The existing coupler design for ERL injector cavity confining with respect to transmitted power are evaluated. The elements limiting the coupler thermal performance are determined.

Two ways of coupler performance improvement by coupler design modification are proposed. The first one is mainly based on the existing design with antenna tip unchanged. More appreciable transmitted power increase is achieved by the second coupler design proposed having fixed loop shaped antenna tip and capacitive Q_{ext} tuning assembly.

REFERENCES

1. A. Krasnov, N. Sobenin, S. Belomestnykh et al. *Thermal Calculations of Input Coupler for ERL Injector*. Proc. of the XIX RuPAC, Dubna. 2004.
2. V. Veshcherevich, I. Bazarov, S. Belomestnykh et al. *Input coupler for ERL injector cavities*. Proc. of PAC 2003, Portland. 2003.

РАСЧЕТ УЗЛА ВВОДА МОЩНОСТИ ДО 500 кВт В СВЕРХПРОВОДЯЩИЕ РЕЗОНАТОРЫ

М.А. Гусарова, А.А. Завадцев, Д.А. Завадцев, А.А. Краснов, М.В. Лалаян, Н.П. Собенин

Приведены результаты моделирования коаксиального устройства ввода СВЧ-мощности в сверхпроводящий резонатор линейного ускорителя электронов с рекуперацией энергии (ERL). Устройство обеспечивает ввод 150 кВт мощности в непрерывном режиме на частоте 1.3 ГГц. Приведены результаты тепловых расчетов модифицированного устройства, способного передать мощность до 500 кВт. Рассмотрены различные варианты конструкции, обеспечивающие регулировку величины связи и создающие минимальные тепловые нагрузки на криогенную систему.

РОЗРАХУНОК ВУЗЛА ВВЕДЕННЯ ПОТУЖНОСТІ ДО 500 кВт У НАДПРОВІДНІ РЕЗОНАТОРИ

М.А. Гусарова, А.А. Завадцев, Д.А. Завадцев, А.А. Краснов, М.В. Лалаян, Н.П. Собенин

Наведено результати моделювання коаксиального пристрою введення НВЧ-потужності в надпровідний резонатор лінійного прискорювача електронів з рекуперациєю енергії (ERL). Пристрій забезпечує введення 150 кВт потужності в безперервному режимі на частоті 1.3 ГГц. Наведено результати теплових розрахунків модифікованого пристрою, здатного передати потужність до 500 кВт. Розглянуто різні варіанти конструкції, що забезпечують регулювання величини зв'язку і створюють мінімальні теплові навантаження на криогенну систему.