

# THE TUNING METHOD OF THE BIPERIODIC ACCELERATING STRUCTURE OF ELECTRON LINEAR ACCELERATOR

*I.O. Chetverikov, D.V. Slyusar, V.V. Terent'ev*

*NIIEFA D.V. Efremov Scientific Research Institute of Electrophysical Apparatus*

*St-Petersburg, Metallostroy, Ave. Sovetsky 1, Russia*

*e-mail: NPK LUTS @ NIIEFA. SP.SU*

Providing the operating mode of the accelerating structure requires controlling the resonant frequencies and coupling coefficients between the cells. Single cell of the accelerating structure is the high quality resonator. For the cell fine-tuning it is necessary to observe the boundary conditions given by presence neighbor cells. In this paper the description of arrangement modeling these boundary conditions and the methods of frequency and coupling coefficients measuring are presented. The developed methods are universal for tuning of the biperiodic linear accelerator structures, which have different operating frequencies.

*PACS numbers: 29.17.+w*

## 1 INTRODUCTION

To obtain more effective using of the accelerating structure length and to provide the operating mode of the accelerating structure it is necessary to control the resonant frequencies and coupling coefficients between the cells. It is desirable that the frequency detuning of one cell was less than 0.01%. At present the calculations with such small errors are not possible.

To achieve this high frequency precision of the manufactured cells, it is necessary to carry out correct measurement at the constant temperature and proper mechanical pressure for guarantee of good contact between the metal surface.

The measurements of the amplitude field ratios in the accelerating structure are made for tuning of the coupling slots. Especially it is important in the buncher part of the accelerating structure to achieve required bunch parameters.

In that way, the tuning of cell frequencies and coupling coefficients of linear electron accelerator cells is a long process with a lot of measurements.

## 2 THE METHOD OF CELL FREQUENCY TUNING

The first step of the cell tuning procedure on the operating frequency is a measurement at resonant frequency of the cell. Having been defined cell resonant frequency inner diameter is machining for decreasing frequency on the corresponding value. Such manner of the tuning procedure presumes that at the beginning of the tuning there is some frequency reserve. The reserve is diminished in the series machining of the inner diameter. The initial reserve is determined by calculating error value and it is 20 MHz [1].

The basic problem of this tuning scheme is the frequency measuring phase. The accelerating structure cell is the high quality resonator. The precision tuning of cell resonant frequency requires to meet the boundary conditions, which are formed by influence of the neighbor cells of the resonator tested. Thus, it is necessary to develop the measurement methods, which will simulate such boundary conditions and allow to measure fre-

quencies of a separate cell or assembly of cells at low power level.

The suggested scheme of the accelerating structure cell measurements is shown in Fig. 1a. Neighbor cells (2, 4) directly define the boundary condition for the measuring cell (3). Because of the shorting cylinder there is no resonance in the neighbor cells. The influence of the coupling slots on the resonant frequency is the same as inside the real structure. Hence separate cell frequencies are measured.

## 3 THE METHOD OF COUPLING COEFFICIENTS TUNING

A method of coupling coefficients tuning in the accelerator is rather difficult. Coupling coefficients are tuned by pairs in each cascade. Successful tuning provides optimal field ratios in the accelerator cells.

The field ratios along the main part of accelerating structure are equal to 1. That occurs when the slots in cascade have the same lengths, and in this case the tuning is not difficult. Problems arise in the injector area, where the amplitude ratio between successive accelerating cavities can be as high as 4. A permissible tolerance of the field value is about 2%. This tolerance is much higher than that of frequency, but even this error requires a number of measurements and coupling slot adjustments to be performed before it can be achieved.

The measurement scheme of the coupling slots in the accelerating structure is shown in Fig. 1b. The small metal bead (5) is inserted into the cascade of the cells (2, 3, 4) and detunes the cascade resonant frequency. The ratio of the frequency deviation when detuning metal bead move along the cascade axis defines the field amplitude ratio.

## 4 CONCLUSION

Suggested measurement scheme is universal one for a resonator tuning of the biperiodic and combined accelerating structures operating in the  $\pi/2$  mode in the wide frequency range. It allows with great accuracy to model boundary conditions stipulated by the influence of the neighbour cells on the resonator frequency, and to re-

duce to a minimum errors, caused by feeding and measurement devices.

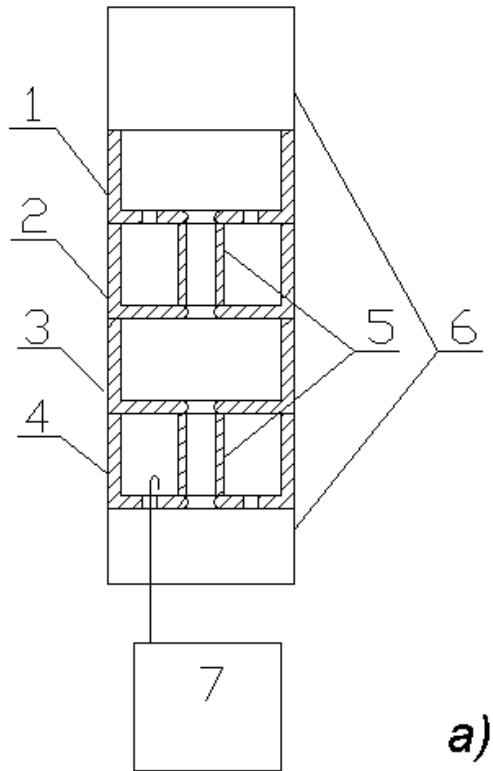

Fig. 1a. The scheme of frequency measurement of single cell (1, 2, 4 – neighbor cells, 3 – cell tested, 5 – shorting cylinders, 6 – absorbing cavities coated by al-sifer, 7 – analyzer).

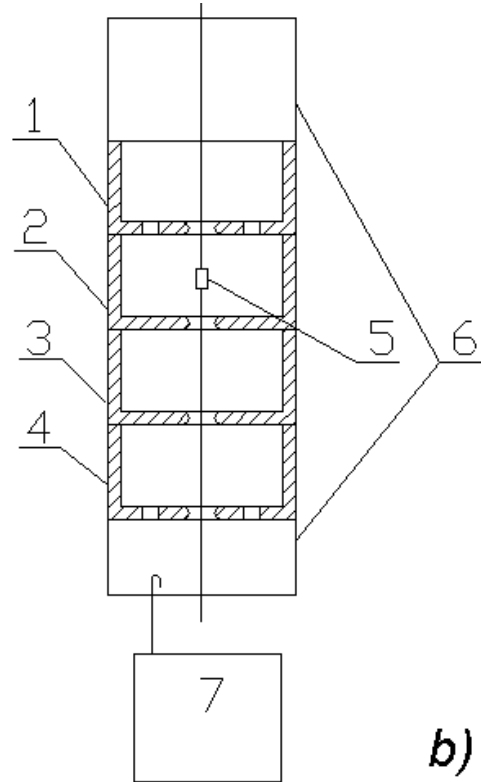

Fig. 1b. The measurement scheme of the coupling coefficient in the accelerating structure (1 – neighbor cell, 2, 3, 4 – cells of cascade tested, 5 – small metal detuning bead on the thread, 6 – absorbing cavities coated by al-sifer, 7 – analyzer).

The developed method of the frequency tuning is successfully employed in production of the different types of the accelerators. This method for tuning RF-parameters of the accelerator makes manufacture process faster and allows to improve quality of the production. Measured parameters of the accelerating structures at high power level are found to be in a good agreement with the results obtained via field distribution and beam dynamics simulation for self-consisted high frequency

fields.

## REFERENCES

1. I.O.Chetverikov, O.L.Maslennikov, V.V.Terent'ev. Using the Finite Element Method while Design the Linear Accelerator Structure // *Proc. XVII All-Russia Workshop on Charged Particle Accelerators*, Protvino, 2000. (in Russian).