

# HIGH-TEMPERATURE METALLIC CATHODE FOR RF GUN

*E.Z. Biller, I.V. Khodak, V.A. Kushnir, V.V. Mitrochenko,  
L.K. M'akushko, D.L. Stepin, V.F. Zhiglo  
NSC KIPT, Kharkov, Ukraine  
e-mail: [khiv@kipt.kharkov.ua](mailto:khiv@kipt.kharkov.ua)*

In the paper a metallic thermionic cathode with an electron beam heating to be used in RF gun is proposed. The high-temperature metallic emitter made of high-melting material will allow to decrease significantly the pulse current growth and to increase pulse repetition rate. The electron-optic system of the heating gun provides a beam current density at the plane of the heated emitter that is enough for its heating up. Simulation showed that at the heating beam power of 75 W, the emission current from the tantalum emitter surface would be about 150 mA. The cathode assembly prototype has been designed and results of its pilot tests are described.

*PACS numbers: 29.25.Bx, 41.85.Ar*

## 1 INTRODUCTION

Radiofrequency electron sources (RF guns) have been recently very common used in high-energy research accelerators as well as in various applied accelerators. RF guns permit to obtain intense high-brightness electron beams. However, RF guns with thermionic cathodes are featured by the cathode back electron bombardment inducing the cathode heating-up during a RF power supply pulse that results in a rise of the output current of the gun. Cathodes with a low operating temperature (800°-1400°C), commonly used in such guns, limit their application in linear resonance electron accelerators due to the cathode overheating when operating in a high average current mode (pulse repetition rate usually not exceeds a few tens of pulses per second).

There is some experience to reduce the back electron bombardment effect [1-3]. A method we propose to reduce the influence of bombardment effect on output beam performances of a RF gun consists in using a thermionic cathode with high work function. A metallic emitter heated to high temperature by an electron beam of an additional heating-up gun can be used as well. It will permit to decrease the rise of output current as well as to increase the pulse repetition rate. We aim to reach pulse repetition rate of 50 pps at least.

The paper represents the design of a cathode assembly for the multipurpose two-cavity RF gun [4]. The cathode assembly includes a diode heating-up electron gun of the metallic emitter. The paper describes the calculation of the electron-optic system of this gun and beam temperature distribution in the metallic emitter. Design features of the cathode assembly and results of pilot tests are also considered.

## 2 CALCULATIONS

High operating temperature of the RF gun cathode decreases the relative temperature variation under back electron bombardment and as result decreases the change of the emission current. For example the temperature variation of cathodes in 100°C causes the emission current growth in 100 % for a high-temperature emitter (work function is equal to 4.2 eV) and in 300% for the low-temperature emitter (work function is equal to 1.8 eV). In the above example the Schottky effect was

taken into account for typical values of the electric field near a cathode in the thermionic RF guns. The heating cathode power is increased under application of the high-temperature cathode that permits its operation under high value of average back bombardment power.

It is assumed the RF gun operation with a pulse current of 50-100 mA at its output. Taking into account electron losses in the gun cavities, the current of the metallic cathode should be ~ 100-150 mA. Size of the emitting surface should not be higher of 3 mm in diameter.

Comparative analysis of emission properties of various materials has shown that tantalum is most suitable for given requirements.

Solving of the heat conduction equation with boundary conditions taking into account radiant heat transfer we carried out the estimation of a heating beam power, under which the required emission current can be produced. The blackness factor of the material was taken equal to 1 to estimate the maximum heating power to obtain a required temperature. The temperature distribution on a surface of the tantalum emitter having 5 mm in diameter and 0.3 mm in thickness was computed for various heating power values. Temperature distributions obtained for the three values are shown in Fig. 1.

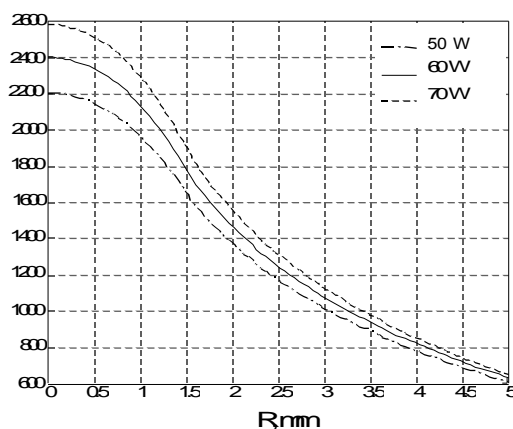

*Fig. 1. Temperature distribution versus emitter surface.*

Integrating the emission current density over the emitter surface allows obtaining the emitted current as a

function of the heating power. Computed results are shown in Fig. 2.

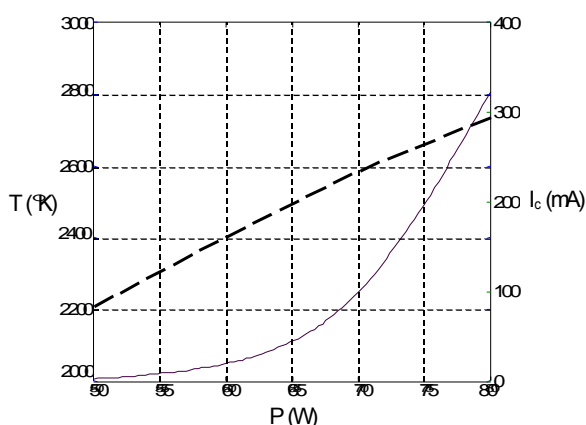

Fig. 2. Temperature in a center of the emitting surface (---) and emission current (—) versus heating power.

Analysis of emitted current distribution over the surface shows that a diameter of an emitting spot actually is not more than 3 mm.

Calculation shows that the heating beam power is no higher than 80 W. Nevertheless, this value was accepted of 90 W for the design of the heating-up electron gun to have some reserve of power.

The heating-up gun was designed on the basis of the needed heating power and hardware features of the RF gun cathode assembly. The flat cathode of 2.8 mm in diameter is used in the heating-up gun. Therefore the beam compression ration should be 1 or little higher. Geometry of the electron-optic system of the gun was calculated using the EGUN code [5]. The final geometry of the heating-up gun is shown in Fig. 3 where the beam envelope is shown too. Herein the position  $Z=0$  corresponds to the cathode position and the position  $Z=18$  corresponds to the position of the tantalum emitter.

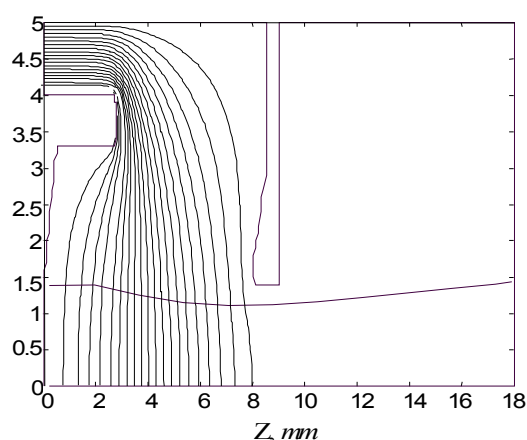

Fig. 3. EGUN simulation of heating-up electron gun.

The gun produces a laminar electron beam with uniform current density distribution on the cathode surface.

The ratio of the current density between edge and center of the cathode is 1.05 and the maximum current density is  $0.48 \text{ A/cm}^2$ . The geometry obtained permits the gun to produce the electron beam with a maximum current of 30 mA, perveance of  $0.187 \cdot 10^{-6} \text{ A/V}^{3/2}$  under the anode voltage of 3 kV. Fig. 4 shows the transverse electron beam profile at the plane of tantalum emitter re-computed using the results of EGUN simulation.

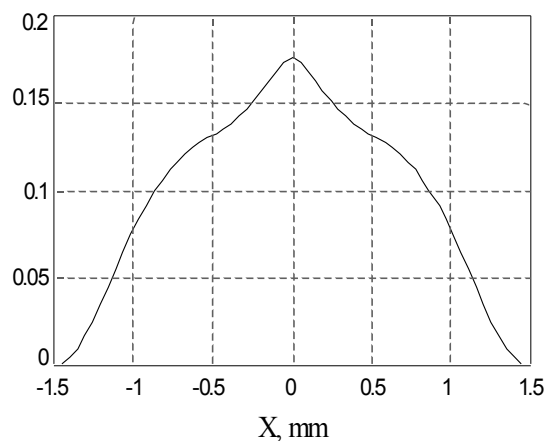

Fig. 4. Transverse beam profile at the tantalum emitter plane.

Summarizing calculated results, accepted were parameters of the heating-up gun and tantalum emitter which are tabulated in Table 1.

Table 1

Emission current of tantalum emitter, mA	100-150
Heating-up power, W	Up to 90
Maximum current of heating-up gun, mA	~30
Perveance, $\cdot 10^{-6}$ , $\text{A/V}^{3/2}$	0.187
Maximum anode voltage, kV	3
Beam compression ratio	~1

### 3 CATHODE ASSEMBLY DESIGN

The designed hardware combines hardware properties that are featured for both diode electron guns and cathode assemblies for RF guns. First ones are as following: electric reliability, accuracy in manufacturing and mounting the elements of a gun electron-optic system. In the second case, the importance is in the possibility of RF gun resonance system tuning by a cathode moving in the longitudinal direction.

Calculated overall dimensions of the heating-up gun permitted to place it in the safety tube applied in RF gun (see Fig. 5) and to use the tube as an anode. Tantalum emitter is placed at the safety tube face. Seeing that safety tube can move in the longitudinal direction the heating-up gun is rigidly fixed with safety tube holders. When assembling, cathode is rigidly fixed with the focusing electrode and, further, is rigidly fixed relatively to the anode. The cathode together with focusing electrode is insulated from the anode by cylindrical insulating

inserts that except temperature distortions besides the insulation.

Because the heating-up gun is in closed volume the safety tube has additional holes for a vacuum pumping down. Cathode based on the impregnated tungsten emitter is applied in the heating-up gun that gives the low filament power.

The cathode assembly hardware is enough compact. Overall longitudinal dimension of the assembly is no higher then 170 mm.

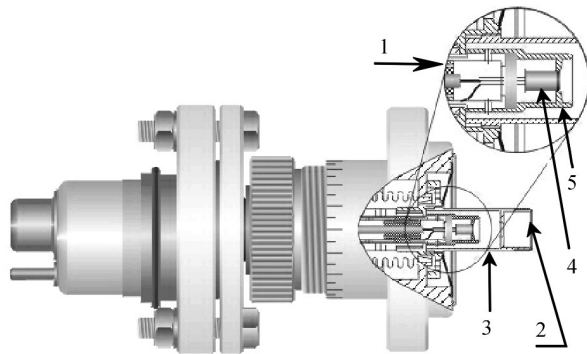

Fig. 5. Cathode Assembly Design:  
1 - heating-up gun, 2 - tantalum emitter, 3 - safety tube (anode), 4 - cathode, 5 - focusing electrode.

#### 4 PILOT TESTS

After being assembled the cathode unit was installed on the test set-up and was tested under an anode voltage of 3 kV. Then the current of heating-up gun of 20 mA was obtained. Temperature was measured using the optic pyrometer. Under an anode voltage of 3 kV the temperature of the tantalum emitter surface localized by the beam of the heating-up gun was  $\sim 2300^{\circ}\text{K}$ . Size of this surface was controlled visually by its bright glow and was no higher then 3 mm in diameter. Vacuum in the test set-up was no lower then  $10^{-6}$  torr during tests.

Regardless of the fact that obtained temperature of the tantalum emitter is some lower that needed one it is possible to start experiments with cathode assembly in-

stalled into the RF gun. Back electron bombardment will create additional source of tantalum emitter heating-up therefore we hope to reach needed output current. The experiments will start in near future.

#### 5 CONCLUSION

Application of the electron emitter with a high operating temperature permits to reduce influence of the back electron bombardment effect on the RF gun beam parameters.

The compact cathode assembly based on the tantalum emitter heated by an additional electron beam was designed and manufactured for the multipurpose RF gun. Pilot tests of the cathode assembly have shown that electron heating-up provides the cathode temperature proximate to the calculated one.

Further investigations of the metallic emitter will be held after its mounting in the RF gun.

#### REFERENCES

1. V.A.Kushnir, V.V.Mitrochenko, Wang-Gang. Reducing the back bombarding effect in a thermionic RF-gun // *Proc. of 14 Workshop on Charged Particles Accelerators*, Protvino, 1994, v. 3, p. 97-102.
2. C.B.McKee and John M.J. Madey // *Nuclear Instruments and Methods in Physics Research*. 1990, A296, p. 716-719.
3. V.V.Mitrochenko. Thermionic RF Gun with High Duty Factor // *Proc. of the 17<sup>th</sup> Particle Accelerator Conference*, Vancouver (Canada), 1997, vol. 3, p. 2817-2819.
4. N.I.Aizatsky, E.Z.Biller, A.N.Dovbnya et. al. Two-cell RF gun for a high-brightness linac // *Proc. of the fifth European Particle Accelerator Conference*, Sitges (Barcelona), 1996, v. 2, p. 1553-1555.
5. W.B.Herrmannsfeldt. *EGUN: Electron Optics Program*, Stanford Linear Accelerator Center, SLAC-PUB-6729, 1994.