

DEVELOPMENT OF LINEAR PROTON ACCELERATORS WITH THE HIGH AVERAGE BEAM POWER

V.A. Bomko, B.V. Zajtzev, A.M. Egorov
NSC KIPT, Kharkov, Ukraine, bomko@kipt.kharkov.ua

Review of the current situation in the development of powerful linear proton accelerators carried out in many countries is given. The purpose of their creation is solving problems of safe and efficient nuclear energetics on a basis of the accelerator-reactor complex. In this case a proton beam with the energy up to 1 GeV, the average current of 30 mA is required. At the same time there is a needed in more powerful beams, for example, for production of tritium and transmutation of nuclear waste products. The creation of accelerators of such a power will be followed by the construction of linear accelerators of 1 GeV but with a more moderate beam current. They are intended for investigation of many aspects of neutron physics and neutron engineering. Problems in the creation of efficient constructions for the basic and auxiliary equipment, the reliability of the systems, and minimization of the beam losses in the process of acceleration will be solved.

PACS number: 29.17.+w

Design and construction of super-power proton linear accelerators is currently the topical line of development in the accelerator industry. Over the latest decade scientific teams in which the specialists of different branches of science and technology take part has been working successively on this problem in many countries. Here physicist, engineers and technologists, radio-engineers, specialists in the field of vacuum and cryogenics has been working. Here the achievements in the designing of the means for automatization and control, novel computational systems are focused. Specialists in economics, funds, and marketing are recruited for solving the problems on optimization of costs for the accelerating complex development and construction.

There is a number of reasons for such an interest in development of high- power linear accelerators. The chief reason lies in application of proton beams for generation of intense neutron fluxes. Presently the intense neutron generators described in [1, 2] such as IRNS (Argon, USA), MLNSCE (Los Alamos, USA), KENS (Japan), ISIS (Great Britain) are driven with proton linear accelerators. In a short time it is supposed to increase considerably the neutron generation at the meson factory in Los Alamos, on the linear proton accelerator, with the beam current of 1.2 mA and energy of 800 MeV using the entire accelerated beam for the neutron production. However, to solve the urgent scientific and practical problems, the neutron fluxes several orders higher than already obtained are required.

The most important goal of the creation of high-power linear proton accelerators is their application in the safe and efficient electronuclear energetics. The accelerator-reactor complex enables work in the sub-critical mode, and therefore, makes safe nuclear energetics possible. The reactor in the fast neutron mode enables the complete incineration of the most harmful radiotoxic long-lived products of nuclear reactions in nuclear fuel wastes such as plutonium and other transuranic elements generating with that a great amount of the additional energy.

Recently a need arises in the high-power proton beams for electronuclear energetic facility (ENEF) of different types.

1. ENEF in which the additional elucidation of the fuel arranges in neutron driven reactors is carried out with the proton beam [2, 3]. Such experimental complexes where a proton linear accelerator will be used as a driver are being created in Russia [5, 6]. In the frame of the reactor a targeting blanket system will be assembled. To create a full-scale ENEF of this type the proton beams with estimated power of 100 MW are required.

2. As an electronuclear energy installation the energy amplifier EA is used, an accelerator-reactor complex in which the reactor of a new type operates in the sub-critical mode on fast neutrons. This electronuclear system is suggested by CERN specialists and is described in the papers [7-9]. The additional elucidation is carried out with hard neutrons (to 10 MeV) generated in the spallation-reaction at the lead target irradiated with a proton beam with the energy of 1 GeV and current of 30 mA. Fuel elements are submerged into melted lead which is, at the same time, the medium for the fuel elements, a heat carrier, a neutron moderator, and a radioactive radiation absorber. A mixture of the thorium with any fission materials: transuranic elements ("dirty" plutonium), weapon plutonium, ^{235}U serves as the fuel. In the course of EA reactor operation, generation of fissile ^{233}U from thorium takes place that may be used for LWR fuel enrichment or for "seeds" of the next EA loading cycles. The EA reactor has an advantage that lies in the fact that besides the safe nuclear energy production it removes the most harmful TRU radioactive waste producing an additional energy in amount of 36% from the energy already generated at the LWR. Moreover, with the nuclear waste incineration the EA enables the transmutation on the leakage from the core neutrons of the harmful long-lived radionuclides ^{99}Tc and ^{129}I separated from the nuclear fuel. The conceptual principles of the EA have been subjected to theoretical and experimental tests.

By the time, i.e., by the middle of the second decade, proton linear accelerators meeting the demands.

The power of the proton beam necessary for the EA complex should be about 30 MW. The optimal proton beam should be accelerated to 1 GeV and have the average current of 30 mA. The project of the accelerator is submitted at the CERN [10]. Its actuality is based on the

large experience that the team from the department of accelerators possesses in development and construction of the superconducting accelerating modules and RF power supply systems in the LEP structure. Currently several European institutions joint their efforts in the frames of the CONCERT program (Combined Neutron Center for European Research and Tecnology) [11] for the creation of the intense proton linear accelerator - a generator of intense neutron fluxes.

3. The more intense proton beams are necessary for the transmutation of the long-lived radionuclides from the nuclear waste for the ecologically pure tritium production. Here the proton beams are necessary with a power considerably higher than 100 MW. Such projects are elaborated and discussed in different countries. The most advanced project is the APT project (Los Alamos, USA) [12] where it is supposed to create a proton linear accelerator with the energy of 1.7 GeV and average beam current of 100 mA. The main goal is tritium production. Funds for the construction is not transferred yet

but all the scientific and technology designs are secured the financial backing. By the present time the most important initial part of the LEDA accelerator - an injector and proton accelerator for the energy of 6 MeV and superconducting cavities for the main high-energy section of the accelerator are constructed and tested. In the meantime in the USA the financing of another large multipurpose proton accelerator for the energy of 1250 MeV (the SNS project) is confirmed [13]. It will be constructed by a joint team from Los Alamos, Oak-Ridge, Berkley, Brookhaven. It is supposed to put this accelerator into operation in 2005.

In the Table the list of linear accelerator projects under development is given [2].

Fig. 1 presents the conceptual scheme of the APT proton linear accelerator [14] being developed in Los Alamos The proton energy at the output of the every section of the accelerator, the operating frequency, the acceleration rate are shown. Its full length is 1220 m.

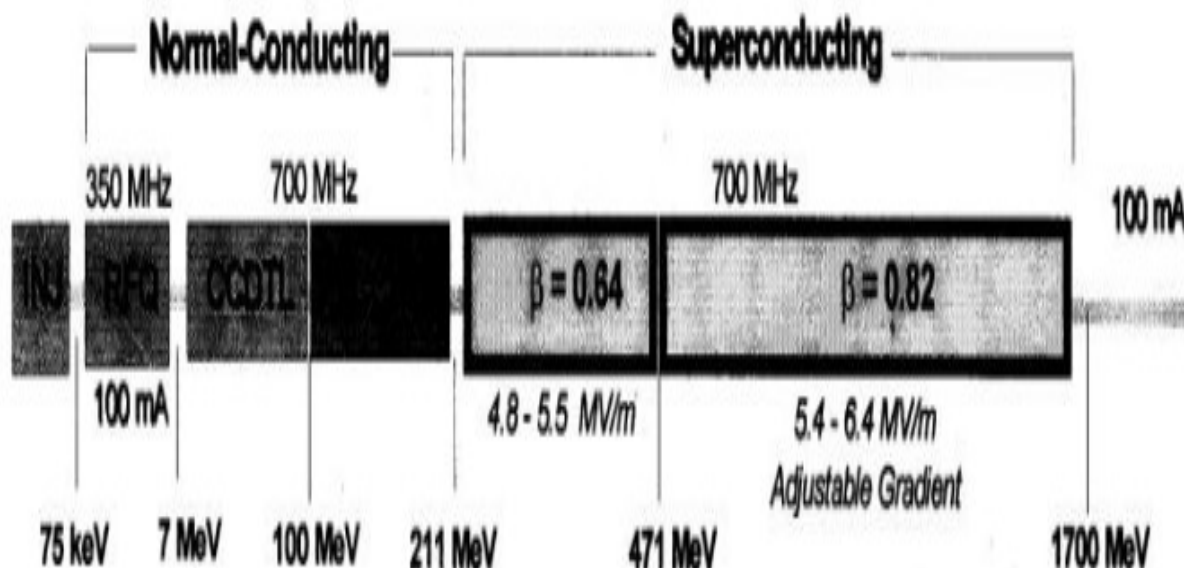

Fig. 1. The conceptual scheme of the APT proton linear accelerator.

As one can see from the Table the accelerators differ significantly in final parameters of the accelerated proton beams and in modes of operation. Nevertheless, their functions are the same - generation of the intense neutron beams in various energy ranges. In most of the projects it is assumed to use neutron beams in various investigations, but the CERN project and the joint project proposed by ITEP, MRTI, IPHE, and INR [15] are intended for operation in the ENEC complex.

At the same time, on the way to energetics of future it is necessary to solve problems both in accelerating technology and in power proton beam conversion in intense neutron fluxes, and in their application as additional elucidation in the sub-critical reactor. For these purposes less ambitious and more real accelerators at the present stage are developed. The more typical are

the KURRI projects in the Kioto university (Japan) [16] and ITEP (Russia) [2, 5, 6,]. Both installations are multipurpose and are at the high level of readiness.

Table. The projects of the power proton beam accelerators.

Project	W, MeV	I, mA	P, MW
APT, USA	1700	100	100
SNS, USA	1250	2 (4.4)	2.65 (4.4)
JAERRY, Japan	400-600	0.33 (5)	1 (5)
TRISPAL, France	600	400	24
TRASCO, Italy	1000	10-100	35
KOMAC Korea	1000	20	20
ESS Europe	1330	3.7	5

EA, CERN	1000	25-30	25-30
CNGS, CERN	2200	2	4
ITEP, INR MRTI, IPHE,	1000	30	30

A scheme of the KURRI complex is shown in Fig. 2. At the initial section D⁺ and H²⁺ will be accelerated with a pulsed beam current of 100mA. It is supposed to focus the deuteron beam on the tritium target with the energy of 400 keV to obtain neutrons with the energy of 14 MeV. In future it is supposed to produce beams of different energy: 2 MeV, 20 MeV, 100 MeV, and 300 MeV. Thus the neutron fluxes of different intensity will be generated in the wide energy range. Eventually, the proton beam accelerated to the energy of 300 MeV will be produced on the sub-critical reactor assembly.

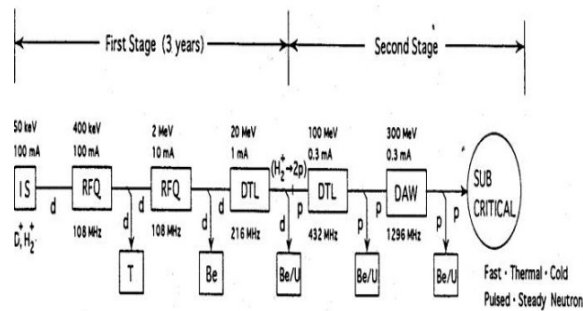

Fig. 2. A scheme of the KURRI complex.

In the context of the foregoing I would like to turn back to the events which occurred twenty years ago. Then at the KIPT the works on development of the powerful proton accelerator of the 100 MeV and average beam current of 0.5 mA were carried out. These works were completed in 1975, and a technical project [17] was developed. As it follows from the technological documents on the project, at the present time its parameters are at the modern level. That enabled a high stability of the accelerator operation with passive resonance systems, and what is especially important, one used a method of the smooth energy adjustment of the accelerated protons in the wide energy range. At the same time, there were provided as in KURRI and ITEF projects additional outputs on the target for the proton beams of the intermediate energy. Thus, this accelerator offered significant advantages for multipurpose researches in the neutron physics, reactor material technology, nuclear physics, and in a large number of applied, technological, medical and biological applications.

The average beam intensity of 50 kW and final energy of 100 MeV give a possibility to create intense epithermal and fast neutrons on the lead and beryllium targets. The total yield of neutrons from the lead target irradiated with the proton beam of 100 MeV and average current of 0.5 mA is $1.25 \cdot 10^{15}$ neutrons/s.

Due to the presence of an additional energy output on the target and the method of the smooth adjustment of the accelerated particle energy, a possibility of intermediate beam energies develops favorable conditions for neutron production in the wide energy range. In the project the margin of the accelerating field strength was supposed that enabled to accelerate the particles with a

mass-to-charge ratio of $A/q=2$ at the initial section (to 10 MeV). Thus, the accelerated deuteron beam in the deuterium-tritium reaction would give a possibility to produce neutrons with energies of 14 MeV.

For Ukraine the LUP-100 project may be the starting point for creation of future safe and efficient energetics based on electronuclear installations. The guarantee is, from one hand, highly developed nuclear- power engineering, and from other hand, the high level of nuclear physics and accelerating technology at the NSC KIPT.

REFERENCES

- Gardner. A Review of Spallation Neutron Source Accelerators // *Proc. of EPAC-98*, p. 93-97.
- N.V.Lazarev, A.M.Kozodayev, Super-powerful linear proton accelerators for neutron generators and electronuclear plants // *Atomnaya energiya*, 2000, v. 89, # 6, p. 440-454.
- Yu.M.Ado. *Sub-critical reactor with external neutron lighting*. Preprint IFEV, Protvino 93-24, 1993, 16 p.
- V.P.Dmitrievsky. *Electronuclear technique of atomic energy production*. JINR, Dubna, 1997, v. 28, p. 815.
- I.Chuvilo, M.Katz, A.Kozodaev. et al. Proton 36 MeV, 0.5 mA Linac ISTR-36 as a Driver of Multipurpose Irradiation Test Facility // *Proc. of EPAC-96*. p. 2674-2676.
- A.M.Kozodayev, R.M.Vengrov, A.A.Drozdosky. Prospects of developing the driver for the IFVE neutron rator generator // *Proc. of Intern. Conf. on Sub-Critical Accelerator Driven Systems*, ITEP, 1999, p. 258-261.
- Rubbia, J.A.Rubio, S.Buono et al. *Conceptual Design of a Fast Neutron Operated High-Power Energy Amplifier*. CERN/AT/95-44 (ET).
- C.Rubbia, S. Buono, E.Gonsales et al. *A Realistic Plutonium Elimination Scheme with Fast Energy Amplifier and Thorium-Plutonium Fuel*. CERN/AT/95-53 (ET).
- C.Rubbia. *Resonance Enhanced Neutron Captures for Element Activation and Waste Transmutation*. CERN/LHC/97-04 (EET).
- C Rubbia and J.A.Rubio. *A Tentative Program Towards a Full-Scale Energy Amplifier*. CERN/LHC/96-11 (EET).
- Haseroth. Status of Studies for a Neutrino Factory of CERN // *Proc. of EPAC-2000*, p. 253-255.
- P.Lisovsky. The APT Project. // *Proc. of PAC-97*. p. 3780-3784.
- R.Kustom. *An Overview of the SNS Project*. LINAC-2000, Report TU-101.
- J.M.Lagniel. A Review of LINAC and Beam Transport Systems for Transmutation // *Proc. of EPAC-98*, p. 93.
- O.V.Shvedov, B.P.Murin, V.A.Teplyakov et al. *High-energy proton linear accelerator – driver of electronuclear systems*. Preprint ITEP 35-99, 1999.
- Y.Kawase, S.Schiroya, M.Inoue. *An Accelerator-Assisted Nuclear Fuel AR Assembly for Future Project at KURRI*. In: APAC-98, p. 104-106.

17. V.A.Bomko, A.F.Dyachenko, A.P.Klyucharev et.al.
Linear-accelerator complex LUI-100 // *Proc. of*

5 All-Union. Conf. on Charged Particle Accelerator. Dubna, 1976, v. 1, p. 92-95.