

PACS numbers: 07.60.Dg, 61.72.up, 68.49.Sf, 78.40.Ri, 81.05.ub, 81.07.Nb, 81.15.Cd

Obtaining and Spectrophotometric Study of Organic Solutions of C₆₀ Endo- and Exometallofullerenes

B. V. Borts, V. I. Tkachenko, A. V. Moskvitin, and Yu. G. Kazarinov

*National Scientific Centre 'Kharkiv Institute of Physics and Technology',
1, Academichna Str.,
61108 Kharkiv, Ukraine*

The method of ion-implantation synthesis of endo- and exofullerenes is developed. The samples of fullerenes containing iron, platinum or their mixture are prepared. Spectrophotometric investigations of low-concentration solutions of metallofullerenes dissolved in organic solvents (toluene) are carried out. As shown, the bonding of metal atoms to the fullerene leads to the broadening of the absorption-spectrum line width and to the absorption-maximum shift to the long-wave part of the spectrum. The half-width and the shift are increasing in the series of C₆₀-C₆₀ + Pt-C₆₀ + Fe-C₆₀ + Fe + Pt.

Розроблено методику синтези ендо- та екзофуллеренів методом йонної імплантації. У цей спосіб було створено зразки фуллеренів, що містять залізо, платину або їхню суміш. Виконані спектрофотометричні дослідження розчинів металофуллеренів малої концентрації в органічних розчинниках (толуолі) показали, що зв'язок атомів металу із фуллереном спричиняє розширення смуг у спектрах оптичного вбирання та зсув максимумів цих смуг у бік довгих хвиль. Півширина смуги та величина зсуву збільшується у ряду C₆₀-C₆₀ + Pt-C₆₀ + Fe-C₆₀ + Fe + Pt.

Разработана методика получения эндо- и экзофуллеренов методом ионной имплантации. Проведены спектрофотометрические исследования растворов малых концентраций полученных металлофуллеренов в органических растворителях. Показано, что присоединение к фуллерену атома металла приводит к увеличению ширины линий в спектре поглощения и смещению максимума поглощения в длинноволновую часть спектра. При этом полуширина и смещение увеличиваются в ряду C₆₀-C₆₀ + Pt-C₆₀ + Fe-C₆₀ + Fe + Pt.

Key words: fullerenes, C₆₀-C₆₀ + Pt-C₆₀ + Fe-C₆₀ + Fe + Pt, implantation synthesis, absorption spectrum.

(Received November 25, 2009)

1. INTRODUCTION

One of unique properties of fullerene molecules is an ability to contain trapped atoms and molecules of other elements within their carbon cage. The state of atomic particles, entrapped within the fullerene shell, is peculiar and cannot be reproduced in a different way. Our interest concerns endohedral and exohedral fullerenes containing, inside or outside, atoms of other metals. Compounds of fullerenes with atoms of inert gases and nitrogen attract lesser attention than metallofullerenes, as the interaction between the endohedral atoms and the carbon cage is weak and compounds obtained do not possess new specific properties.

Interest in fabrication of a wide range of endo- and exohedral metallofullerenes [1–5] is aroused by particular properties of such-type elements, namely:

- feature of the electronic structure of endometallofullerenes related with the transfer of metal valence electrons to the fullerene shell;
- endofullerenes containing atoms of the second-group metals possess diamagnetic properties, since the entrapped two-charge metal ion contains only fully occupied electron shells, and the spin moments of valence electrons being on the external orbitals of the fullerene shell are completely compensated;
- endofullerenes containing atoms of the third-group metals possess paramagnetic properties since the entrapped three-charged metal ion transfers three electrons onto the fullerene shell;
- displacement of a metal atom relatively to the geometric centre of the molecule is related with transfer of valence electrons from the entrapped atom onto the outer surface of the fullerene shell;
- displacement of the equilibrium position of the entrapped atom causes the presence of a rather significant constant dipole moment in such molecule and the constant polarizability occurrence;
- presence of electrons on the external surface of the fullerene shell determines the character of intermolecular interactions in the crystal, which receives contributions from the Van der Waals mechanism and from the covalent one;
- endofullerenes show ability to the orientation arrangement that gives anisotropic properties to the fullerene-based crystals, making them a promising material in for various applications.

At present, the opportunity to apply endohedral structures directly in the technology and technique of physical experiment is rather limited, first, because of extremely high cost of their production [6].

The method of ion implantation synthesis of endohedral fullerenes is based on the bombardment of empty fullerenes with ions of the element that should be implanted into the carbon cage of a fullerene molecule or are bonding with the outside of the cage by the electron couplings. However, to obtain accelerated metal ions, it is necessary to create an ion source capable to produce ions, desirably all ions from the Periodic Ta-

ble, which is a very difficult problem. The second problem is that for all ion sources, as a rule, a beam mass separator is required, and the energy obtained at the ion injector output is in the range of 20–30 keV. With such energy, the incoming metal ion will break down electron couplings, knockout carbon atoms from the lattice and will not establish necessary fullerene couplings. The energy necessary for production of endo- and exofullerenes is in the range of 10–100 eV. For intercalation of metal atom, the energy should be selected so that the metal atom can approach to the fullerene molecule. Then, this atom will bond with the carbon atom outside the cage and establish the electron couplings with it, or will open one of the electron couplings and penetrate into the carbon cage, and the disturbed coupling will be re-established after that.

2. FABRICATION OF METALLOFULLERENES

On the assumption of the above-mentioned conditions, we have developed an installation (Fig. 1) capable to perform the fullerene intercalation using any metal atoms. To obtain a flux of metal atoms, we use an ion source producing an ion beam from the inert gases (argon or xenon) with energies from 10 to 30 keV and a current to 100 μ A. The beam is directed at an angle from 0° to 85° onto the metal support and, as a result of its sputtering, the flux of metal atoms with energies from 10 to 100 eV is formed there.

Under the action of inert gases with energies from 10 to 30 keV, the diffused atoms have a wide energy distribution on the metal target surface with a maximum near the low values of kinetic energy (Fig. 2) [7].

Irradiating the metals under different angles, it is possible to separate the maxima of angle distribution of high-energy reflected particles of inert gas and the diffused particles of the target with energies sufficient for metal ion implantation into the fullerene molecule (Fig. 3) [8].

In connection with a low probability for the output of sputtered parti-

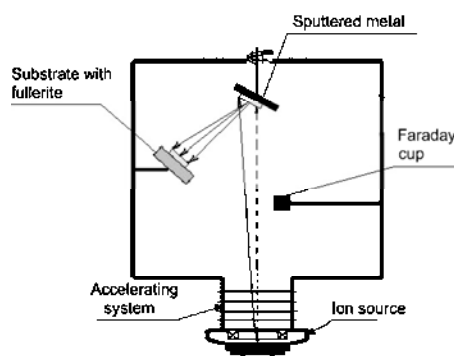

Fig. 1. Installation for metal-ion sputtering onto the fullerite.

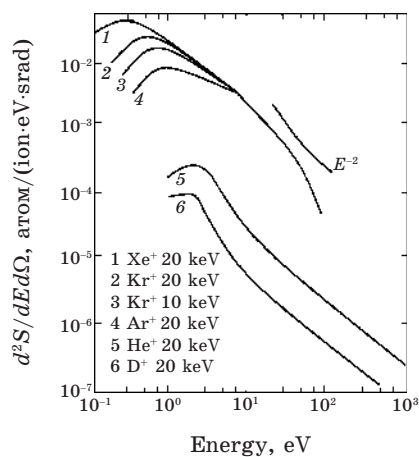

Fig. 2. Energy distribution of sputtered atoms from the crystalline gold target by different ions.

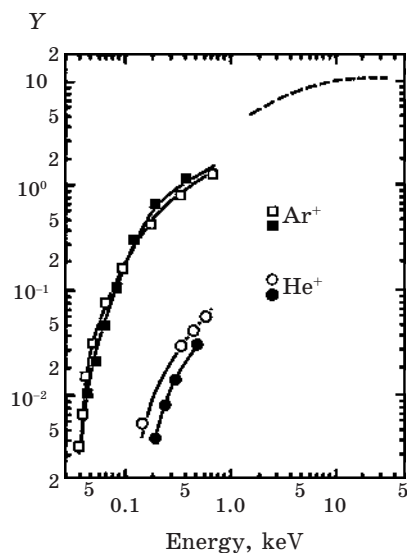

Fig. 3. Experimental values of Pt sputtering yield.

cles with energies sufficient to break up fullerenes, the given method can be used for effective production of endo- and exofullerene compounds.

The machine was used for intercalation fullerenes with iron (99.99% purity) or platinum atoms as well as with iron and platinum together. Fullerenes were extracted from the soot synthesized in the helium medium by the vacuum arc method. The values of pressure (100–200 Torr) and arc current (60–70 A) were determined by the optimum yield of

fullerenes. Extraction of fullerenes from the soot was performed with the use of a laboratory facility comprising a standard Soxhlet's apparatus and rotary evaporator modified by the vacuum pumping. The latter decreases significantly the temperature of boiling solvent.

The fullerene compound was separated by the method of liquid-solid adsorption chromatography in the chromatographic column filled with graphite or Al₂O₃. The column has a valve controlling the eluent inflow rate. Toluene or toluene mixed with hexane was used as an eluent. The synthesized fullerene crystals were put on the watch crystal for treatment with metal atoms or were dissolved in the little amount of toluene and then were dried on the watch crystal in the drying chamber.

3. SPECTROPHOTOMETRIC STUDY OF ORGANIC SOLUTIONS OF C₆₀ ENDO- AND EXOMETALFULLERENES

The spectrophotometric method [9] can be applied for identification of metallofullerenes prepared. This method provides much information about the interaction between modified fullerenes and solvent molecules [10, 11]. A metal atom implanted inside or bonded outside of the fullerene molecule forms couplings with carbon atoms and substantially changes the electronic and other properties of the molecule that influences on the position and width of bands in the molecule absorption spectrum. Purification (separation) of metallofullerenes was not specially carried out, therefore C₆₀ endo- and exometallofullerenes, slightly changing the absorption spectra, made an insignificant part in the total number of fullerenes. However, these changes can be observed by the method of optical spectrometry of diluted organic solutions of metallofullerenes.

Earlier, we have studied the optical spectra of organic solutions of pure fullerenes synthesized in laboratory using the vacuum-arc installation [2]. Similar samples of pure fullerenes C₆₀ were used as a target for irradiation with atoms and ions of sputtered metals. The absorption spectra of pure fullerenes were standards in the spectrophotometric investigations of organic solutions of C₆₀ endo- and exometallofullerenes, prepared in the present work.

The spectrophotometric methods are the most advanced in technological studies for which the rapidity, low cost of measurements, and little amounts of the material investigated are important factors.

Comparison between the absorption spectra of thin (10–100 μm) fullerene films formed in vacuum [13] and the absorption spectra of highly diluted (10–100 μg/ml) fullerene solutions demonstrates a similar behaviour of absorption spectra in the range of 180–600 nm. Such thin fullerene films should be investigated in the inert medium, as in the oxygen-containing atmosphere fullerenes are oxidized to exohedral forms. Highly-diluted fullerene solutions (of 10–100 μg/ml) allow stable working in the oxygen-containing atmosphere as the solvent pro-

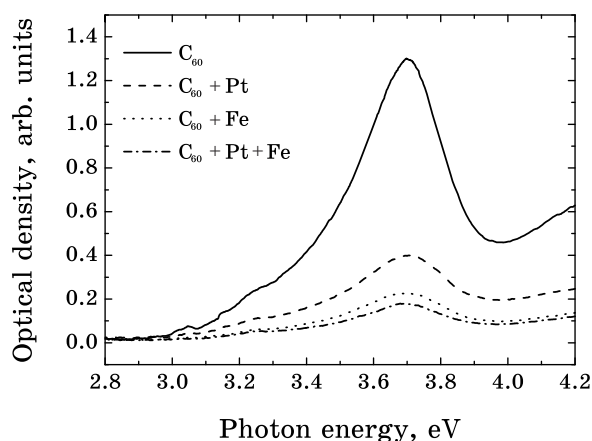

Fig. 4. Absorption spectra of metallofullerenes and C_{60} .

TABLE 1. Initial concentrations of the fullerene solutions investigated.

Sample	Concentration of an undiluted sample, mg/ml	Accuracy, %
C_{60}	0.44	4.7
$C_{60} + Pt$	0.16	4.6
$C_{60} + Fe$	1.15	1.9
$C_{60} + Pt + Fe$	0.71	2.9

protects fullerenes from the interaction with oxygen and other gases. The fact that the absorption spectra of fullerenes and diluted fullerene solutions are identical can give nontrivial theoretical interpretations and should be considered separately.

In a given work, we have carried out measurements of the absorption spectra of solutions of fullerenes C_{60} , $C_{60} + Fe$, $C_{60} + Pt$, and $C_{60} + Fe + Pt$ by means of a SF-2000 spectrometer in toluene at room temperature. The initial solutions (of concentrations presented in Table 1) were diluted with toluene to obtain the optical solution density of an order of unit.

Figure 4 presents the absorption spectra of metallofullerenes and pure fullerenes C_{60} . Comparison of the absorption spectra obtained for different metals proves, despite the difference between the atomic mass and the charge of trapped atoms, the validity of an empiric rule that absorption spectra of toluene solutions of different $C_{60} + Me$ are identical [13].

Figure 5 shows an enlarged image of the spectral region near the peak of 335 nm (3.7 eV) after normalization and smoothing. As seen, because of fullerene treatment with metal ions, the peak position of the optical density and the width of maximum are varying.

The metal influence on the optical spectra of fullerenes was studied by decomposition of normalized spectra into the components in the form of Gaussian profiles.

Detailed analysis has shown that the peak form is insignificantly changing under iron ion action (Fig. 6, *a*), while heavier platinum ions

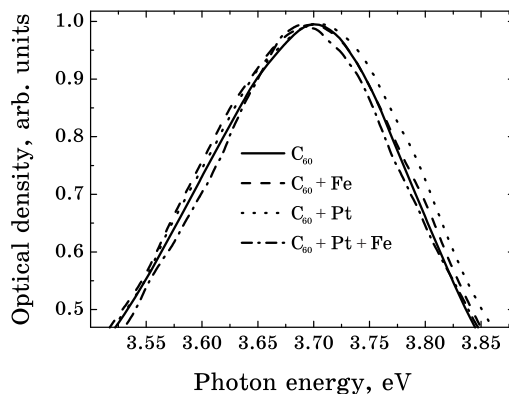

Fig. 5. Region near the peak of absorption spectra of metallofullerenes and C_{60} after normalization and smoothing.

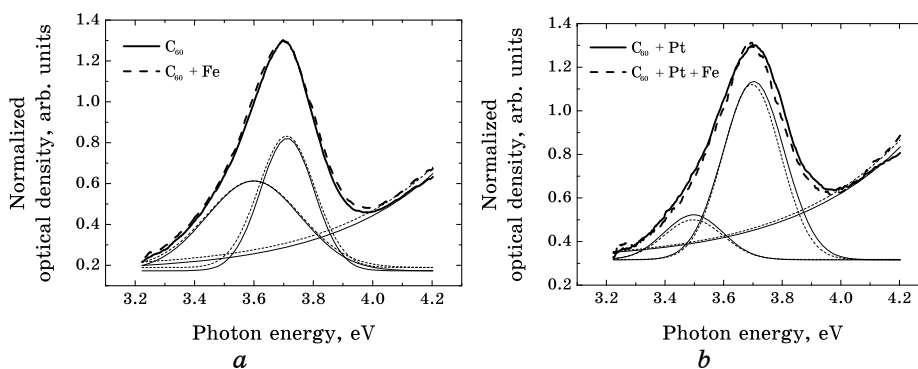

Fig. 6. Absorption spectra of fullerenes (thick lines) and C_{60} decomposed into components (thin lines).

TABLE 2. Peak energy and width of fullerene solutions under consideration.

Sample	Energy, eV	FWHM, eV
C_{60}	3.712	0.213
$C_{60} + Pt$	3.710	0.223
$C_{60} + Fe$	3.696	0.231
$C_{60} + Pt + Fe$	3.702	0.246

lead to the peak deformation (Fig. 6, *b*). Parameters of the main peak are given in Table 2 in the order of full width broadening at half-maximum (FWHM) of peak.

The influence of platinum on the optical properties of fullerenes is less as compared to iron and has an effect, for the most part, on the main peak width, while the peak of iron-containing fullerenes is more shifted.

4. CONCLUSIONS

The method of ion implantation synthesis of endo- and exofullerenes was developed. The samples of fullerenes containing iron, platinum, or their mixture were prepared. Spectrophotometric investigations of low-concentration solutions of fullerenes dissolved in organic solvents (toluene) were carried out. As demonstrated, the bonding of a metal atom to the fullerene leads to the broadening of the absorption-spectrum line-width and to the absorption-maximum shift to the long-wave part of the spectrum. The half-width and the shift are increasing in the series of C_{60} - C_{60} + Pt- C_{60} + Fe- C_{60} + Fe + Pt.

REFERENCES

1. L. N. Sidorov and I. N. Ioffe, *SOJ*, **7**, No. 8: 30 (2001) (in Russian).
2. A. V. Elets'kiy and B. M. Smirnov, *Uspekhi Fiz. Nauk*, **161**, No. 7: 173 (1991) (in Russian).
3. A. V. Elets'kiy and B. M. Smirnov, *Uspekhi Fiz. Nauk*, **163**, No. 2: 33 (1993) (in Russian).
4. V. N. Bezmelnitsyn, A. V. Elets'kii, and M. V. Okun, *Uspekhi Fiz. Nauk*, **168**, No. 11: 1195 (1998) (in Russian).
5. B. M. Ginzburg, Sh. Tujchiev, and S. H. Tabarov, *Pis'ma v ZhTF*, **33**, No. 15: 22 (2007) (in Russian).
6. T. L. Makarova, *Fizika i Tekhnika Poluprovodnikov*, **38**, No. 6: 641 (2004) (in Russian).
7. R. Berish, *Sputtering by Particle Bombardment* (Berlin: Springer: 1981).
8. *Fundamental'nyye i Prikladnyye Aspekty Raspilyeniya Tvyordykh Tel* (Fundamental and Applied Aspects of Sputtering of Solids) (Ed. E. S. Mashkova) (Moscow: Mir: 1989) (in Russian).
9. A. V. Elets'kiy, *Uspekhi Fiz. Nauk*, **170**, No. 2: 113 (2000) (in Russian).
10. G. N. Churilov, N. V. Bulina, and A. S. Fedorov *Fullereny: Sintez i Teoriya Obrazovaniya* (Fullerenes: Synthesis and Theory of Formation) (Novosibirsk: Publishing House S.O.R.A.S.: 2007) (in Russian).
11. D. V. Shchur, Z. A. Matysina, S. Yu. Zaginaichenko, *Uglerodnyye Nanostruktury i Fazovyye Prevrashcheniya v Nikh* (Carbon Nanostructures and Their Phase Transformations) (Dnepropetrovsk: Nauka i Obrazovanie: 2007) (in Russian).
12. I. M. Neklyudov, B. V. Borts et al., *Collected Transactions of Heat and Mass Transfer Institute of N.A.S. of Belarus* (Ed. P. A. Vityaz) (Minsk: Publ. Centre B.S.U.: 2008) (in Russian).
13. H. Shinohara, *Rep. Prog. Phys.*, **63**: 843 (2000).