

V.P. Kyselov

Institute of Bioorganic Chemistry & Petrochemistry of National Academy of Ukraine, Kyiv

## MEMBRANELESS FUEL CELLS TO OBTAIN ELECTRIC POWER OF DIRECT & ALTERNATING CURRENT FROM CHEMICAL REACTIONS & BIOPROCESSES



Patents № 86811, № 86812 25.05.2009

The method and apparatus for direct obtaining of electric power from the energy of fuel oxidation reaction in a stream of oxidizer are well-known, the core principle of this method is creation of conditions for oxidizing fuel by oxidizer in order to generate a flow of positive and negative charges, and for their subsequent separation and parting onto anode and cathode using one-way ion-exchange membranes.

Connection of electrodes to an external electric circuit provides generation of direct electric current.

The disadvantage of this method is that separation of positive and negative charges is effected by using ion-exchange membranes. They are the most expensive elements in the construction of a fuel cell, as well as very fragile (short-lived). Moreover, the physics of these elements is not studied enough so far, which leads to technological complexity and hinders a widespread industrial use of fuel cells. Another disadvantage of this method is the impossibility of changing the direction of electric current in the external circuit, which results in inability to create a source of alternating current.

We have improved the well-known method and device, which allowed us to produce electric

energy of direct or alternating current. To achieve this goal: *a*) we removed a one-sided conductive membrane; *б*) we installed a magnetic or electric field into the cell, which resulted in separation of positively and negatively charged particles onto the anode and cathode of the cell under the influence of forces generated by the motion of charges in these fields.

The principle of the proposed electrochemical generator remains the same. The reaction of fuel and oxidizer generates a flow of anions and cations which migrate to the anode and cathode un-

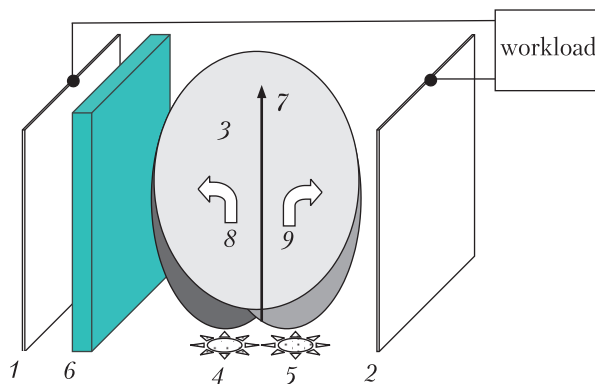
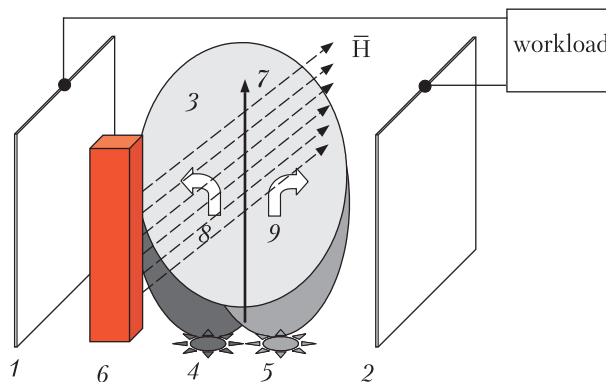

**Fig. 1.** Illustrates the operation & functions of the prototype elements: 1 – anode, 2 – cathode, 3 – area of reaction, 4 – fuel feeder, 5 – oxidizer feeder, 6 – ion-exchange membrane. Arrow 7 indicates the initial direction of movement of fuel, oxidizer and reaction products, and arrows 8 and 9 – the directions of charges deviation

der the influence of an external magnetic or electric field. In this case:

- ✦ there is no need to use ion-exchange membranes;
- ✦ the efficiency of charge separation increases since additionally imposed electric or magnetic field affects both positive and negative charges, changing their movement in opposite directions.
- ✦ it is possible to change the direction of deviation of charged particles in real time by replacing a static magnetic or electric field to a variable one and getting alternating electric current in the external circuit.

The main feature of the proposed solution is that it does not violate the previously known principles of construction of fuel cells, except that of separation of charges. The principle of division of generators into three types depending on operating temperature remains the same. The properties acquired by fuel cells with introducing into their design catalysts of various processes remain unchanged. Different methods of cells commutation are possible. The proposed

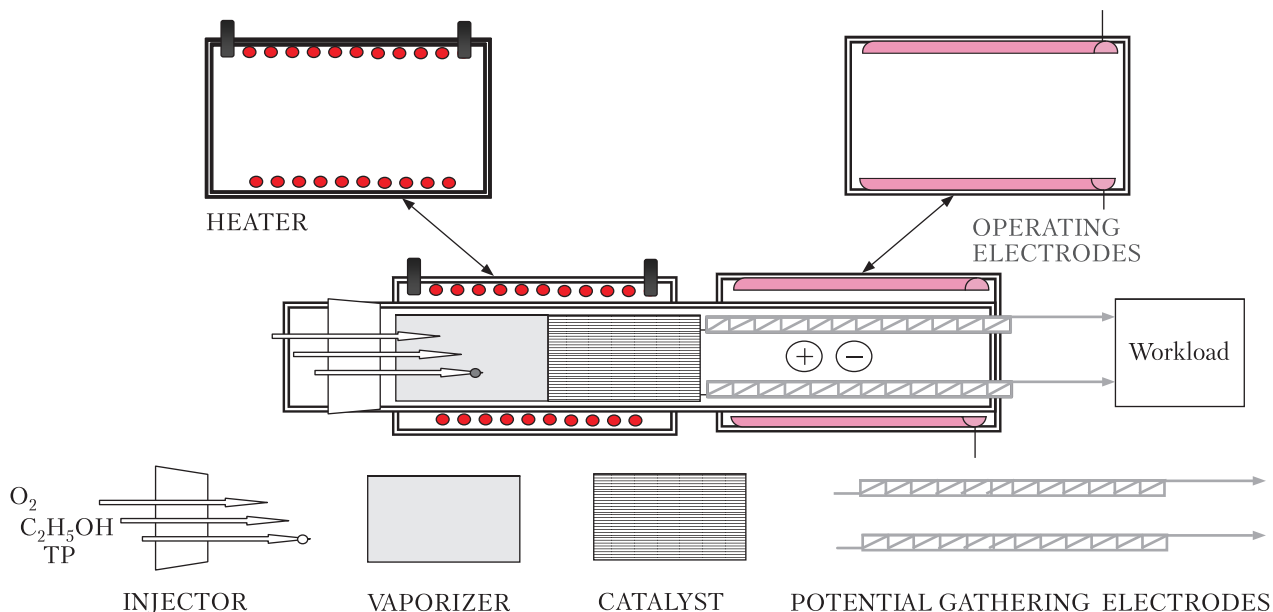

**Fig. 2.** Illustrates the operation & functions of elements of the proposed fuel cell of magnetic type; where: 1 – anode, 2 – cathode, 3 – area of reaction, 4 – fuel feeder, 5 – oxidizer feeder, 6 – source of magnetic field. Arrow 7 indicates the initial direction of movement of fuel, oxidizer and reaction products, and arrows 8 and 9 – the directions of charges deviation

method of separation is applicable for all types of fuels, in all electrolytes, etc.

### The Results of Laboratory Investigations

Prototype of a membraneless fuel cell (fuel – ethyl alcohol; oxidant – atmospheric oxygen).



**Fig. 3.** structure, function of elements and principle of operating of membraneless fuel cell of electric type

Operating Principle:

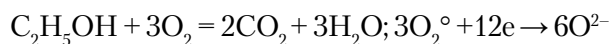

Operating Mode – a low temperature one (up to 60 °C).

$$U_{out.} = 1,2V, I_{sc} = 0,450 \mu A.$$

Cell size  $\Phi = 8mm; L = 100mm$

*Prototype of a membraneless biofuel cell  
(electric biocell; biocell)*

Electrolyte – Microorganisms of E. coli 2163 strain in LB medium per 1 L: trypton – 10 g; yeast extract – 5 g; NaCl – 10 g;  $pH = 7.0$ .

Temperature – 20 °C

$$U_{output} = 175mV, I_{sc} = 5 mA$$

Cell size  $S = (10 \times 10 \times 10) mm$ .

---

**ЕВРОПЕЙСКИЙ СОЮЗ  
ГОТОВ ПРЕДОСТАВИТЬ  
УКРАИНЕ ДЕНЬГИ  
НА ПРОГРАММУ  
ЭНЕРГОСБЕРЕЖЕНИЯ**

30 декабря 2010 года представитель делегации Европейского Союза в Украине Ганс Райн передал председателю Национального агентства Украины по вопросам обеспечения эффективного использования энергетических ресурсов (НАЭР) *Николаю Пашкевичу* предварительный отчет консультантов группы «Кови» относительно программы «Бюджетная поддержка», согласно которой Европейская делегация готова предоставить Украине грант в размере 63 млн. евро на программу энергосбережения и 7 млн. евро на техническую помощь.



В ходе встречи председателя НАЭР с представителями делегации Европейского Союза в Украине и группы Всемирного Банка одним из главных стал также вопрос влияния проводимой в Украине административной реформы на дальнейшее развитие НАЭР. Пашкевич отметил, что в связи с реорганизацией НАЭР будет ликвидирована Государственная инспекция по энергосбережению. Ее основные функции, такие, как мониторинг энергоэффективных проектов, исследование рынка услуг и товаров в сфере энергоэффективности, снижение энергоемкости товаров и услуг, в первую очередь монопольного производства, популяризация внедрения энергоэффективных технологий и возобновляемых источников энергии будут переданы представителям НАЭР в регионах, которые будут созданы в ближайшее время. «Вместе с тем реорганизация будет способствовать усилению функций Агентства в направлении использования возобновляемых источников энергии», — отметил Пашкевич.

*По материалам: РБК-Украина*