

UDC 621.9.01

**K. Sobiyl\*, I. Sigalas**

School of Chemical and Metallurgical Engineering University  
of the Witwatersrand

\*kk\_sob@yahoo.com

### **High-speed machining of martensitic stainless steel using PcBN**

*The performance of PcBN cutting tool during its application in the mass production of components made from AISI 440B stainless steel has been considered. The experimental tests have been performed at cutting speed ranging between 350–500 m/min at dry cutting conditions. The machining operations that have been explored included facing, turning, grooving and boring and the 3D topography of the machined surface presented. The results show that good surface finish similar to grinding and dimensional accuracy can be achieved with PcBN tools.*

**Keywords:** *stainless steel, PcBN, surface finish, machining.*

#### **INTRODUCTION**

In the manufacturing industry, components with high surface finish and dimensional precision are often required. In ensuring reliability and functionality during the lifetime of these parts, the surfaces are generally hardened.

The hard turning process has been employed in the manufacturing industry as an alternative to grinding for producing parts from hardened steel, where manufacturing cost can be reduced up to 30 % [1]. This process can help to obtain good surface finish and dimensional and form tolerance [2].

Traditionally, carbide tools are mostly favoured in the machine shop owing to the low cost of inserts in comparison to some other tools [3, 4]. But these tools are limited when it comes to abrasive wear resistance, high tolerance and surface finish, thus, the work material is further subjected to finish grinding [5].

PcBN and ceramics are now becoming popular for mass production manufacturing of hardened materials due to their high hardness, wear resistance and good thermal shock resistance [3, 6–8].

In mass production of simple and complex components, the following factors were identified as essential for good productivity and success in metal cutting: workpiece set-up, proper selection of cutting tools, effective coolants, machining condition optimizations (cutting speeds, feed, and depth of cut), and tool changing sequences [9].

Many studies have been carried out to explore different facets of hard turning of hardened steels using the PcBN cutting tool in relationship to the tool wear, surface finish, and dimensional accuracy [6, 7, 10–14].

Due to the promising results of the low content cBN cutting tool, this study examines the application of PcBN for the mass production of complex parts. For the purpose of industrial practice and comparison of the machining method, PcBN cutting tool performance was investigated as a finishing step during turning of hardened martensitic stainless steel.

## EXPERIMENTAL

Hard turning tests were performed on hardened martensitic AISI 440 B stainless steel with chemical composition as given in Table 1. The forged shape before machining and after machining is given in Fig. 1. The work material was forged close to the final dimensions, thus only a small volume of material needed to be removed by the turning process. The material was heat treated by quenching and tempering to achieve an average hardness between 42 and 44 HRC. Machining trials were performed using a Hitachi Seiki Hitec Turn 23R III CNC lathe. Three different turning operations were selected for the machining of the part, the outer diameter (OD) turning, boring and grooving. To ensure good rigidity of the workpiece during machining, a clamping system was specially prepared by machining it to the shape of the workpiece, with small clearance to allow the workpiece to be easily inserted and removed.



Fig. 1. Component before (a) and after (b) machining.

**Table 1. Chemical composition of the AISI 440 B stainless steel**

Composition, wt %						
C	Cr	Mo	V	Si	Mn	Fe
0.9	17.5	1.10	0.10	0.45	0.40	Balance

Inserts with three different shapes were used for the turning test. The inserts tool geometry and tool holders for roughing and finishing operations are given in Table 2. Rough turning was performed on the workpiece in the presence of coolant using an uncoated tungsten carbide cutting tool (IC 9250). The finishing was performed in dry cutting conditions using SECO cBN-10 cutting tool (tipped inserts) containing 50 % cBN. Three machining operations were performed; outer diameter (OD) turning, facing boring, and grooving. All the inserts and tool holders were mounted in the turret before the commencement of the machining process so that it could be completed in a single cycle.

**Table 2. Insert geometry and tool holder with designated ISO code**

Operations	Insert geometry	Tool holder
Boring	WNGA 080408S	A25R PWLNR08
Facing and OD turning	WNGA 080408S	PWLNR 2020 KO8
Grooving (External)	LCMF 160304-0300E-LF	CFIR 2020 K03
Grooving (Internal)	LCGN 130304.0300S-LF	A20R-CGFR 1303

The machining process was performed at high speed, with the assumption that the parts would be mass produced. The machining conditions for roughing and finishing are given in Table 3. The depth of cut was kept constant at 0.3 mm. The sequence of the machining was facing, followed by OD turning, then boring and lastly grooving. The machining operations were repeated for the production of ten identical parts.

**Table 3. Machining conditions**

	Roughing				Finishing			
	Facing	OD turning	Boring	Grooving	Facing	OD turning	Boring	Grooving
Speed, m/min	150	150	200	300	350	350	500	400
Feed, mm/rev	0.35	0.35	0.15	0.1	0.1	0.1	0.1	0.1

After the end of the turning test, part surface finish was measured in the 2D and 3D arrangements with two diamond stylus contact profilometers. In addition, the three-dimensional topographic maps of the machined surfaces were produced using scanning technique. A set of the 2D roughness parameters was determined by simple roughness measurements using a shop floor T8000 (Hommel Tester) instrument using probe TKU 300. Moreover, 3D measurements were carried out on the scanned area of 10×0.5 mm (OD) and 1.5×0.5 mm (groove) by means of the profilometer. The optical 3D image of the OD was taken using an Olympus LEXT OLS410 3D laser measuring microscope.

### RESULTS AND DISCUSSION

The surface roughness of the machined parts was measured in areas as indicated in Fig. 2 with an average of five different points recorded. The average surface finish  $R_a$  of the outer diameter was 0.545  $\mu\text{m}$  and of the groove of the part 0.37  $\mu\text{m}$ . The lower  $R_a$  recorded is due to the tool feed direction used in the machining process during boring; this resulted to about 32 % reduction of the surface roughness. This surface roughness corresponds to the N6 and N5; ISO 1302:1992 code [ISO CODE], which is applicable for bearing surfaces produced by grinding.

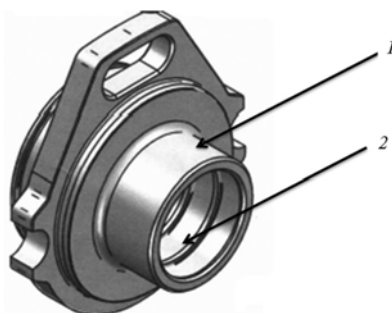

Fig. 2. Points on machined components indicating areas where the surface roughnesses were measured: 1 – OD; 2 – groove.

An example of the 2D profiles and 3D topographies of the surfaces OD and groove are presented in Figs. 3 and 4, respectively. The measured 2D parameters are given in Table 4. The ratio of  $R_t$  to  $R_z$  for the OD and groove of the machined components were about 1.466 and 1.083, respectively. The surface roughness peak height parameter  $R_p$ , showed a correlation with the maximum contact deformations, which are normally obtained during machining of rough surfaces. Thus, the ratio  $R_p/R_t$  and  $R_v/R_t$  relates the surface profile resistance to abrasive wear and deformation between the contacting surfaces [15].

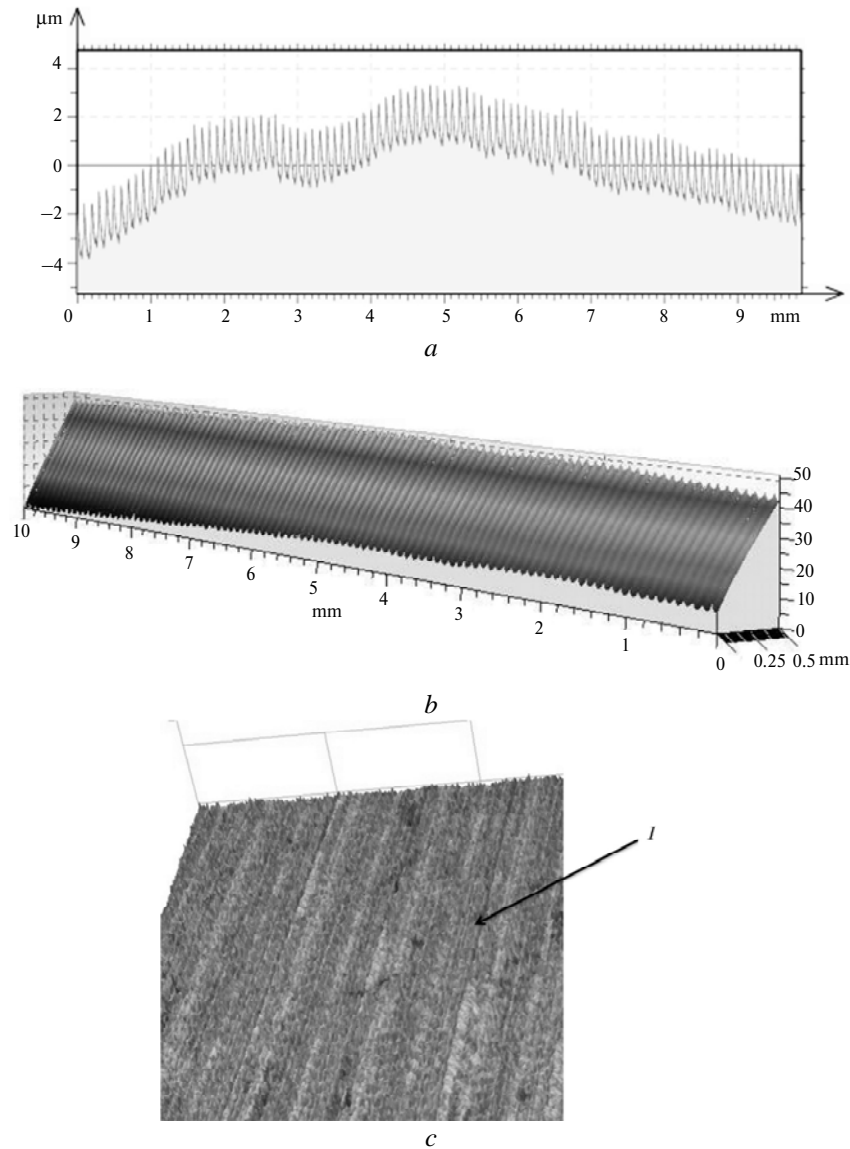

Fig. 3. 2D profiles, length = 9.87 mm,  $R_t = 7.18 \mu\text{m}$ , scale =  $10.0 \mu\text{m}$  (a) and 3D topographies (b) of OD surface: I – 3D optical image (c).

This result shows that a good surface finish can be produced using the cBN cutting tool under industrial machining conditions. The hard turning operations with cBN can be used for substituting traditional machining operations that involve a grinding proc-

ess after the turning operation, in support of Grzesik [8]. Consequently, the roughness falls within the high precision hard turning limits as indicated by Bryne et al. [6].

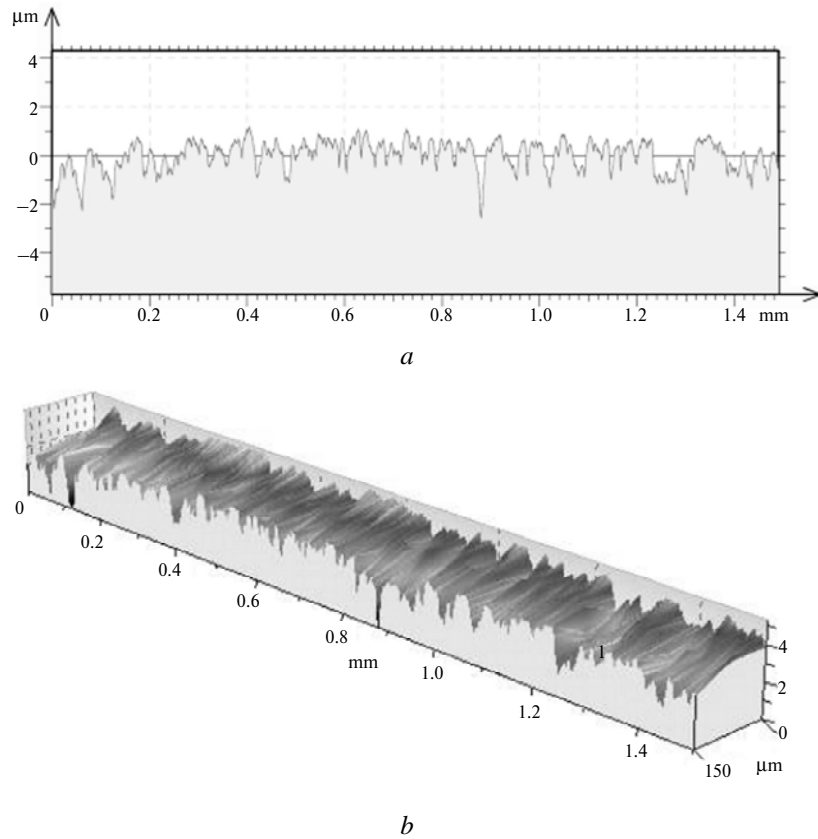

Fig. 4. 2D profiles, length = 1.49 mm,  $R_t = 3.69 \mu\text{m}$ , scale =  $10.0 \mu\text{m}$  (a) and 3D topographies (b) of the groove.

**Table 4. 2D Parameters of the OD and groove surfaces**

Parameters	OD surface, $\mu\text{m}$	Groove surface, $\mu\text{m}$
$R_t$	3.49	2.73
$R_z$	2.38	2.52
$R_p$	0.838	1.54
$R_v$	1.55	0.975
$R_a$	0.545	0.370
$R_q$	0.644	0.472

The dimensional and geometrical accuracy of some selected areas of the machined component were measured after machining ten identical parts, to observe deviation of the actual machined values from the dimensional requirements stipulated in the component design. The dimensional deviation of the measured selected parts of the component in relationship to the length, diameter and concentricity are given in Table 5. The concentricity shows the maximum deviation of about  $1 \mu\text{m}$  from the required deviation, the deviation in the straightness or length was between

14 and 18  $\mu\text{m}$ , and the geometric deviation was between 0.135 and 0.21  $\mu\text{m}$ . The results obtained were similar to the findings by Abrao et al. [14], confirming an achievable and acceptable tolerance range of IT5 within the machine tool shop during mass production of similar components.

**Table 5. Dimensional deviation from specified**

Characteristics	Size, mm	Error, mm
Length	31.75 $\pm$ 0.1	0.018
Diameter	52 $\pm$ 0.05	0.014
Length	11 $\pm$ 0.05	0.0135
Concentricity	0.005 A''	0.001
Diameter	45.1 $\pm$ 0.03	0.016
Diameter	41.6 $\pm$ 0.05	0.0206

The tight tolerance is a result of the high stiffness and accuracy of the CNC machine coupled with the excellent properties of the cBN cutting tool, such as high abrasion and thermal shock resistance [6, 16].

### CONCLUSION

The overall surface finish and dimensional accuracy generated during the application of PcBN tool for machining the specified shape shows a component acceptable tolerance range (IT5) with good surface finish (between N5 and N6) similar to that achieved with grinding operation.

The authors thank the CME precisions (Pty) Ltd. for the use of their facilities to carry out the work. We thank Patrick Johnson for his assistance during the machining trials.

This work was funded by CoE-SM and Castco precisions (Pty) Ltd.

*Розглянуто робочі характеристики ріжучого інструменту, оснащеного полікристалічним кубічним нітридом бору (КНБ), що використовують в масовому виробництві виробів з нержавіючої сталі AISI 440В. Експериментальні випробування проводили при швидкості різання в діапазоні від 350 до 500 м/хв в умовах сухого різання. Представлено операції обробки, що включають обточування торця, точіння, прорізання канавок і свердління, а також 3D-топографія обробленої поверхні. Результати показують, що, застосовуючи в інструментах полікристалічний КНБ, можна досягти хорошої якості обробки поверхні і точності розмірів, таких же як при шліфуванні.*

**Ключові слова:** нержавіюча сталь, PcBN, чистова обробка поверхні, обробка.

*Рассмотрены рабочие характеристики режущего инструмента, оснащенного поликристаллическим кубическим нитридом бора (КНБ), используемого в массовом производстве изделий из нержавеющей стали AISI 440В. Экспериментальные испытания проводили при скорости резания в диапазоне от 350 до 500 м/мин в условиях сухого резания. Представлены операции обработки, включающие обточку торца, точение, прорезание канавок и сверление, а также 3D-топография обработанной поверхности. Результаты показывают, что, применяя в инструментах поликристаллический КНБ, можно достичь хорошего качества обработки поверхности и точности размеров, таких же как при шлифовании.*

**Ключевые слова:** нержавеющая сталь, PcBN, чистовая обработка поверхности, обработка.

1. *Shihab S. K., Khan Z. A., Mohammad A., Siddiquee A. N.* A review of turning of hard steels used in bearing and automotive applications // *Prod. Manuf. Res.* – 2014. – **2**, N 1. – P. 24–49.
2. *Ursolino D. J., Oliveira A. J., Diniz A. E., Marques D. C.* Hard turning of interrupted surfaces using PcBN and ceramic tools // *Proc. of COBEM 2007, 19th Int. Cong. of Mech. Eng., Brasilia DF, 5–9 Nov., 2007.*
3. *Sales W. F., Costa L. A., Santos S. C. et al.* Performance of coated cemented carbide, mixed-ceramic and PCBN-H tools when turning W320 steel // *Int. J. Adv. Manuf. Technol.* – 2009. – **41**. – P. 660–669.
4. *Noordin M. Y., Kurniawan D., Tang Y. C., Muniswaran K.* Feasibility of mild hard turning of stainless steel using coated carbide tool // *Ibid.* – 2012. – **60**. – P. 853–863.
5. *Grzesik W.* Machining of hard materials, in *Machining fundamentals and advances* / Ed. P. Davim. – London: Springer, 2008. – P. 97–126.
6. *Byrne G., Dornfeld D., Denkena B.* Advancing cutting technology // *Ann. CIRP.* – 2003. – **52**, N 2. – P. 483–507.
7. *Poulachon G., Bandyopadhyay B. P., Jawahir I. S. et al.* Wear behaviour of cBN tools while turning various hardened steels // *Wear.* – 2004. – **256**, N 3–4. – P. 302–310.
8. *Grzesik W.* Wear of ceramic tools in hard machining // *J. Achiev. Mater. Manuf. Eng.* – 2008. – **26**, N 2. – P. 127–130.
9. *Mookherjee R., Bhattacharyya B.* Development of an expert system for turning and rotating tool selection in a dynamic environment // *J. Mater. Process. Technol.* – 2001. – **113**. – P. 306–311.
10. *Chou Y. K., Evans C. J.* Tool wear mechanism in continuous cutting of hardened tool steels // *Wear.* – 1997. – **212**. – P. 59–65.
11. *Almeida C. H. D., Abrão A. M.* Dimensional and geometric tolerances after machining case hardened AISI 5115 steel // *Int. J. Manuf. Sci. Technol.* – 2002. – **3**. – P. 92–109.
12. *Sobiyi K., Sigalas I., Akdogan G., Turan Y.* Performance of mixed ceramics and cBN tools during hard-turning of martensitic stainless steel // *Int. J. Adv. Manuf. Technol.* – 2015. – **77**, N 5. – P. 861–871.
13. *Hasan S., Tamizhmanii S.* Tool flank wear analysis on AISI 440 C martensitic stainless steel by turning // *Int. J. Mater. Form.* – 2010. – **3**. – P. 427–430.
14. *Abrão A. M., Ribeiro J. L. S., Davim J. P.* Surface integrity // *Machining of Hard Materials* / Ed. J. P. Davim. – London: Springer, 2011. – Chapter 4. – P. 115–141.
15. *Grzesik W., Wanat T.* Hard turning of quenched alloy steel parts using conventional and wiper ceramic inserts // *Int. J. Mach. Tools. Manuf.* – 2006. – **46**. – P. 1988–1995.
16. *Matsumoto Y., Hashimoto F., Lahoti G.* Surface integrity generated by precision hard turning // *Ann. CIRP.* – 1999. – **48**, N 1. – P. 59–62.

Received 27.03.15