

## ELECTRON IRRADIATION TEST FACILITY FOR IRRADIATION OF STRUCTURAL MATERIALS IN CONDITIONS OF MOLTEN SALT REACTOR

*V.M. Azhazha, O.S. Bakai, I.V. Gurin, A.M. Dovbnya, M.V. Demidov, A.I. Zykov, E.S. Zlunit-syn, S.D. Lavrynenko, L.K. Myakushko, O.A. Repikhov, O.V. Torgovkin, B.M. Shirokov, B.I. Shramenko*

*National Science Center "Kharkiv Institute of Physics and Technology"*

*1 Akademichna str., 61108, Kharkiv, Ukraine*

*E-mail: bshram@kipt.kharkov.ua*

A new device, Electron Irradiation Test Facility (EITF), has been created at electron linear accelerator Linac-10 at Accelerator R&D Complex affiliated with NSC KIPT. This facility allows to carry on studies on corrosion resistance of differently shaped samples of the Hastelloy type alloys in the melt of zirconium and sodium fluoride salts at high temperature. A container assembly (CA) that held samples was irradiated for 700 hours in the radiation field of electron beam with the energy  $\sim 10$  MeV and average current  $\sim 500$  microAmps (power  $\sim 5$  kW). The CA consisting of 16 containers (made of a carbon-carbon composite) that were loaded with research samples of Hastelloy alloys in the melt of the salts  $ZrF_4$  и NaF was placed in air-tight protective shell made of stainless steel. During the irradiation, the CA was placed in argon atmosphere. The CA temperature was monitored with three thermocouples. Over the entire length of the irradiation process the stationary temperature regime was provided:  $650^\circ\text{C} \pm 15^\circ\text{C}$ .

### INTRODUCTION

Alongside with the economic benefits of escalation of the atomic energy production, unfortunately, we face a growing menace to the environment on account of accumulation of nuclides with long half-lives, including such nuclides that can well be used for nuclear weapons production. The crucial factor in resolution of those problems would be to employ molten-salt reactors (MSR) with metallic heat carriers that provide for transmutation of the long-lived nuclides into short-lived, eliminating thereby the tangible threat of catastrophic stockpiling of radioactive waste. At the operation temperatures  $650\text{--}800^\circ\text{C}$ , the corrosive influence of molten-salt blanket and metallic heat carriers on the structural materials under the conditions of irradiation is known but a little, the prior reactor materials experience being of little help, since it concerns the reactors of quite different types. With this observation in mind, the challenge of development and testing of the structural materials for the high-temperature reactors employing the metallic heat carriers and MSRs is of extreme importance to those countries that are oriented to utilization of the atomic energy.

Creation of novel promising, radiation-resistant structural materials for atomic reactors of the new generation is intertwined with the necessity to study the behavior of those materials in the conditions that are close to existing in the reactor core at  $T \approx 650^\circ\text{C}$ . These conditions were simulated via electron beam irradiation of the CA containing samples of the structural materials.

The EITF has been built at NSC KIPT Linac-10, designed to sustain long-duration tests of the structural materials in the radiation conditions that are very close to those inside the MSR. To provide for the necessary parameters of the radiation field of irradiation, the electron beam with the energy  $\sim 10$  MeV and power output  $\sim 5$  kW was used. A peculiar characteristic of this ap-

proach to simulation of the conditions of MSR was the fact that heating of the CA up to the required temperature  $T = 650^\circ\text{C} \pm 15^\circ\text{C}$  was performed by electron beam itself owing to the electron ionization losses in the carbon containers that were filled up with research samples of Hastelloy type alloys and melt of the fluoride salts  $ZrF_4$  and NaF.

The radiation control over irradiated materials was implemented, using the industrial type dosimeter "ДБГ-01Н-№ 1519", while the identification of radioactive nuclides in irradiated materials and prediction about their post-irradiation remnant activity vs. time were done on the basis of measurement-takings of gamma-spectra, using a  $\gamma$ -spectrometer of a semiconductor detector of the type "ДГЛК-100 В."

### EITF CONFIGURATION AT LINAC-10

In the result of analysis of technical capabilities of various high-power technological accelerators found at NSC-KIPT Accelerator R&D Complex (EPOS, KUT, KUT-20 and Linac-10) the final choice was made in favor of Linac-10.

This was made because of the following reasons: wide limits of the regulation of the average current value of electrons and energy at the peak of the spectrum; feasibility of controlling the irradiation field dimensions in accordance with the size of the input window in the CA protective shell. The subsequent studies reaffirmed the correctness of this choice.

The preliminary workouts of the necessary irradiation regime on CA mockups, an individual container filled up with Hastelloy type samples and fluoride salt melt and on the CA itself displayed the operability of the EITF, including the temperature measurement system. These tests also allowed to predict the remnant ra-

radioactivity value of CA components after the long-duration irradiation.

The EITF was installed at the linac-10 output (downstream the exit foil), being an autonomous system designed to operate for very long times (1,000... 1,500 h) irradiating with electrons the CAs that hold samples of the structural materials.

A general scheme of the EITF setup at the linac-10 output, emphasizing the functional units, is given in Fig. 1.

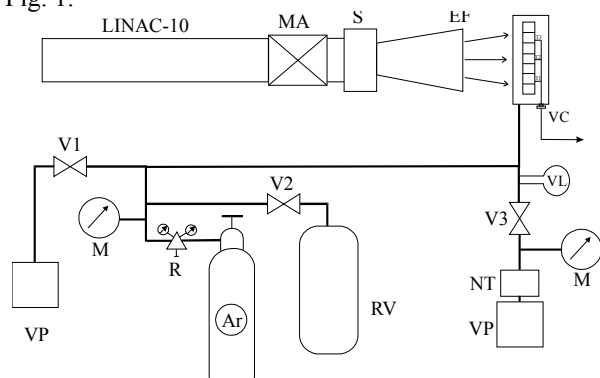

Fig. 1. EITF for simulative testing of structural materials at Linac-10

LINAC-10 – Linear electron accelerator operable at the energy 10 MeV (ЛЭУ – 10); MA – Magnetic analyzer; S – Beam scanner; EF – Exit foil; PBA – Protective CA shell; VC – Vacuum connector for thermocouples; VP – Vacuum pump-valve; M – Manovacuum-meter; Ar – Vessel (with argon); R – Pressure regulator; RV – Damping volume (rubber cushion); VL – Vacuum lamp; NT – Nitrogen trap

The electron beam was swept with the scanner (S) in the vertical, and it corresponded to the size of the protective CA shell window at a distance of 850 mm from the exit foil (EF). Inside the protective shell, there was the CA made of a carbon-carbon composite.

The manifold that was used for remote filling of the protective shell with argon was connected with the high-pressure vessel (Ar) and equipped with the damping volume (RV), “oxygen cushion” with the capacity 75 l, the manovacuum-metric detector (M) and two vacuum pumps (VP) with the nitrogen traps (NT). The airtight protective shell allowed to conduct the radiation tests of containers in argon atmosphere. The heating of the CA up to the required temperature ( $650 \pm 15$ )°C was made directly with the electron beam itself owing to the electron ionization losses in the containers.

The temperature control of the CA was exercised using three thermocouples of the C-K (chromel-kapel) type:  $T_1$ ,  $T_2$  and  $T_3$ .

Fig. 2 shows in more detail the layout of the CA in its protective shell.

The CA (7) is made up of 16 individual containers made of a carbon-carbon composite. The containers are filled up with Hastelloy samples of various modifications in the salt melt of zirconium and sodium fluorides  $ZrF_4$  and NaF.

The containers with the dimensions  $40 \times 40 \times 50$  mm<sup>3</sup> are brought together in common assembly 80 mm wide

and 400 mm tall, placed in the airtight protective shell made of stainless steel (1) which is water-cooled, with the thin input window, being additionally cooled with air flow.

In the upper- and lowermost parts of the assembly, the gas getters (6) abut on the containers, which are a set of thin titanium plates placed in the carbon container with openings. The vacuum pumping of the entire EITF with its subsequent filling with argon is made through the inlet 4.

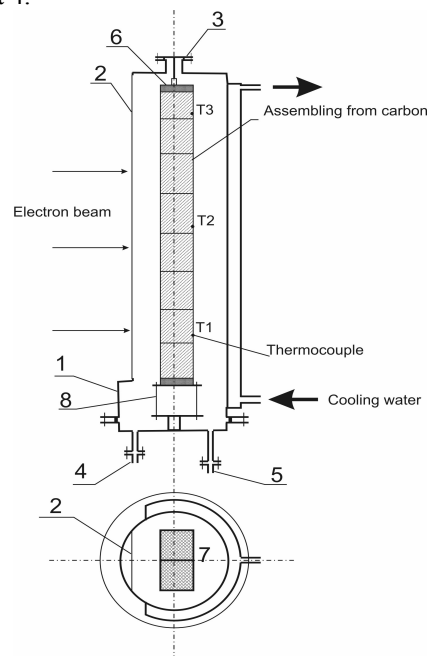

Fig. 2. Container-assembly in its protective shell 1 – Airtight protective shell; 2 – Input window; 3 – Catch; 4 – Flange for vacuum pumping and argon filling; 5 – Inlet for thermocouples  $T_1 - T_3$ ; 6 – Getter (Ti); 7 – Container-assembly made of carbon-carbon composite material; 8 – Heat insulating pillars

To take off the heat  $\approx 5$  kW, the water-cooling of the shell was used. An additional cooling of the assembly was made via air flow through the industrial air vent device of the type “ИЧ-70 № 2,5” with the throughput capacity 900 m<sup>3</sup>/h, which operated through three air conduits with slotted nozzles of a custom configuration, two of which were used for blowing the protective shell from two directions in its rear lateral zones, and one for blowing the protective shell input window foil.

In this way, the EITF positioned at the output of Linac-10 complete with the airtight protective shell and cooling and temperature measurement systems allowed for the simulative radiation via irradiation of containers that hold samples of the structural materials in argon atmosphere.

## PRODUCTION OF NECESSARY RADIATION FIELD AT LINAC-10

The electron beam was swept with the scanner in the vertical over 400 mm ( $\pm 200$  mm off-center). The beam transverse dimensions (in the horizontal)  $\approx 100$  mm ( $\pm 50$  mm off-center) were accounted for by the process of electron scattering at the exit (made of titanium) and

protective (made of aluminum) foils of the scanner vacuum chamber. In this way, at a distance 850 mm from the exit foil, the electron beam looked like a strip 100 mm wide and 400 mm tall. Those beam dimensions corresponded to the input window size of the CA protective shell. To prevent the edge effects on bulky lateral fringes of the input window, a collimator mask made of aluminum with the dimensions 80x400 mm<sup>2</sup> was installed in front of the protective shell input window in exact correspondence with the container assembly size.

At Linac-10, the average accelerated beam current can be adjusted within the limits from  $(I_{av})_{max}=1000$  microAmps to  $(I_{av})_{min} \cong 1$  microAmp. In order to avoid the exit foil overheating, a long work with the current  $\sim 1000$  microAmps is undesirable. The operation value of the current is  $(I_{av})=850$  microAmps. Operation with the concentrated beam (unscanned) is allowable within the limits  $(I_{av})=100$  microAmps. Owing to the summation of microwave power from two klystrons and their excitation from the stable driving generator (DG), Linac-10 allows for a smooth adjustment of the accelerator microwave power within broad limits and, respectively, average beam energy and current. The precision energy adjustment can be done via input phasing of one of the klystrons. This feature turns into an enormous merit during running of the physical experiments and caused the choice of Linac-10 to carry out the present experimental work. The typical beam energy spectrum of Linac-10 is shown in Fig. 3.

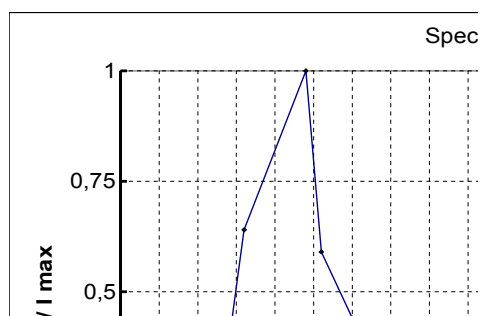

Fig. 3. Electron beam energy spectrum at Linac-10

With a decreasing of the microwave power input into the accelerator, the main spectrum peak energy decreases, while the spectral region near this peak shifts toward smaller energies as a single whole without changing the form of the spectrum. The measurements

taken of the spectra in various regimes of accelerator operation permit to count on energy adjustment of the main spectrum peak from 10 MeV to 7.5 MeV. This situation secures the operation mode choice with the energy below the threshold of the photonuclear reactions ( $\gamma, n$ ) and ( $\gamma, p$ ) on irradiated items. The CA irradiation with electrons was made at the following operation mode of Linac-10:

Linac-10:

Spectrum peak electron energy – 9.6 MeV  
 Total average beam current – 520 microAmps  
 Repetition (group) rate – 150 Hz  
 Effective irradiation area – 80 x 400 mm<sup>2</sup>  
 Irradiation duration – 700 hours  
 Fluence  $\cong 10^{19}$  e/cm<sup>2</sup>

### PROLONGED IRRADIATION OF SAMPLES OF STRUCTURAL MATERIALS AND TEMPERATURE REGIME OF CA IN THE PROCESS OF IRRADIATION

The challenging problem in the initial stage of this research was to provide for the conditions of continuous and prolonged (for 700 h) irradiation with electrons of the CA, while keeping the CA temperature within the limits of  $(650^{\circ}\text{C} \pm 20^{\circ}\text{C})$  in compliance with the Technical Irradiation Assignment. The CA temperature control was maintained with three thermocouples  $T_1 \div T_3$  (Fig. 2) of C-K (chromel-kapel) type that have low sensitivity for irradiation with gamma-quanta and provide for temperature measurements up to 800 °C. The temperature measurements were taken using the multi-channel transducer of the type “Ш 711/И” with the accuracy  $\pm 0,5^{\circ}\text{C}$ .

The adjustment of assigned irradiation temperature regime was done by selection of the accelerator beam current that was continuously monitored and kept at the assigned level. In the course of the entire irradiation run, 700 hours, the registration of temperature readings from all three thermocouples was done every 15 to 20 minutes. In this way, the CA total temperature irradiation regime is depicted as an array of measurements consisting of  $\cong 4,000$  dots.

Fig. 4 presents the results of these measurements in the form of a sampling (out of the total data array) of 700 dots per each thermocouple -  $T_1, T_2$  and  $T_3$ .

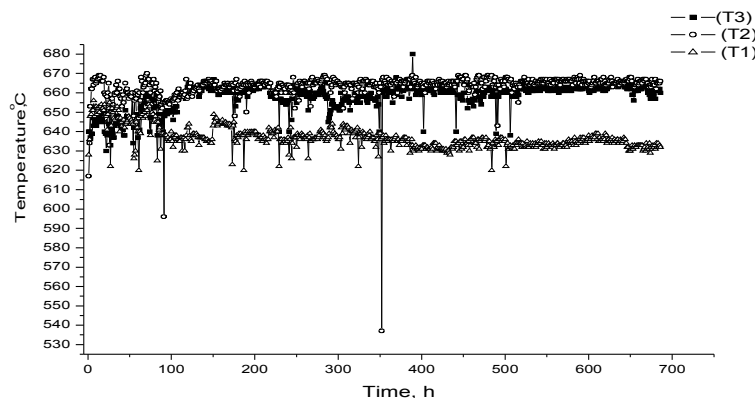

Fig. 4. Container assembly temperature regime during irradiation for 700 hours  
(The dots  $T_1$ ,  $T_2$ , and  $T_3$  stand for readings from the three thermocouples)

One can see from Fig. 4 that the highest temperature was in the center of the CA ( $T_2$ ) and its upper part, while the lowest, in the lower part of the assembly ( $T_1$ ), but these values do not transgress the limits stipulated in the Technical Assignment  $650 \text{ }^\circ\text{C} \pm 20 \text{ }^\circ\text{C}$ .

The dots indicating such temperature that transgresses the above limits (predominantly for  $T_1$ ) correspond to short-duration (minutes) stoppages of the accelerator accounted for by intervention of the high-power electron beam interrupter systems for various reasons that were not caused directly by the operation of the EITF.

The average temperature value  $T(\text{AV})$  and standard deviation (STD) were chosen over samplings of the 700 dots for each thermocouple, using the program EXCEL 5.0.

$$\begin{aligned} T_1(\text{AV}) &= 636.8 \text{ }^\circ\text{C}; \text{ STD} = 5.6 \text{ }^\circ\text{C} \\ T_2(\text{AV}) &= 663.4 \text{ }^\circ\text{C}; \text{ STD} = 6.56 \text{ }^\circ\text{C} \\ T_3(\text{AV}) &= 657.6 \text{ }^\circ\text{C}; \text{ STD} = 7.0 \text{ }^\circ\text{C} \end{aligned}$$

Accordingly, the average CA temperature for 700 hours was  $652.6 \text{ }^\circ\text{C}$  with the deviation alley not exceeding the deviations from the average temperature in accordance with the requirements of Technical Irradiation Assignment:  $(650 \pm 20)^\circ\text{C}$ .

For 700 hours of the irradiation of the CA the fluence was  $\cong 10^{19} \text{ e/cm}^2$ .

The radiation control over irradiated materials was exerted, using the industrial dosimeter of the type "ДБГ-01Н-№ 1519", while the determination of specific activity of the nuclides in irradiated materials [1] and prediction of the behavior of their post-irradiation remnant activity were made on the basis of the measurements of gamma-spectra with the aid of a  $\gamma$ -spectrometer with a semiconductor detector of the type "ДГЛК-100 В".

#### СТЕНД ДЛЯ РАДИАЦИОННЫХ ИСПЫТАНИЙ КОНСТРУКЦИОННЫХ МАТЕРИАЛОВ В УСЛОВИЯХ СОЛЕВОГО РЕАКТОРА

*В.М. Ажжажа, А.С. Бакай, И.В. Гурин, А.Н. Довбня, Н.В. Демидов, А.И. Зыков, Э.С. Злуницын, С.Д. Лавриненко, Л.К. Мякушко, О.А. Репихов, А.В. Торговкин, Б.М. Широков, Б.И. Шраменко*

На линейном ускорителе электронов ЛУ-10 НИК «Ускоритель» ННЦ ХФТИ создана установка «Стенд для радиационных испытаний», позволяющая проводить исследования коррозионной стойкости образцов различных модификаций сплавов типа «хастеллой» в расплаве фторидных солей циркония и натрия при высокой температуре. В радиационном поле пучка электронов с энергией  $\sim 10 \text{ МэВ}$  и средним током  $\sim 500 \text{ мкА}$  (мощностью  $\sim 5 \text{ кВт}$ ) в течение 700 ч проведено облучение сборки контейнеров с образцами. Сборка из 16 контейнеров (из углерод-углеродного композита), заполненных исследуемыми образцами «хастеллой» в расплаве солей  $\text{ZrF}_4$  и  $\text{NaF}$ , помещалась в герметичную защитную оболочку из нержавеющей стали. Сборка при облучении находилась в атмосфере аргона. Температура ее контролировалась тремя термопарами. На протяжении всего процесса облучения обеспечивался стационарный температурный режим  $(650 \pm 15)^\circ\text{C}$ .

#### СТЕНД ДЛЯ РАДІАЦІЙНИХ ВИПРОБУВАНЬ КОНСТРУКЦІЙНИХ МАТЕРІАЛІВ В УМОВАХ СОЛЬОВОГО РЕАКТОРА

*В.М. Ажжажа, О.С. Бакай, И.В. Гури́н, А.М. Довбня, М.В. Демидов, А.И. Зыков, Э.С. Злуницын, С.Д. Лавриненко, Л.К. Мякушко, О.О. Репіхов, О.В. Торговкін, Б.М. Широков, Б.І. Шраменко*

На лінійному прискорювачі електронів ЛП-10 НДК «Прискорювач» ННЦ ХФТІ створено установку «Стенд для радіаційних випробувань», яка дозволяє проводити дослідження корозійної стійкості зразків різних модифікацій сплавів типу «хастеллой» в розплаві фторидних солей цирконію та натрію при високій температурі. У радіаційному полі пучка електронів з енергією  $\sim 10 \text{ Мев}$  та середнім струмом  $\sim 500 \text{ мкА}$  (потужністю  $\sim 5 \text{ кВт}$ ) впродовж 700 годин проведено опромінення збірки контейнерів з досліджуваними зразками. Збірку з 16 контейнерів (з вуглець-вугцевого композиту), заповнених зразками «хастеллой» в розплаві солей  $\text{ZrF}_4$  та  $\text{NaF}$ , розміщено в герметичній захистній оболонці з нержавію-

#### CONCLUSIONS

1. The Electron Irradiation Test Facility (EITF) has been created at Linac-10 at Accelerator R&D Complex affiliated with NSC KIPT. A technology has been perfected for a long-duration irradiation with electron fluxes of samples of the structural materials in such conditions that are close to those existing in the reactor blanket.

2. A technique has been developed for controlled radiation and temperature irradiation regimes in argon atmosphere of the Container Assembly (CA) made of a carbon-carbon composite material (filled up with Hastelloy type samples in the melt of fluoride salts of  $\text{ZrF}_4$  and  $\text{NaF}$ ), and the CA was irradiated with electron beam with the power output about 5kW for 700 hours at the temperature  $T = (650 \pm 15)^\circ\text{C}$ .

3. The experience of radiation tests gained to date, using high-power electron beams, concerning the structural materials in the conditions that are close to those existing in the reactor blanket, shall be employed in further R&D on the structural materials for next-generation reactors.

The research was supported in part by STCU, Project # 294.

#### REFERENCES

A.N. Dovbnya, N.P. Dicky, O.V. Nemashkalo, A.I. Tutubalin, V.L. Uhvarov, A.G. Shepelev, B.I. Shramenko, L.D. Yurchenko. Current status of the problem of nuclide production for various purposes at accelerators and reactors // *Kharkov University bulletin*. 2004, #619, p. 63.

чої сталі. Збірка при опроміненні знаходилась в атмосфері аргону. Температура збірки контролювалась трьома термопарами.. Впродовж процесу опромінення підтримувався стаціонарний температурний режим:  $(650 \pm 15^\circ\text{C})$ .