

A METHOD FOR MINIMIZATION OF CLADDING FAILURE PARAMETER ACCUMULATION PROBABILITY IN VVER FUEL ELEMENTS

S.N. Pelykh, M.V. Maksimov, M.V. Nikolsky
Odessa National Polytechnic University, Odessa, Ukraine
E-mail: 1@pelykh.net; tel. +38(066)187-21-45

It has been proved, that under normal operating conditions the following methods of VVER fuel cladding durability control can be considered as main ones: control of fuel element (FE) construction and fuel physical properties, e.g. making fuel pellets of the most strained axial segment with center holes – M(1); control of the regulating group disposition – M(2); control of the balance of VVER loading regimes – M(3); control of the coolant temperature regime – M(4); control of the FA rearrangement algorithm – M(5). Based on M(*i*), *i* = [1,...,5], a method for minimization of cladding failure parameter accumulation probability in VVER fuel elements by means of control of FE properties at the reactor design and operation stages, lowering the probability of FE cladding failure and increasing the uniformity of burnup, has been developed.

INTRODUCTION

According to the long-term evaluation of nuclear power engineering development in Ukraine fulfilled by the NNEGC “Energoatom”, during the nearest 40 years the nuclear share of the national total electricity generation will stay at the level of 50%. The basis of the national nuclear power engineering will be stably formed by VVER reactors. The evolutionary progress of the Ukrainian nuclear energetics will be based on using reactors having much more severe fuel element (FE) operating conditions as compared with the existing VVER projects, as well as on transition of NPPs into the mode of constant variable loading operation [1].

The simultaneous increase of VVER operating safety, reliability and economic efficiency must be marked as an urgent practical demand. The main factor limiting the increase of these VVER operating characteristics is hermiticity of FE claddings. Considering normal VVER (PWR) operating conditions, at the present level of understanding of the cladding depressurization process, the exact cause of FE failure remains unknown in 20% cases [2].

The change of cladding failure parameter under normal FE operating conditions is limited by the Nuclear Safety Regulations for NPP reactor plants [3]. But no standard methods for calculation of the FE cladding failure parameter $\omega(\tau)$ accumulated by the moment of cladding failure, taking into account the exact sequence (history) of sets of the operating parameters influencing $\omega(\tau)$, for the exact fuel assembly (FA), have been established. Hereupon, there are no established technologies and operational procedures for locating of the depressurized FE in a FA at the operating plants with VVER-1000, for locating of the cladding axial segment (AS) where the depressurization took place, as well as for accounting of the influence of FA rearrangement algorithm on the probability of FE depressurization.

Considering the NNEGC “Energoatom” VVER-1000 units, there has been no integrated data on location of the FE cladding depressurization areas in the FAs containing depressurized FEs, and there has been no published information about the rearrangement

algorithms used before the FE cladding depressurization took place in these FAs. Hence, in order to increase the safety, reliability and economic efficiency of VVER FE operation, the control of FE cladding failure accumulation should be regulated for any FA, with mandatory accounting for the history of sets of the operating parameters influencing the FE cladding failure.

The control of FE cladding failure accumulation should be carried out on the basis of nuclear safety regulations limiting the number of depressurized FEs in the active core, but, at the same time, the requirement of VVER competitiveness restricts the level of conservatism when estimating the FE cladding failure parameter and thus the probability of cladding failure. Considering normal FE operating conditions, the control of FE cladding failure accumulation implies that the FE operating efficiency requirements must be taken into account, as well as the well-known measures for steady decline of the contribution of such cladding failure factors as pellet-cladding mechanical interaction at low fuel burnups, stress-corrosion cracking and, at last, cladding corrosion at high burnups, have been implemented [4].

The estimation of cladding failure parameter based on the known normative strength criterion SC4 developed near 50 years ago is highly uncertain due to incompleteness and inadequacy of the cladding failure accumulation model, specifically due to lack of accounting for the real sequence of sets of operating parameters influencing the cladding failure. Thus this high uncertainty is shown in the value of safety factor $K = 10$ for SC4, which is 6-10 times greater than the safety factors for all the other normative strength criteria. Having regard to this high uncertainty of SC4, the CET-method for calculation of FE cladding failure parameter, under variable loading of VVER-1000, was developed during the 2008 to 2013 period [4]. The CET-method based on creep energy theory (CET) takes into account the influence of the real sequence of sets of the operating parameters on the cladding durability, and another important feature of this method is considering creep as the main physical process of

cladding failure accumulation at FE loading frequencies $\nu \ll 1$ Hz, which are typical for the real VVER operating modes. The CET-criterion of FE cladding depressurization proposed within the bounds of the CET-method is written in the form [5]:

$$\omega(\tau) = A(\tau)/A_0 = \int_0^{\tau} \sigma_e \cdot \dot{p}_e \cdot d\tau / A_0 = 1, \quad (1)$$

where $\omega(\tau)$ is cladding failure parameter; A_0 is the specific dispersion energy $A(\tau)$ at the moment τ_0 of cladding destruction start, MJ/m³; $\sigma_e(\tau)$, $\dot{p}_e(\tau)$ are, respectively, the equivalent stress (Pa) and rate of equivalent creep strain (s⁻¹) for the innermost cladding radial element having the maximum temperature. The limiting component A_0 is found according to the following limiting condition:

$$\lim(dA/d\tau)^{-1} \rightarrow 0 \text{ when } \tau \rightarrow \tau_0. \quad (2)$$

The calculated value of A_0 is 55 MJ/m³ for Zircaloy-4 [4], A_0 is constant for a given material.

Calculation of FE cladding failure parameter using SC4 is characterized by the following shortcomings [6]:

1) According to SC4, the fatigue component of the VVER-1000 FE cladding failure parameter is dominant, while later experimental data obtained by two groups of independent investigators (Sosnin, 1982, USSR and Kim, 2008, South Korea) has proved that the creep mechanism dominates in the process of failure accumulation, when operating VVER/PWR under variable loading with frequencies $\nu \ll 1$ Hz [4].

2) The real sequence of sets of operating parameters influencing the cladding failure is not taken into account when calculating FE cladding failure parameter according to SC4. This is not correct because any dependence of specific dispersion energy $A(\tau)$ on time is strongly nonlinear during a 4-year campaign.

3) The safety factor $K = 10$ for SC4, which is an indication of extremely high uncertainty of cladding failure parameter calculation using SC4. As a result, the permissible intervals for cladding operating parameters are restricted groundlessly, which leads to lowering economic efficiency of FE operation without any obvious increase of FE operation safety.

4) The limiting components n_i^{lim} and t^{lim} of SC4 depend on the real sequence of sets of operating parameters influencing the cladding failure. This fact makes it impossible for SC4 to be used in FE cladding failure probability control, as new values of n_i^{lim} and t^{lim} will be needed for any new set of operating parameters.

Use of the CET-criterion allows us to decrease greatly the uncertainty of cladding failure moment estimation. Setting $A_0 = 30$ MJ/m³, the safety factor K for the CET-criterion is near 2, that is near 5 times smaller than the same for SC4. In addition, the limiting component A_0 does not depend on the sequence of sets of operating parameters influencing the cladding failure (to say briefly – it does not depend on the FE loading

history), which is another great advantage of the CET-criterion comparing with SC4, and this is an additional reason for using the CET-criterion instead of SC4 when controlling the VVER FE cladding failure parameter [6]. The CET-criterion is free of the mentioned disadvantages of SC4, hence the CET-criterion can be used in the task of FE cladding failure probability control.

THE MODEL OF FE BEHAVIOR CONTROL EFFICIENCY

The most important feature of the developed criterion model (CM) of FE behavior control efficiency Eff is taking into account the safety and economic requirements simultaneously [6].

The CM principles are:

1) The FE behavior control goal is an increase of FE normal operating efficiency by means of simultaneous consideration of the FE cladding failure parameter $\omega(\tau)$, as well as the engineering and economic performance of the FE and the whole VVER core.

2) The FE behavior control is carried out on the basis of a priori requirements for FE and core behavior, and setting controlled parameters c_i , $i = [1, \dots, n_c]$, n_c is the number of controlled parameters, and the factors determining the controlled parameters – determining factors (DFs) d_j , $j = [1, \dots, n_d]$, n_d is the number of DFs. Based on a priori requirements for FE and core behavior, the optimal c_i^{opt} and permissible limiting values c_i^{lim} of controlled parameters c_i are established.

3) The structure of the FE behavior control efficiency criterion is constant for all control problems, however, the list of controlled parameters and DFs can be different for different problems.

That is, according to the criterion model, when controlling FE properties and optimizing fuel performance, the parameters to be controlled c_i , as well as the key variable factors to be adjusted d_j , such that these key factors determine the controlled parameters, are defined. On the basis of fuel engineering specifications and economic requirements, the optimal c_i^{opt} and permissible limiting values c_i^{lim} are specified for c_i , so that for all permissible values of c_i the following conditions are satisfied:

$$c_i^{\text{lim}} \leq c_i \leq c_i^{\text{opt}} \text{ or } c_i^{\text{opt}} \leq c_i \leq c_i^{\text{lim}}. \quad (3)$$

After rewriting c_i , c_i^{lim} and c_i^{opt} in dimensionless form:

$$c_i^{\text{lim}*} \leq c_i^* \leq c_i^{\text{opt}*} = 1. \quad (4)$$

Generally, the maximum of efficiency Eff of controlling the FE properties is defined using a criterion having the following structure [6]:

$$\max\{Eff = 1 - L/L^{\text{lim}}\}, \quad (5)$$

where
$$L = \sqrt{\sum_{i=0}^{n_i} (1 - c_{2i+1}^*)^2 + \sum_{j=1}^{n_j} k_{i,j} (1 - c_{2j}^*)^2};$$

$$L^{\text{lim}} = \sqrt{\sum_{i=0}^{n_i} (1 - c_{2i+1}^{\text{lim}*})^2 + \sum_{j=1}^{n_j} k_{i,j} (1 - c_{2j}^{\text{lim}*})^2}, \quad (6)$$

c_{2i+1}^* (c_{2j}^*) are dimensionless controlled parameters with odd (even) indices such that any variation of a dimensional controlled parameter Δc_{2i+1} (Δc_{2j}) yields a variation ΔEff being opposite in sign (equal in sign); n_i (n_j) is the number of controlled parameters such that any variation of a controlled parameter yields a variation ΔEff being opposite in sign (equal in sign); $k_{i,j}$ are weight factors taking into account a difference between $c_{2i+1}^{lim,*}$ and $c_{2j}^{lim,*}$ defined as:

$$k_{i,j} = \left[\frac{1 - c_{2i+1}^{lim,*}}{1 - c_{2j}^{lim,*}} \right]^2. \quad (7)$$

The physical meaning of Eq. (5) is that

– if $c_{2i+1} > c_{2i+1}^{lim,*}$ ($c_{2i+1}^* < c_{2i+1}^{lim,*}$) or $c_{2j} < c_{2j}^{lim,*}$ ($c_{2j}^* < c_{2j}^{lim,*}$), then this controlled parameter gives a negative contribution to the total efficiency Eff ;

– the advantage of one set of determining factors d_j over another is evaluated based on a summation of the advantages given by the controlled parameters c_i .

THE METHOD FOR FE BEHAVIOR CONTROL

The maximum value Eff^{max} of FE behavior control efficiency Eff is found using the criterion given in the general form in [6]. The CM made it possible to propose the general algorithm for FE behavior control using the CET-method, on the basis of iterative calculations of the best set of DFs, in order to meet a priori requirements for FE and core behavior. Besides the CM, a probabilistic model taking into account the uncertainty of knowing DFs was developed within the bounds of the CET-method, thus the generalized method for FE behavior control at VVER design and operational stages was established. The generalized iterative algorithm for FE behavior control includes the methods M(1)...M(5) for control of: 1) FE construction and fuel physical properties, M(1); 2) Regulating group disposition, M(2); 3) Balance of VVER loading regimes, M(3); 4) Coolant temperature regime, M(4); 5) FA rearrangement, M(5) – see Fig. 1 [4].

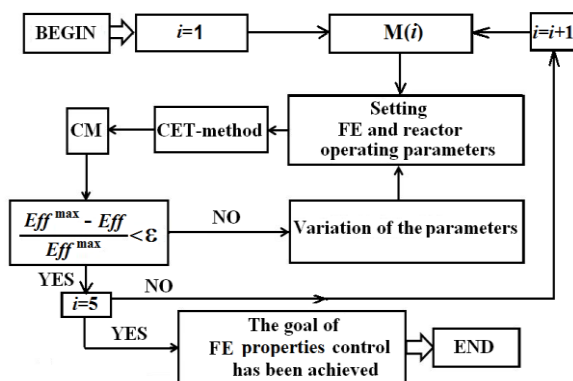

Fig. 1. The generalized method for FE behavior control

The physical meaning of the generalized method for FE behavior control is that the dimension of sets of controlled parameters and DFs is considerably decreased, at the expense of the sequential algorithm according to M(1)...M(5). This allows us to take into account the influence of the main DFs (FE maximum linear heat rate $q_{l,max}$, coolant inlet temperature t_{in} , FE design and core operating characteristics) on the controlled parameters, first of all on $\omega(\tau)$ and fuel burnup $B(\tau)$ describing safety and economic efficiency of FE operation, respectively. In addition, the method for VVER FE behavior control allows us to reduce greatly the dimension of the space of random variables describing the FE behavior.

THE METHOD FOR FE CLADDING FAILURE PROBABILITY CONTROL

The method for FE cladding failure probability control is a consequence of the generalized method for FE behavior control at VVER design and operational stages, so long as the cladding failure parameter control according to each of the methods M(1)...M(5) means, at the same time, the cladding failure probability control. The method for cladding failure probability control includes the following procedures: 1) Using of the sequential algorithm according to M(1)...M(5) and determination of the variants of sets of DFs characterized by maximum values of Eff ; 2) Calculation of the cladding failure probability for these variants; 3) Choice of the best variant among the sets of DFs under the condition of ensuring the minimum cladding failure probability.

Let's adopt the following assumptions:

1) A VVER-1000 FA-averaged FE is considered; the FA type is TVS-A; the FE cladding material is Zircaloy-4 SR.

2) The following daily algorithm of reactor power N maneuvering is used: 100% $N \rightarrow 80\% N \rightarrow 100\% N$.

3) The coolant inlet temperature is kept constant:

$t_{in} = const$.

4) The control assemblies of the reactor control system (RCS) are placed in the core according to the A-algorithm of core power control. When using the A-algorithm, the 10th regulating group is used only, while the control rods of all the other groups are completely removed from the core [6].

5) M(5), the FA rearrangement control method is applied for control of the FE cladding failure probability.

THE FA REARRANGEMENT MODEL

When modelling rearrangements of FAs in the core, a core segment containing 1/6 of all the FAs (excluding the FA placed in the central core cell 82), as well as 1/6 of all the regulating units used for reactor power maneuvering, was considered [6]. The dedicated core segment has not more than 7 FAs of each campaign year. The distribution of FAs by campaign year in the core segment was found using the distribution of long-lived and stable fission products specified for the start of the 5th four-year campaign of Khmelnitskiy NPP Unit 2 (Fig. 2).

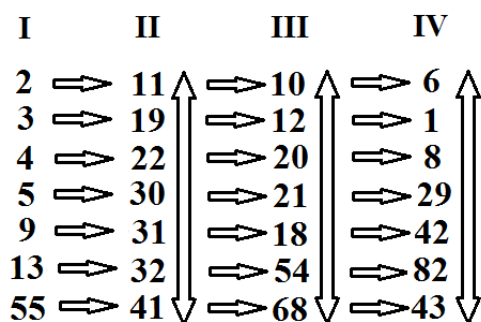

Fig. 2. Rearrangements of FAs in the core segment:
(number) FA cell number:
(roman numerals I, II, III and IV) 1st, 2nd, 3rd
and 4th campaign year, respectively

Hence, it can be assumed that at the beginning of each campaign year the FAs are placed according to the distribution shown in Fig. 2. This distribution was calculated using the program for FA rearrangement optimization, on the basis of minimizing the coefficient of radial nonuniformity of power flux in the core [7].

At NPPs with VVER-1000 the following approach is used mainly [8]: a 1st or 2nd year FA is placed in cell 82, and 7 core cells are appointed for FAs of each year, with the exception of 4th year FAs which can be placed in 6 cells only. In this case cell 82 is not considered when optimizing FA rearrangements in the core segment (see Fig. 2).

THE METHOD FOR FA REARRANGEMENT CONTROL

The method for FA rearrangement control taking into account $\omega(\tau)$ and $B(\tau)$ was developed on the basis of CET-method and CM. Considering all the FAs used in the j th FA rearrangement algorithm, the maximum ω_j^{\max} and average $\langle \omega \rangle_j$ values of FE cladding failure parameter, as well as the minimum value B_j^{\min} of fuel burnup are considered as the controlled parameters, while the FA rearrangement algorithm is the variable determining factor [5, 6]. A random choice of cells in the core segment using the MATLAB function “rand” [9] was adopted.

Using the “Reactor Simulator” (RS) code [10], developed for uniform fuel columns including FAs of a specified design/producer, the relative power coefficients were calculated in the all segment cells for all the FA-averaged FE axial segments, at reactor power levels 80 and 100%. Using the “Femaxi” code [11], the CET-criterion at $A_0 = 30 \text{ MJ/m}^3$ and the MATPRO-A model of cladding corrosion [12], the FE cladding’s most stressed AS was determined (AS 6).

Further for the adopted model of FA rearrangements (see Fig. 2), setting the control rod movement amplitude sufficient for stabilization of the core axial offset, $\omega(1460 \text{ days})$ and $B(1460 \text{ days})$ were calculated in the cladding’s most stressed AS 6. 18 FA rearrangement algorithms containing 126 different FA rearrangements were analyzed, where 16 algorithms containing 112 rearrangements were randomly chosen, while 2 algorithms were practically used at Zaporizhzhya NPP, Unit 5 [8]. These 2 practical algorithms used during the

yearly campaigns 22 and 23 (algorithms 17 and 18, respectively), as well as three random algorithms (2, 3, and 6) are shown in Table 1.

The optimal $\{\omega^{\text{opt}}, \langle \omega \rangle^{\text{opt}}, B^{\text{opt}}\}$ and permissible limiting values $\{\omega^{\text{lim}}, \langle \omega \rangle^{\text{lim}}, B^{\text{lim}}\}$ for the controlled parameters $\{\omega_j^{\max}, \langle \omega \rangle_j, B_j^{\min}\}$ are established [5, 6]:

$$\begin{aligned} \omega^{\text{opt}} &= \min\{\omega_j^{\max}\}; \\ \langle \omega \rangle^{\text{opt}} &= \min\{\langle \omega \rangle_j\}; \\ B^{\text{opt}} &= \max\{B_j^{\min}\}. \end{aligned} \quad (8)$$

$$\begin{aligned} \omega^{\text{opt}} &\leq \omega_j^{\max} \leq \omega^{\text{lim}}; \\ B^{\text{lim}} &\leq B_j^{\min} \leq B^{\text{opt}}; \\ \langle \omega \rangle^{\text{opt}} &\leq \langle \omega \rangle_j \leq \langle \omega \rangle^{\text{lim}}. \end{aligned} \quad (9)$$

Thus the following restrictions are fulfilled for the corresponding dimensionless parameters:

$$\begin{aligned} \omega^{\text{lim},*} &\leq \omega_j^{\max,*} \leq 1; \\ \langle \omega \rangle^{\text{lim},*} &\leq \langle \omega \rangle_j^* \leq 1; \\ B^{\text{lim},*} &\leq B_j^{\min,*} \leq 1, \end{aligned} \quad (10)$$

where

$$\begin{aligned} \omega^{\text{lim},*} &= \frac{1 - \omega^{\text{lim}}}{1 - \omega^{\text{opt}}}; \quad \omega_j^{\max,*} = \frac{1 - \omega_j^{\max}}{1 - \omega^{\text{opt}}}; \\ \langle \omega \rangle^{\text{lim},*} &= \frac{1 - \langle \omega \rangle^{\text{lim}}}{1 - \langle \omega \rangle^{\text{opt}}}; \quad \langle \omega \rangle_j^* = \frac{1 - \langle \omega \rangle_j}{1 - \langle \omega \rangle^{\text{opt}}}; \\ B^{\text{lim},*} &= B^{\text{lim}} / B^{\text{opt}}; \quad B_j^{\min,*} = B_j^{\min} / B^{\text{opt}}. \end{aligned} \quad (11)$$

Since the length of $[B^{\text{lim},*}; 1]$ interval can be considerably greater than the length of $[\omega^{\text{lim},*}; 1]$ interval, two main approaches can be proposed:

1) The strict condition is set [5]:

$$\omega^{\text{lim},*} = \langle \omega \rangle^{\text{lim},*} = B^{\text{lim},*}. \quad (12)$$

2) Weight factors are used – see Eq. (7) [6].

Though the last approach is more universal, merely for demonstration purposes, the first approach is used here. Hence having some value of ω^{lim} , the corresponding values of $\langle \omega \rangle^{\text{lim}}$ and B^{lim} are defined from equations (11) and (12).

Using Eq. (12), as a simple illustrative example of the criterion model, in order to compare the efficiency of different FA rearrangement algorithms, the criterion of FE behavior control efficiency Eff is used in a simplified form [5], such that:

$$\max\{Eff_j\}, \quad (13)$$

where

$$Eff_j = 1 - \frac{\sqrt{(1 - \omega_j^{\max,*})^2 + (1 - \langle \omega \rangle_j^*)^2 + (1 - B_j^{\min,*})^2}}{\sqrt{3} |1 - \omega^{\text{lim},*}|}.$$

The physical meaning of Criterion (13) is:

1) If $\omega_j^{\max} > \omega^{\text{lim}}$ or $\langle \omega \rangle_j > \langle \omega \rangle^{\text{lim}}$ or $B_j^{\min} < B^{\text{lim}}$, then the corresponding component gives a negative contribution to the total efficiency Eff_j .

2) Advantage of some algorithm over another is determined on the basis of summation of advantages given by each of the components $\{\omega_j^{\max}, \langle \omega \rangle_j, B_j^{\min}\}$.

According to Eq. (3): $\omega^{\text{opt}} = 6.85\%$. For example, assuming $\omega^{\text{lim}} = 8.5\%$, it follows from Eq. (6):

$$\omega^{\text{lim},*} = 0.982.$$

Using Eq. (8), the efficiency Eff_j of FE behavior control was found for 18 algorithms, $j = (1...18)$.

$Eff_2 = \min\{Eff_j\}$, $Eff_3 = \max\{Eff_j\}$, $Eff_6 \in [Eff_2, Eff_3]$, Eff_{17} and Eff_{18} are listed in Table 2.

Table 1

Cladding failure parameter and burnup for AS 6

Algorithm	Rearrangement	$A, \text{MJ/m}^3$	$\omega(\tau) = A/A_0, \%$	$B, \text{MW}\cdot\text{d/kg}$
2	5-30-10-43	1.838	6.127	63.04
	9-11-20-1	1.443	4.81	57.26
	3-22-54-29	1.843	6.143	63.89
	13-19-21-42	2.652	8.84	68.13
	2-31-18	1.209	4.03	47.61
	55-41-12-6	1.955	6.517	59.1
	4-32-68-8	1.368	4.56	57.02
3	9-19-21-8	2.253	7.51	62.49
	5-41-68-43	1.391	4.637	60.47
	55-22-10	2.167	7.223	54.67
	13-11-20-6	1.421	4.737	56.8
	3-30-54-1	1.387	4.623	55.04
	4-32-18-42	1.722	5.74	62.69
	2-31-12-29	1.976	6.587	63.88
6	55-11-18-43	1.568	5.227	63.84
	13-32-20	2.019	6.73	54.19
	3-31-10-8	1.816	6.053	59.65
	9-19-68-42	2.054	6.847	65.55
	4-41-12-29	1.935	6.45	64.93
	2-30-21-6	1.522	5.073	54.82
	5-22-54-1	1.238	4.127	53.05
17	2-22-12-6	1.463	4.877	54.35
	3-41-29	1.184	3.947	48.8
	4-11-68-43	1.078	3.593	60.63
	5-19-10-8	1.498	4.993	57.18
	9-30-20-1	2.058	6.86	59.39
	13-32-21-42	2.667	8.89	68.23
	55-31-54-18	2.437	8.123	67.45
18	2-22-21-6	1.55	5.167	54.86
	3-41-68	1.18	3.933	48.83
	4-11-29-18	1.159	3.863	60.84
	5-19-20-1	1.449	4.83	54.55
	9-32-12-42	2.586	8.62	67.86
	13-30-10-43	2.551	8.503	67.73
	55-31-54-8	1.982	6.607	61.37

Table 2

j	ω_j^{\max} , %	$\langle \omega \rangle_j$, %	B_j^{\min} , MW·d/kg	$\omega_j^{\max,*}$	$\langle \omega \rangle_j^*$	$B_j^{\min,*}$	Eff_j
2	8.84	5.86	47.6	0.979	0.999	0.871	-3.2
3	7.51	5.87	54.7	0.993	0.999	1	0.77
6	6.85	5.79	53.1	1	1	0.970	0.039
17	8.89	5.9	48.8	0.978	0.999	0.893	-2.5
18	8.62	5.93	48.8	0.981	0.998	0.893	-2.48

In the deterministic case of FA rearrangement optimization under consideration, the goal of FA rearrangement control has been achieved for algorithm 3. Besides simultaneous lowering of ω_j^{\max} and $\langle \omega \rangle_j$, as well as increasing of B_j^{\min} , the physical meaning of

increasing Eff_j is lowering of the variation intervals $2 \cdot \Delta\omega_j$ (1460 d) and $2 \cdot \Delta B_j$ (1460 d) within the j th rearrangement algorithm, for the most stressed axial segment (AS 6) in the FA-averaged FE (Table 3).

Table 3

j	Eff_j	$\langle \omega \rangle_j$, %	$2 \cdot \Delta\omega_j$, %	$\langle B \rangle$, MW·d/kg	$2 \cdot \Delta B_j$, MW·d/kg
2	-3.2	5.86	4.81	59.43	20.52
3	0.77	5.87	2.887		9.21
6	0.039	5.79	2.72		12.5
17	-2.5	5.9	5.3		19.43
18	-2.48	5.93	4.757		19.03

The method for FA rearrangement control allows us to find rearrangement algorithms having maximum uniformity of cladding damage and fuel burnup among all the FAs for a rearrangement algorithm, and, therefore, to develop the method for FE cladding failure probability control increasing safety and economic efficiency of FE operation. The method for FE behavior control was developed for the case of FA-averaged FE. This approach is reasonable since it allows us to find the principles of FE behavior control. Within the bounds of this approach the CET-criterion is most important among all the strength criteria, although use of the CET-criterion implies taking into account the restrictions specified by all existing normative FE strength criteria, with the exception of SC4.

The calculations of VVER-1000 FE cladding failure parameter carried out according to the CET-method have shown that, when considering all the FEs situated in the studied FA, if the nonuniformity of stationary power flux and variable linear heat rate (LHR) jumps is not taken into account, then for normal operating conditions the normative strength criterion SC1 (the hoop stress σ_θ in FE cladding is limited by the condition: $\sigma_\theta < 250$ MPa, the safety factor $K = 1.2$) has no limiting significance when controlling cladding damage. But it should be stressed that, if taking into

account the nonuniformity of stationary power flux and LHR jumps among all the FEs of the FA, then an increased limiting significance of SC1 should be expected.

THE METHOD FOR FE CLADDING FAILURE PROBABILITY CALCULATION

The FA-averaged FE cladding failure parameter, for the j th rearrangement algorithm, was considered as a random variable ω_j^{rand} distributed according to the normal law in the range $[\langle \omega_j^{\text{rand}} \rangle - \Delta\omega_j^{\text{rand}}; \langle \omega_j^{\text{rand}} \rangle + \Delta\omega_j^{\text{rand}}]$, $j = \{2; 3; 6; 17; 18\}$. Taking into account the three-sigma rule, the standard deviations $\sigma(\omega_j^{\text{rand}})$ of the random variable ω_j^{rand} were found, based on $\Delta\omega_j^{\text{max}}$ found from the data listed in Table 1. The FA-averaged FE cladding failure probability P_j was calculated for the j th FA rearrangement algorithm using the following equation (Table 4):

$$P_j = \int_{\omega_{\text{lim}}}^{\omega_{\text{max}}} \frac{\exp\left[-\frac{(\omega_j^{\text{rand}} - \langle \omega_j^{\text{rand}} \rangle)^2}{2[\sigma(\omega_j^{\text{rand}})]^2}\right]}{\sigma(\omega_j^{\text{rand}})\sqrt{2\pi}} \cdot d\omega_j^{\text{rand}} \quad (14)$$

Table 4

Cladding failure probability for the j th algorithm

j	$\omega^{\text{lim}}, \%$	$\langle \omega_j^{\text{rand}} \rangle, \%$	$2 \cdot \Delta \omega_j^{\text{rand}}, \%$	$\omega_j^{\text{min}}, \%$	$\omega_j^{\text{max}}, \%$	$\sigma(\omega_j^{\text{rand}}), \%$	P_j
2	8.5	6.435	4.81	4.03	8.84	0.8017	0.0035
3		6.067	2.887	4.623	7.51	0.4812	0
6		5.487	2.72	4.127	6.847	0.4533	0
17		6.242	5.3	3.593	8.89	0.8833	0.0039
18		6.242	4.757	3.863	8.62	0.7928	0.00085

The use of Eq. (14) is characterized by an error derived from the fact that $\langle \omega_j^{\text{rand}} \rangle \neq \langle \omega \rangle_j$ (see Tables 3 and 4):

$$\max\left\{\frac{|\langle \omega_j^{\text{rand}} \rangle - \langle \omega \rangle_j|}{\langle \omega \rangle_j}\right\} \approx 10\%.$$

The precision of the probability calculation can be increased by means of modifying Eq. (14) using a combination of truncated normal distributions.

The number of FEs in a FA is 312, and there are six 4th campaign year FAs within the core segment, thus the total number of FEs in six 4th year FAs is $n = 312 \cdot 6 = 1872$.

After 4 campaign years, knowing the FA-averaged FE cladding failure probability P_j for the j th algorithm,

the cladding failure probability for k FEs from 1872 FEs situated in six 4th year FAs within the core segment, is found using the Bernoulli formula

$$P_{j,1872}(k) = C_{1872}^k \cdot (P_j)^k \cdot (1 - P_j)^{1872-k}, \quad (15)$$

$$\text{where } C_{1872}^k = \frac{1872!}{k! \cdot (1872 - k)!}.$$

When considering six absolutely identical core segments, the event “FE cladding failure” in a segment means the simultaneous cladding failure in the corresponding FE for all the other segments. After four campaign years, the cladding failure probability for $6 \cdot k$ FEs from 11232 FEs situated in 36 4th year FAs within the whole core, is found from Eq. (15) – see Table 5:

$$P_{j,11232}(6 \cdot k) = P_{j,1872}(k). \quad (16)$$

Table 5

The probability of cladding failure in $6 \cdot k$ FEs, %

j	The number of depressurized claddings ($6 \cdot k, k = 0, 1, 2, \dots, 12$)												
	0	6	12	18	24	30	36	42	48	54	60	66	72
	The probability of failure of $6 \cdot k$ claddings, %												
2	0.14	0.93	3	6.55	10.9	14.3	15.7	14.7	12	8.76	5.72	3.41	1.85
3	100	0											
6	100	0											
17	0.07	0.49	1.79	4.36	7.97	11.6	14.2	14.8	13.5	11	8	5.3	3.22
18	20.4	32.4	25.8	13.7	5.44	1.72	0.46	0.1	0				

Algorithms 3 and 6 dominate all the other options, having the cladding failure probability near 0, based on the assumed limiting value $\omega^{\text{lim}} = 8.5\%$ for the FE cladding failure parameter. The probability of cladding failure in $6 \cdot k < 18$ FEs, i. e. $P(6 \cdot k < 18)$ is 4.07, 2.4 and 78.6% within algorithms 2, 17 and 18, respectively. Whereas the probability of cladding failure in $18 \dots 72$ FEs, i. e. $P(18 \leq 6 \cdot k \leq 72)$ is 93.9, 94 and 21.4% within algorithms 2, 17 and 18, respectively (Fig. 3).

The problem of limitation of VVER (PWR) FE cladding failures is being investigated by the world scientific community and has been still unsolved.

Therefore it is essential to compare the verification model calculations, based on the proposed method for minimization of cladding failure parameter accumulation probability in VVER fuel elements, with corresponding experimental data.

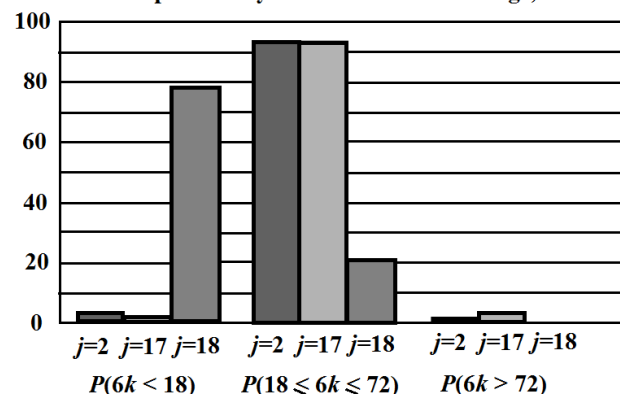
The probability of failure in $6 \cdot k$ claddings, %Fig. 3. The probability of failure in $6 \cdot k$ claddings within algorithms 2, 17, and 18

CONCLUSIONS

1. Considering the VVER-1000 FA-averaged FE, the method for calculation of the FE cladding failure probability depending on the exact sequence of sets of FA operating parameters influencing the FE cladding damage, has been developed.

2. Taking into account all the FAs exploited in the core during four years, assuming $\omega^{\text{lim}} = 8.5\%$ as the limiting value for FE cladding failure parameter, the probability of cladding failure in ≥ 18 FEs within practically used algorithms 17 and 18 is 97.6 and 21.4%, respectively. Assuming $\omega^{\text{lim}} = 8.5\%$, FA rearrangement algorithms 3 and 6 have zero cladding failure probability. Thus the method for FE cladding failure probability control allows us to find the FA rearrangement algorithms having zero FE cladding failure probability.

3. The accuracy of FE cladding failure probability calculation can be essentially increased by means of taking into account the nonuniformity of stationary power flux and LHR jumps among all the FEs of the FA, as well as the uncertainty of factors (e.g., FE maximum LHR) determining the cladding failure parameter.

4. Based on the developed method for FE cladding failure probability control, it is reasonable to work out an automated program-technical complex increasing safety and economic efficiency of VVER-1000 operation.

NOMENCLATURE

CET – creep energy theory.

DF – determining factor.

FA – fuel assembly.

FE – fuel element.

LHR – linear heat rate.

M(1)...M(5) – methods for FE behavior control.

SC – strength criterion.

VVER – PWR-type reactor.

REFERENCES

1. N.I. Vlasenko. A long-term evaluation of nuclear power engineering development in Ukraine // *Proc. of the XX Int. Conf. on Physics of Radiative Effects and Radiative Study of Materials*, Alushta, NSC “Kharkov Institute of Physics and Technology”, 2012, p. 7-8.

2. R. Yang, B. Cheng, J. Deshon, et al. Fuel R & D to Improve Fuel Reliability // *Journal of Nuclear Science and Technology*. 2006, v. 43, N 9, p. 951-959.

3. *Nuclear safety regulations for NPP reactor plants*. M.: “The Federal Service for Ecological, Technological and Nuclear Supervision”, 2008, 21 p.

4. S.N. Pelykh. *Grounds of VVER fuel element behavior control*. Saarbrücken: “Palmarium Academic Publishing”, 2013, 168 p.

5. S.N. Pelykh, M.V. Maksimov, V.E. Baskakov. Grounds of VVER-1000 fuel cladding life control // *Annals of Nuclear Energy*. 2013, N 58, p. 188-197.

6. S.N. Pelykh, M.V. Maksimov, G.T. Parks. A method for VVER-1000 fuel rearrangement optimization taking into account both fuel cladding durability and burnup // *Nuclear Engineering and Design*. 2013, v. 257, N 4, p. 53-60.

7. *The nuclear steam-generating plant database for design accident analysis at the South-Ukraine NPP, Unit 1*. Yuzhnoukrainsk: “SUNPP”, 1999, 643 p.

8. R.Y. Vorobyev. *Albums of neutron-physical characteristics of the reactor core, Unit 5, Zaporizhzhya NPP. Campaigns 20-23*. Energodar: “Zaporizhzhya NPP”, 2008-2011, 323 p.

9. *MATLAB Version 7.10.0*. Natick, Massachusetts: “The MathWorks Inc.”, 2010, 512 p.

10. P.E. Philimonov, V.V. Mamichev, S.P. Averyanova. The “reactor simulator” code for modelling of maneuvering VVER-1000 regimes // *Atomnaya Energiya*. 1998, v. 84, N 6, p. 560-563.

11. M. Suzuki. *Light-water reactor fuel analysis code FEMAXI-V (Ver.1)*. Tokai: “Japan Atomic Energy Research Institute”, 2000, 285 p.

12. M. Suzuki. *Modelling of light-water reactor fuel element behavior in different loading regimes*. Odessa: “Astroprint”, 2010, 248 p.

Статья поступила в редакцию 07.04.2014 г.

МЕТОД МИНИМИЗАЦИИ ВЕРОЯТНОСТИ НАКОПЛЕНИЯ ПОВРЕЖДЕННОСТИ ОБОЛОЧЕК ТВЭЛОВ ВВЭР

С.Н. Пельх, М.В. Максимов, М.В. Никольский

Доказано, что при нормальных условиях эксплуатации следующие методы управления долговечностью оболочек ТВЭЛОВ ВВЭР можно рассматривать как основные: управление конструкционными свойствами ТВЭЛА и физическими свойствами топлива, например изготовление топливных таблеток наиболее напряженного аксиального сегмента с центральными отверстиями – M(1); управление расположением регулирующей группы – M(2); управление балансом режимов нагружения ВВЭР – M(3); управление температурным режимом теплоносителя – M(4); управление алгоритмом перестановок ТВС – M(5). Основываясь на M(i), $i = [1, \dots, 5]$, разработан метод минимизации вероятности накопления поврежденности оболочек ТВЭЛОВ ВВЭР путем управления свойствами ТВЭЛОВ на стадиях проектирования и эксплуатации реактора, позволяющий снизить вероятность разгерметизации оболочек и повысить равномерность выгорания топлива.

МЕТОД МІНІМІЗАЦІЇ ІМОВІРНОСТІ НАКОПИЧЕННЯ ПОШКОДЖЕНОСТІ ОБОЛОНОК ТВЕЛІВ ВВЕР

С.М. Пелих, М.В. Максимов, М.В. Нікольський

Доведено, що за нормальних умов експлуатації наступні методи управління довговічністю оболонок твелів ВВЕР можна розглядати як основні: управління конструкційними властивостями твела і фізичними властивостями палива, наприклад виготовлення паливних пігулок найбільш напруженого аксіального сегмента з центральними отворами – М(1); управління розташуванням регулюючої групи – М(2); управління балансом режимів навантаження ВВЕР – М(3); управління температурним режимом теплоносія – М(4); управління алгоритмом перестановок ТВЗ – М(5). Грунтуючись на М(і), $i = [1, \dots, 5]$, розроблений метод мінімізації імовірності накопичення пошкодженості оболонок твелів ВВЕР шляхом управління властивостями твелів на стадіях проектування і експлуатації реактора, що дозволяє зменшити вірогідність розгерметизації оболонок і підвищити рівномірність вигорання палива.