

VARIANTS OF NESTOR INJECTION REMOTE CONTROL

Yu.I. Akchurin, M.V. Ivakhnenko, E.I. Orlova

National Science Center "Kharkov Institute of Physics and Technology", Kharkov, Ukraine

The two variants of remote control linac-60 for injection of the electron beam in the storage-ring "NESTOR" is described. First variant of the autonomous remote control for linac design from the decoder 155ID3. In the second variant use ADAM-4051 as encoder, while the decoders are the controllers ADAM-5051E, using for auto-locking and phase control linac. The controllers help automation process diagnostics of this accelerator during its malfunction.

PACS: 29.17.+w

From the view point of control the linac-60 is designed for the injection of the electron beam in the storage-ring "NESTOR" consisting of 3 groups of objects: the injector itself and 2 accelerating sections. For their auto-locking and control, the section panel provides 2 controllers ADAM-5051E [1], which make it possible to perform failure diagnostics of this accelerator during its malfunction up to displaying the linac mimic diagram with glowing dots on a computer screen showing the location of the fault [2]. Equipment linac is arranged in 3 rooms: bunker, klystron hall and modulator basement.

And in an emergency it is important to know which way to go and what take along with for fixing the problem.

Remote Control (RC) based on these controllers seemed to us to be impossible as would distract them from their primary functions: control the linac operation mode and lock the main elements of its equipment at a variation from the norm. Developed was the autonomous remote control (RC) circuit similar to that suggested for modification of the linac-2000 RC circuit [3] and having been successfully operating on the EPOS accelerator at present [4].

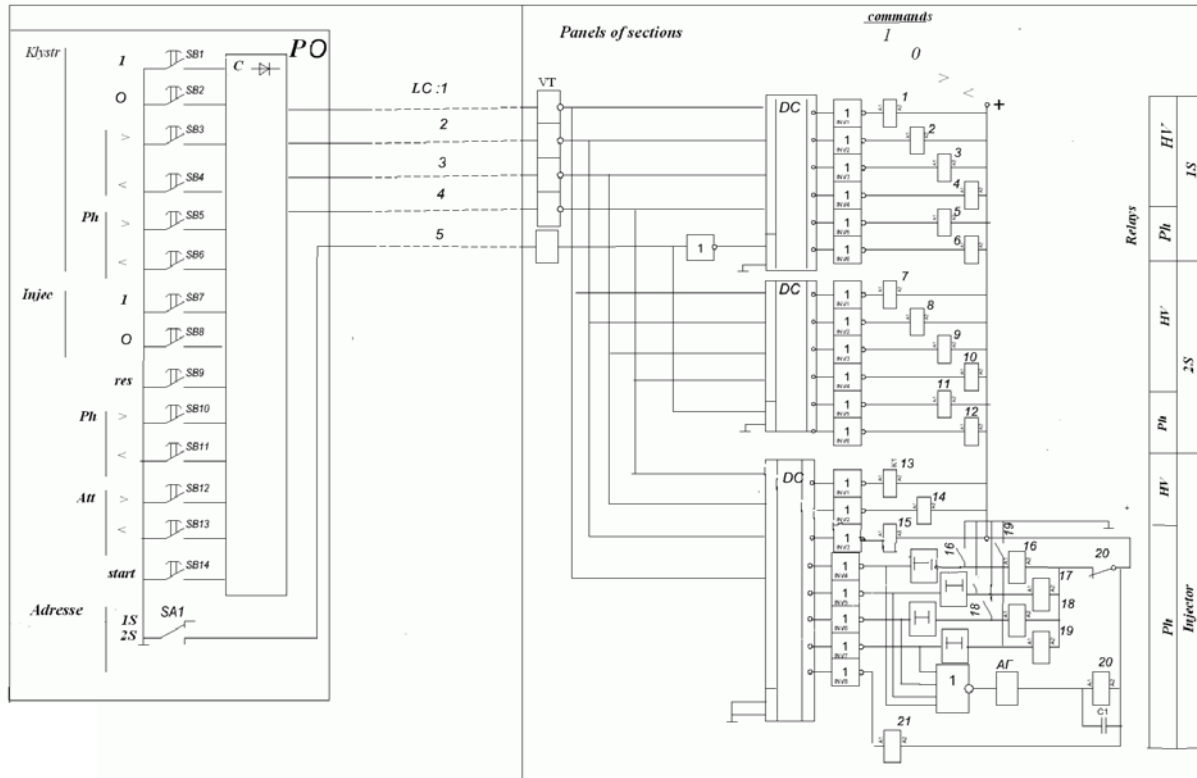

Fig. 1. First variant RC linac-60: PO – operator control panel; IS, 2S – section; Ph – phase; Att – amplitude; G – >; L – <; SB, SA – button; C – the encoder; LC – link; VT – level reduct; DC – decoder; [—] – pauser

In the developed remote control circuit for linac – 60 (Fig. 1) diode encoder, the commands are transmitted through a communication line to the section panel having a high level where their levels are reduced to 5 V (Fig. 2). Section decoders of the 155ID3-series are connected as "exclusive OR circuit", which makes it possible to use one button for the same type of commands, reducing the size of operator control panel (software). For phasing of high-frequency (RF) field of injector step-motors of the type relay are used as a drive. Pulse generator to them consists of a power supply unit

(PSU), self-oscillator and amplifier-shaper of current signals (Fig. 3).

The feature of the self-oscillator circuit is the formation of the last pulse of specified duration regardless of the moment you release the control button "start " for software (see Figs. 1, 4), which enables to precise running of mechanics and besides, unloads the final control relays of the same type against heavy current switching handing it over to starter "Start". The oscillator frequency is of 25...30 Hz.

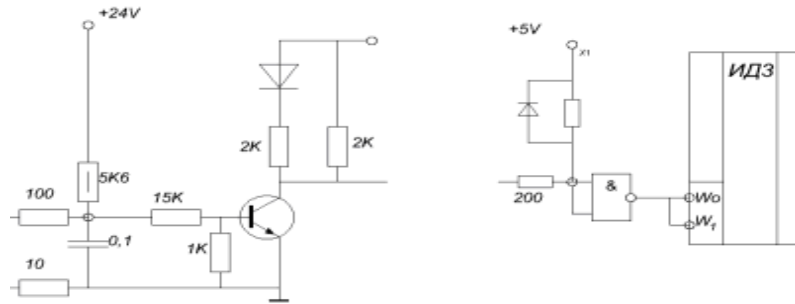

Fig. 2. The reducer of level

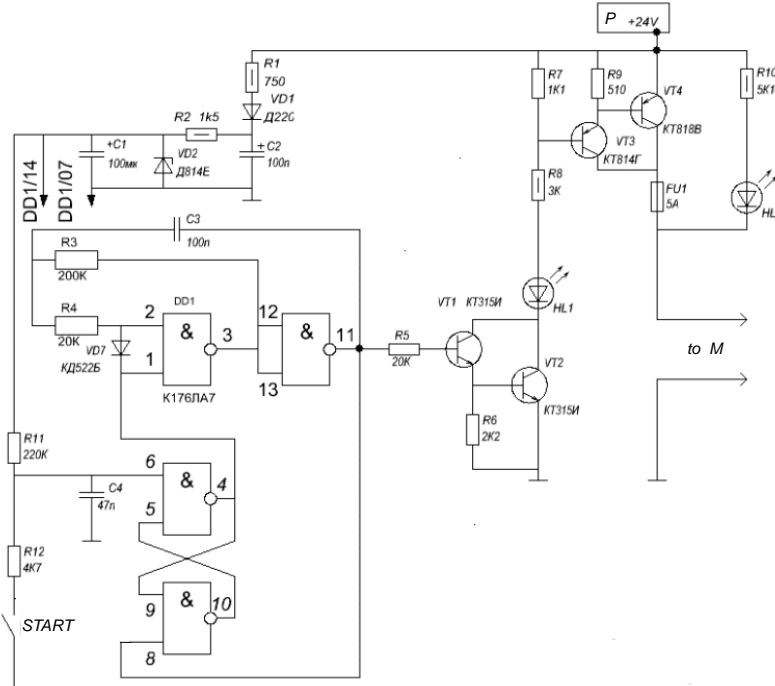

Fig. 3. Pulse generator: P – power supply unit; DD – integrated circuit; M – step-motor

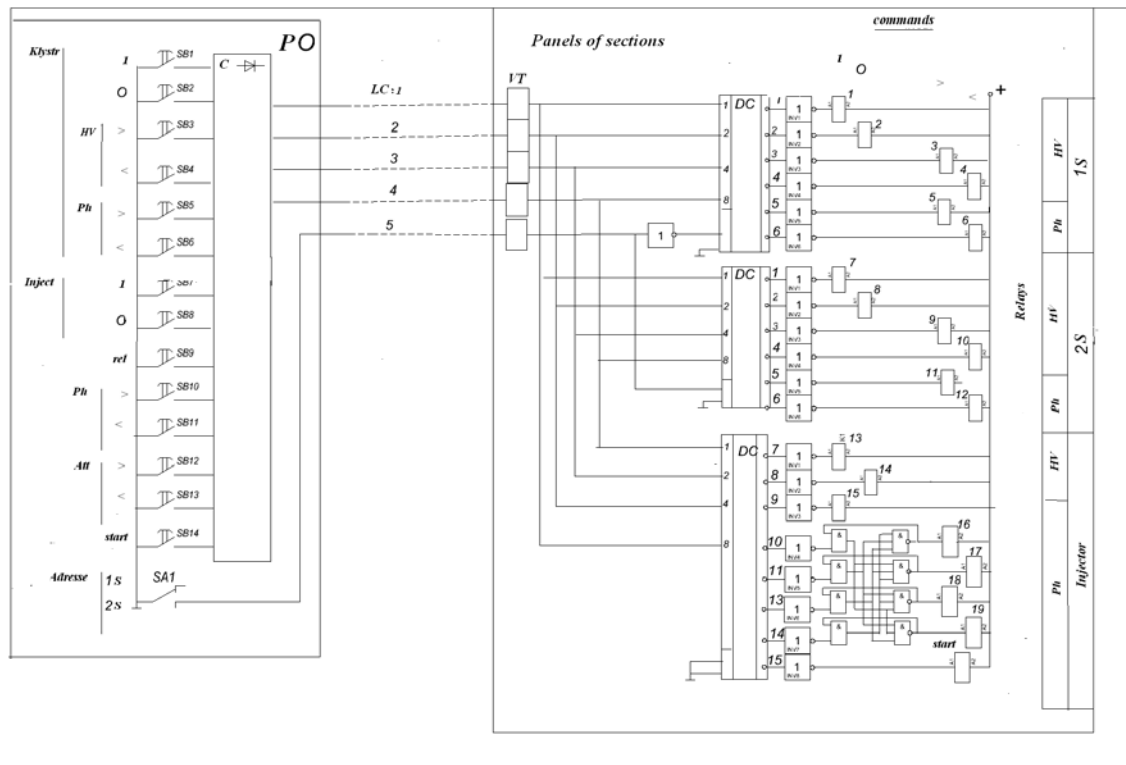

Fig. 4. The first improving variant RC of linac-60: PO – the operator control panel; 1S, 2S – section; Ph – phase; Att – amplitude; G – >; L – <; SB, SA – the button; C – the encoder; LC – link; VT – level reduct; DC – decoder; HV – high voltage

In this regard, the stepped motor control is revised so that not only address and object should be preselected, but also the direction of motion as in the ELA-40 [5]. In the section panel selection of the object for phasing and movement direction is carried out through PAG, the memory is organized through the final control relay contacts of the phase shifter or attenuator. The delay line for switching these relays are required to switch univibrator repeater PAG for having time to turn off the previous control, and the capacitor parallel to the relay coil should extend the uni-vibrator pulse for correct operation of the relay. This difficulty can be avoided if, instead of a relay to apply the integrated circuit switch. Then the final layout of the remote control injector drive "Nestor" will look like as in Fig. 4. The power module is presented on Fig. 5.

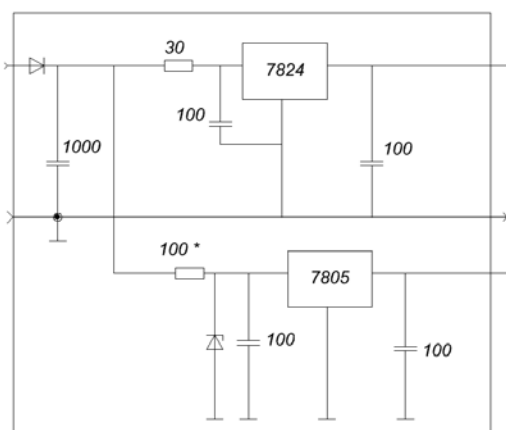

Fig. 5. Power supply circuit

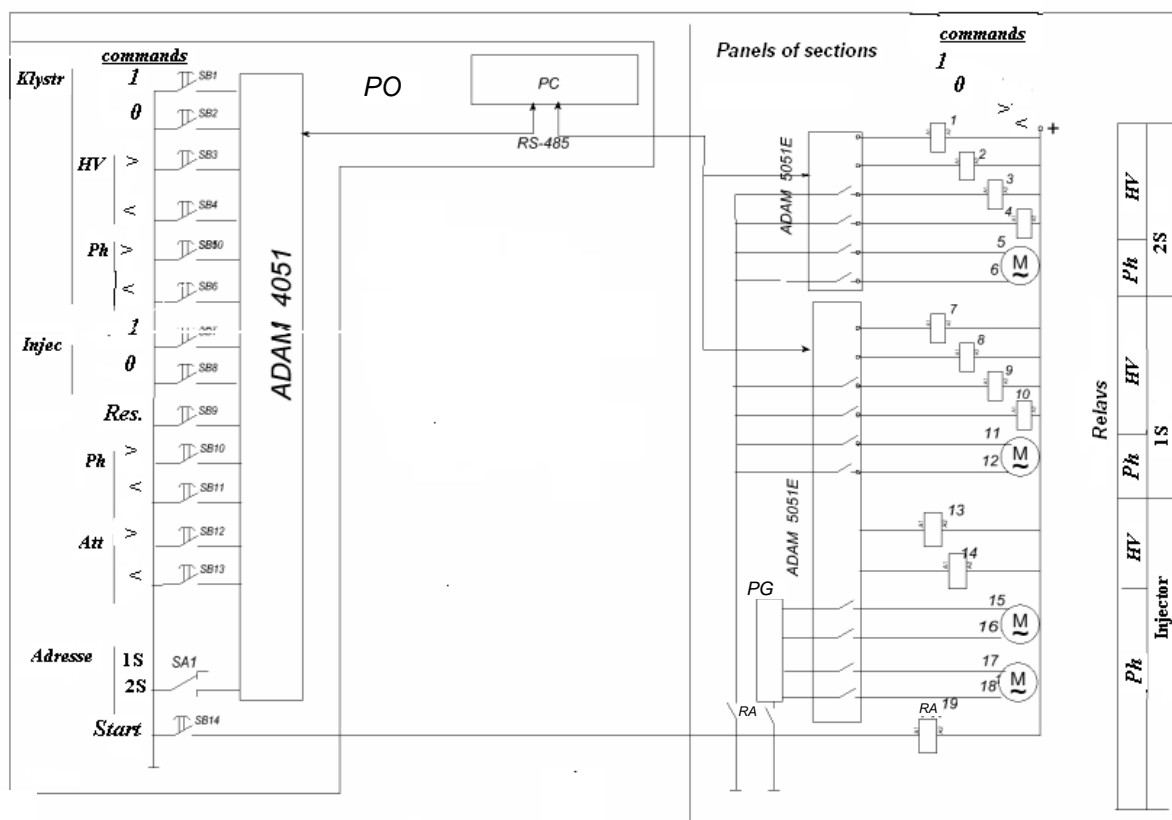

Fig. 6. The second variant RC of linac-60: 1S, 2S – the section; HV – high voltage; Ph – the phase; Att – the amplitude; G – >; L – <; SB, SA – the button; PO – the operator control panel; PG – pulse generator; RA – relay; M – motor

The analysis of the phasing algorithm shows that it consists of the operations of the address selection, subject to control, command of object parameter direction control and command of self-regulation, viz. of the preparatory and executive commands. If this principle is extended to other subjects of the remote control, you can still try to design a remote control by using the ADAM controllers. In doing so, the hold time of controllers by command preparatory part will be negligibly small as compared to the process of the regulation itself and will not significantly affect its basic function – locking. Then, as an encoder you can choose ADAM-5051 and load it with the above-mentioned set of controls including algorithm preparatory part of remote control (Fig. 6); and the executive part put on a separate link. Here, communication with the computer is provided for the organization of fault diagnosis linac.

REFERENCES

1. Yu.I. Akchurin, V.A. Momot, M.V. Ivachnenko, et al. Control system of Storage Ring Nestor Linac // *Problems of Atomic Science and Technology. Series «Nuclear Physics Investigations»*. 2007, №5 (48), p. 196-199.
2. Yu.I. Akchurin, V.N. Boriskin, M.V. Ivachnenko, et al. Linac failure diagnostic // *Problems of Atomic Science and Technology. Series «Nuclear Physics Investigations»*. 1999, №4, p. 40.
3. Yu.I. Akchurin, V.N. Boriskin, V.A. Popenko, et al. Structure control of the sections LEA-2000 // *Thesis proc. of XI All-Union seminar on linac*. Kharkov, 1989, p. 61-62.

4. N.I. Aizatskiy, Yu.I. Akchurin, V.N. Boriskin, et al. Control system for a linear resonance accelerator of intense electron beams // *Nucl. Instr. and Meth. in Phys. Res.* 1994, v. A352, p. 61-62.
5. Yu.I. Akchurin, V.N. Boriskin, M.V. Ivachnenko, et al. Control system of electron Linac LUE-40 // *Problems of Atomic Science and Technology. Series «Nuclear Physics Investigations»*. 2006, № 2, p. 115-116.

Article received 09.10.2013

ВАРИАНТЫ ДИСТАНЦИОННОГО УПРАВЛЕНИЯ ИНЖЕКТОРОМ НЕСТОР

Ю.И. Акчурин, М.В. Ивахненко, Е.И. Орлова

Рассматриваются два варианта схемы дистанционного управления ускорителем ЛУЭ-60 как инжектором накопителя НЕСТОР. Первый – автономная схема, построенная на дешифраторах 155ИДЗ. Во втором варианте для шифратора предлагается использовать ADAM-4051, а дешифраторами могут служить контроллеры АДАМ-5051Е, на которых уже построена схема местного управления и автоблокировки ускорителя. Наличие контроллеров, кроме того, позволит автоматизировать процесс диагностики неисправности ЛУЭ.

ВАРІАНТИ ДИСТАНЦІЙНОГО КЕРУВАННЯ ІНЖЕКТОРОМ НЕСТОР

Ю.І. Акчурін, М.В. Ивахненко, О.І. Орлова

Розглядаються два варіанти схеми дистанційного керування прискорювачем ЛПЕ-60 як інжектором накопичувача НЕСТОР. Перший – автономна схема, яка побудована на дешифраторах 155ІДЗ. У другому варіанті пропонується використати ADAM-4051 як шифратор, а дешифраторами можуть стати контролери ADAM-5051Е, на котрих збудована схема місцевого керування й автоблокування прискорювача. Наявність контролерів, зокрема, дозволить автоматизувати процес діагностування несправності ЛПЕ.