

SINGLE-MODE CAVITIES AT FREQUENCIES OF 172 AND 178 MHz

*V.N. Volkov, A.A. Bushuev, N.G. Fomin, E.I. Gorniker, E.K. Kenjebulatov,
V.N. Korchuganov, S.A. Krutihin, G.Ya. Kurkin, I.G. Makarov, N.V. Mityanina,
V.M. Petrov, I.K. Sedlyarov, A.G. Tribendis
Budker INP, 630090, Lavrentev Ave., 11, Novosibirsk, Russia*

In the report presented here the projects of two accelerating cavities with strong damping of higher modes (HOM) with special vacuum loads are presented. The designs of the cavities and loads are described. The design parameters of cavities, their spectra of higher modes and calculation results of the beam phase motion stability are given for the VEPP-2000 and NANO HANA Projects.

PACS numbers: 29.20.Dh, 42.60.Da

1 INTRODUCTION

An important problem in modern storage rings is an increase in stored currents. One of the restrictions is the occurrence of instabilities caused by the beam interaction with higher modes of the cavity. In the report presented here at the examples of two cavities, some versions of suppressing higher modes with special vacuum loads, which are the components of the cavity itself, are considered.

2 SINGLE-MODE CAVITY OF VEPP-2000

For carrying out experiments in the energy range from 1400 to 2000 MeV, at INP, it was decided to upgrade the VEPP-2M collider. A rather low particle beam energy pose some certain problem for providing the stability of the phase motion of bunches. The project of single-mode accelerating cavity with a strong damping of higher modes for elevating the threshold of occurrence of the beam coherent instability is developed.

Fig. 1 shows the sketch of the cavity.

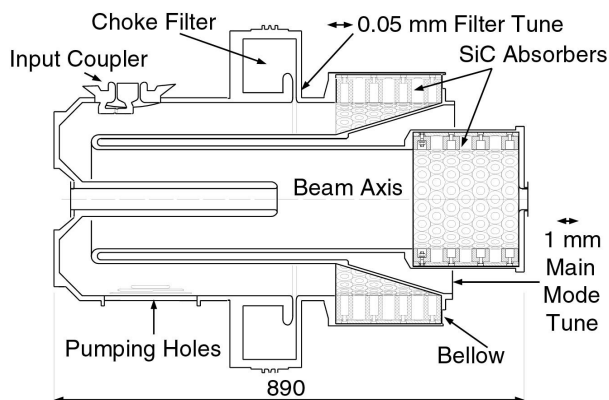

Fig. 1. Cavity of the VEPP-2000 storage ring.

Damping of higher modes in the cavity is achieved by two cylindrical absorbing loads (SiC Absorbers), the coaxial and wave loads.

The coaxial load is well matched with TEM wave ($KCBH < 1.5$) and it provides the damping of high modes in the frequency range up to 3500 MHz. The locking filter (Choke filter) located in front of this load tuned to the frequency of the operating mode prevents additional damping of the mode.

The wave load, which is located in the vacuum

chamber of the cavity of 187 mm in diameter, loads the higher modes whose frequencies are higher than the waveguide critical frequency (1235 MHz). The waveguide is beyond the limit of the wave related to the operating mode field, therefore the load does not influence on the wave.

Loads are compiled of separate elements in the form of cups made of the conducting ceramics KT-30. These elements are screwed to the water-cooled wall of the cylinder. Fig. 2 shows the sketch of the load ceramic elements.

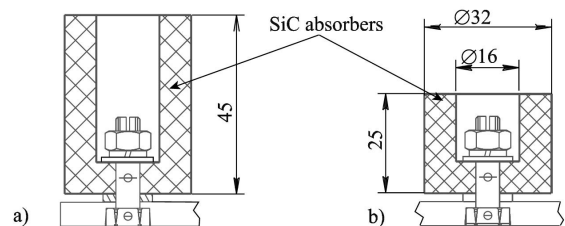

Fig. 2. Load absorbing elements of KT-30 ceramics: a) for the coaxial load, b) for the wave load.

Table 1. Properties of KT-30 ceramics.

Volume conductivity, 1/Ohm m	1.67
Dissipation factor $\text{tg}\delta$, at $f = 10$ GHz	no lower than 0.2
Dielectric constant at $f = 10$ GHz	15
Thermal conductivity, W/(m K)	5

Table 2. RF parameters of the VEPP-2000 cavity at the operating frequency.

Frequency, MHz	172.099
Tune range, kHz	32
Quality factor	8800.7
Accelerating voltage amplitude, kV	120
Transit time factor	.9898
Shunt impedance, kOhm	246.99
Maximum surface temperature	60
Total thermal losses, kW	29.25

Table 1 shows the properties of the KT-30 conducting ceramics. RF parameters of single-mode cavity are given in Table 2.

With the use of the CLANS program we have carried out the calculations of the coupling impedance of the higher modes within the range to 3500 MHz. Calculation results are given in Fig. 3.

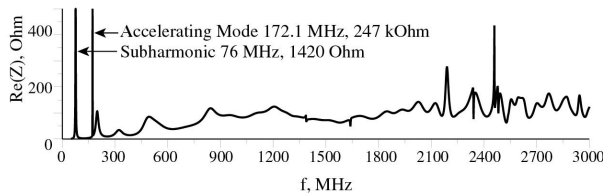

Fig. 3. Coupling impedance of the VEPP-2000 cavity higher modes (real part).

The cavity has low (200-300 Ohm) impedance for coupling higher modes (except for modes 76 MHz and 2460 MHz). The calculations of the cavity are given in more detail in [3]. As the calculations (done with MBI program [4]) show, these impedance values for the cavity higher modes provide the stable phase motion of bunches in the VEPP-2000 storage ring even with a two-fold increase in the beam current (2x200 mA).

3 SINGLE-MODE CAVITY FOR NANO HANA PROJECT

By the order of the Japanese Firm Kawasaki Heavy Industries Ltd, the project of the NANO HANA storage ring - a dedicated SR Source with a large beam current at rather low energy of beam particles (0.5-2 GeV) is being developed at BINP, Novosibirsk. At the storage ring, two single-mode cavities are installed; one of which is shown in Fig. 4. The cavities have one joint pumping unit located between the cavities (Pumping Group).

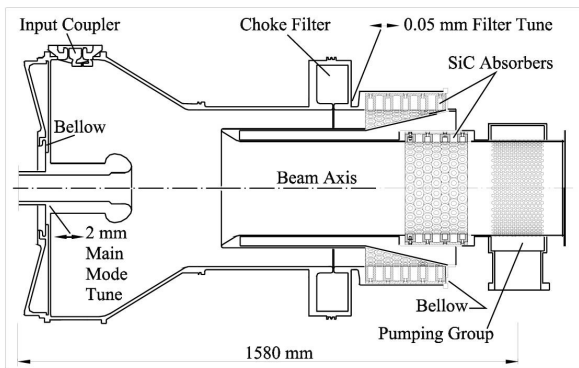

Fig. 4. Single-mode cavity for NANO HANA.

The principle of damping the higher modes is the same as that for the VEPP-2000 cavity, with two cylindrical absorbing loads (SiC Absorbers): the coaxial and wave loads. The vacuum loads of the higher modes (SiC Absorbers) and locking filter for the operating frequency (Choke Filter) have the same basic design as that described above.

Parameters of the single-mode cavity at a frequency of accelerating mode are given in Table 3.

Table 3. Parameters of the single-mode accelerating cavity for NANO HANA

Frequency, MHz	178.50
Tuning range, MHz	0.37
Quality factor	25379.0
Transit time factor	0.9266
Characteristic impedance*, Ohm	103.6
Shunt impedance*, MOhm	2.62853
Accelerating voltage, kV	600.0
Power of RF losses, kW	67.8

*Taking into account the Transit time factor.

Fig. 5 shows the impedance real part of coupling cavity HOM calculated by the CLANS program [2].

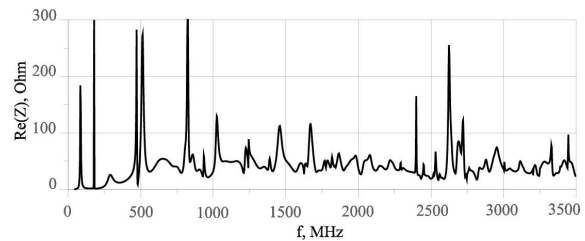

Fig. 5. Impedance of coupling higher modes of NANO HANA cavity (real part).

Coupling impedance of the cavity higher modes has an order of 200-300 Ohm in the range from 60 to 3500 MHz except for the frequency of the mode 822 MHz having the impedance of 533 Ohm.

The use of two such cavities in the storage ring enables one to get the stable multibunch phase motion with use of the feed back circuit. The amplifier output power in the feedback circuit is ~400 W.

4 CONCLUSION

As calculations have shown, the design and dimensions chosen for the single-mode cavities provide a rather strong suppression of the cavity higher modes and provide the stability of given currents for the VEPP-2000 and NANO HANA storage rings. In the design of loads, we use the conducting ceramics elements of the serial production in Russia. VEPP-2000 cavity is fabricated now in BINP.

REFERENCES

1. Yo.M.Shatunov et al. Project of a New Electron-Positron Collider VEPP-2000 // *Proc. of 7th EPAC*, 2000.
2. D.G.Myakishev, Preprint Budker INP 2000-55, Novosibirsk, 2000.
3. V.N.Volkov et al. VEPP-2000 Single Mode Cavity // *Proc. of 7th EPAC*, 2000.
4. N.V.Mityanina, Preprint Budker INP 99-46, Novosibirsk, 1999.
5. V.Korchuganov et al. // *Nucl. Instr. and Meth.* 2000, A448, p. 27-31.