

READOUT ELECTRONICS FOR MULTICHANNEL DETECTORS

V.I. Kulibaba, N.I. Maslov, S.V. Naumov, V.D. Ovchinnik, I.M. Prokhorets
NSC KIPT, Kharkov, Ukraine
naumov@kipt.kharkov.ua

Readout electronics based on the 128-channel chip “Viking” (IDE AS inc., Norway) is considered. The chip “Viking” integrates 128 low noise charge-sensitive preamplifiers with tunable CR-(RC)² shapers, analog memory and multiplexed readout to one output. All modules of readout electronics were designed and produced in KIPT taking into account the published recommendations of IDE AS inc.

PACS number: 29.40.Wk

1 INTRODUCTION

There is a big difficulty or even an impossibility to design and implement conventional readout systems based on discrete components as a number of readout channels of a detector grows (i.e. microstrip detectors [1], diode matrixes [2] etc). For example, to build readout electronics for the 128-channel detector one should apply 128 charge sensitive amplifiers, 128 shapers, 128-channel ADC and a lot of additional elements. A size and a power consumption of such a system will surely make it unusable in a real practice. And it is absolutely impossible to design a discrete readout system for the 768-strip detector. That is the reason why integrated electronics has been actively developed since the end of 80's. The integrated readout electronics main features are low power consumption, small outlines, low noise (200 e⁻ or less). These features allow to place readout electronics near to the detector, simplify a cooling, make possible to reach a signal-to-noise ratio 60 or more.

2 MULTICHANNEL READOUT CHIP

We have chosen the Viking VA2 chip (IDE AS company, Norway) to design our readout system. This chip has such main characteristics:

- 128 readout channels of analog signals from a detector, each of them includes charge sensitive preamplifier, CR-(RC)² shaper and analog memory;
- integrated multiplexer used to dispatch all 128 analog signal to one output in a sequential readout mode;
- built-in test and control circuits, which include input multiplexer and shift-register to distribute test pulses through the chip channels;
- externally adjustable peaking time in a range from 0.5 to 2 μs;
- noise performance 60e⁻ + 11e⁻*pF for a peaking time of 2 μs;
- dynamic range no less than 4 MIP for bipolar signals and 8 MIP for a single polarity;
- maximal readout rate up to 10 MHz;
- contact pads have a pitch of 50 μm, that meets demands of the most popular detector bonding;
- available as unpacked dices, outline dimensions 6×4 mm.

The structure of one readout channel of VA2 is shown in Fig. 1. This type of readout designs is used often to build as well as sophisticated multichannel and

simple single channel preamplifiers.

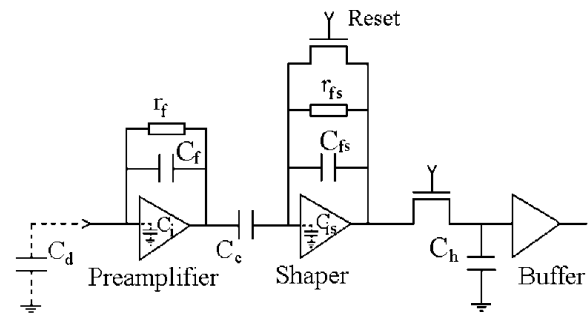

Fig. 1. Structure of one analog readout channel of VA2 chip.

It integrates the charge sensitive preamplifier, the voltage controlled CR-(RC)² shaper, the analog memory with the externally controlled track-n-hold circuitry. This readout system has a big flexibility, that allows to adjust all parameters when a maximum of speed or a minimum of noise is required in the experiment. 128 bit shift register controls the sequential readout process. The structure of overall chip is shown in Fig. 2.

The next describes the work of the chip. 128 input pads are bonded to corresponding detector pads, from where the analog charge signal comes. After a physical event (a particle detection) each channel collects some charge. Then after the peak of the pulse in the shaper has been reached, an external signal activates the analog memory of the chip, that fixes the peak voltage. Shifting a one bit through the control shift register multiplexes all analog channels outputs sequentially to one output of the chip, i.e. multiplexed readout is achieved. The output signal can be processed by a computer to obtain a spectrum. The chip can also work in a single channel mode. In this mode an arbitrary channel is selected through the control shift register, the analog memory circuits are disabled and it means the chip work as a simple pair of preamplifier-shapers. This mode is very useful for testing purposes and allows to estimate a pure noise performance of the readout system without an influence of high frequency digital circuits, which are used in a high speed sequential multiplexed readout.

3 READOUT ELECTRONICS

Our readout electronics system comprises hybrid module, repeater module and sequencer (Fig. 3). Hybrid module is designed on a printed circuit board with nick-

el coated copper contact pads, that gives a possibility to bond aluminum or gold conductors with help of ultra-

sonic welding. The Viking VA2 chip is fixed on the board by a special glue.

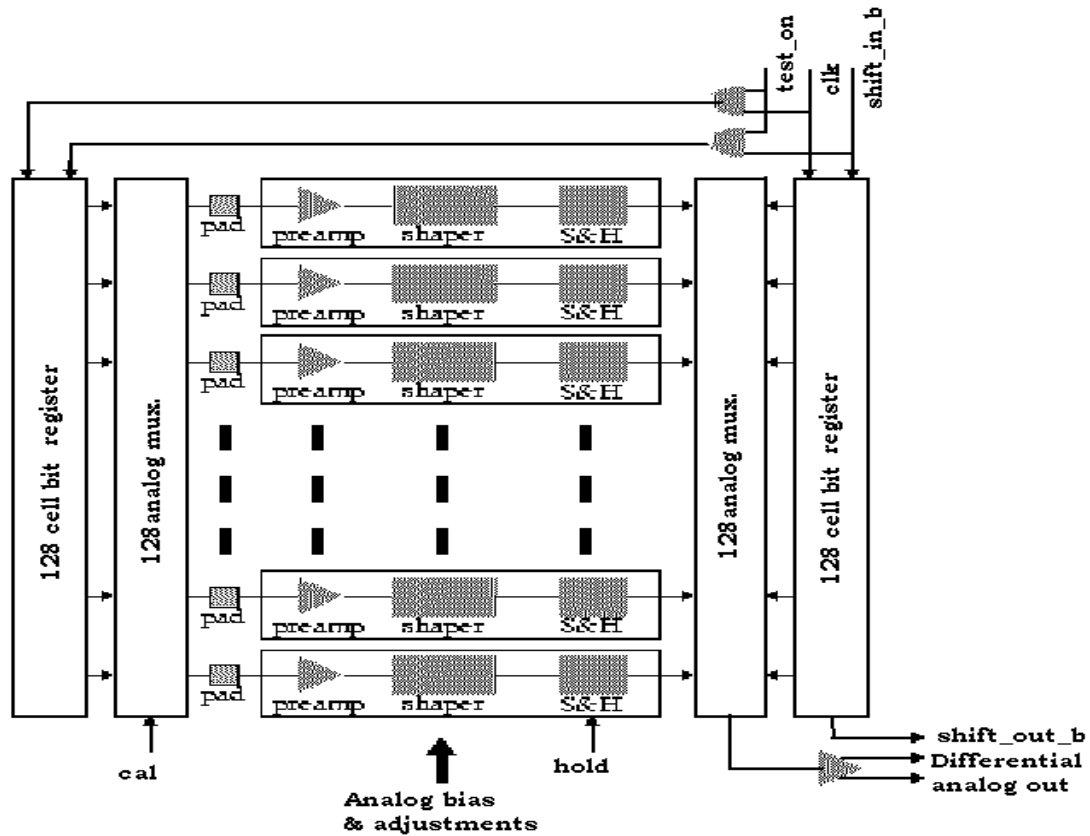

Fig. 2. Structure of overall VA2 chip.

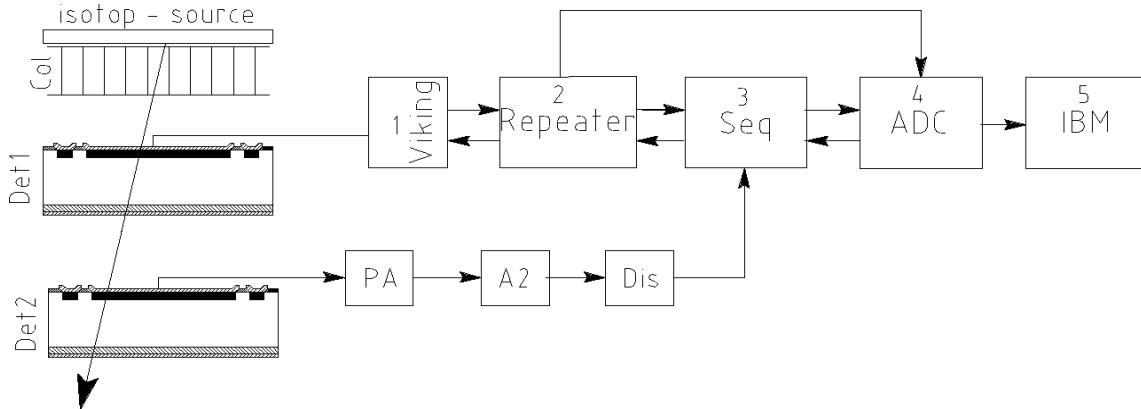

Fig. 3. Experimental setup.

The board can provide a connection to the chip through a special flat film microcable or through traditional microwires, which are bonded to pads on the board by means of ultrasonic welding. The main task of this printed circuit board are to provide an exchange of digital and analog signals between VA2 chip and the repeater module, to filter power supplies of the chip, to set necessary operation mode of the chip through the control circuits on the board. The form-factor of the PCB allows to fix detectors in the vicinity of the readout chip. The repeater module and the sequencer control the readout process. When an external trigger signal is active the sequencer generates a sequence of digital TTL signals to control the VA2 chip and the ADC. The cur-

rent setup uses the trigger signal from a scintillation detector. The sequencer also allows to work with the chip in a manual channel selection, when the chip is set in a single channel mode as described above. The repeater converts digital TTL signals of the sequencer to signals compatible with VA2 CMOS logic levels, amplifies output analog signals from VA2 chip, stabilizes power supplies for the chip. It also allows smooth adjusting a peaking time of the shaper inside the Viking chip.

The analog signal from the repeater module comes to an input of a fast ADC with built-in FIFO memory. The size of the memory should be enough to keep all data from 128 channels of VA2chip. In this setup there are two types of ADC available for use – the CAMAC

ADC or the computer built-in ADC.

A maximal possible readout frequency for this system is 1 MHz, that gives a reaction time less than 130 μ s. The time diagram of the readout process is shown in Fig. 4.

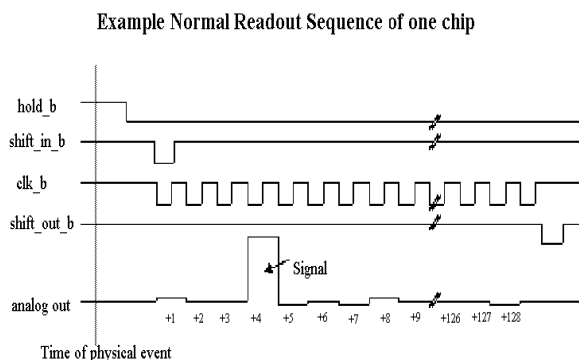

Fig. 4. Example of sequential readout of one chip.

4 RESULTS

We have studied the system to evaluate its operation and quality. Noise performance of readout system was investigated and spectral distributions were obtained to find signal-to-noise ratio, that is an universal parameter of the detection system. All spectra were obtained on a 128 strip single-side detector from isotope sources of gamma-quanta ^{241}Am for the single channel mode and electrons ^{90}Sr for the total 128 strip readout (multichannel mode). Noise performance of the system has been preliminary calculated using formulas for the noise sources definition in the readout electronics [3]. The total noise (e^- r.m.s) is $ENC = \sqrt{ENC_a^2 + ENC_l^2 + ENC_r^2}$, where ENC_a is the amplifier noise, ENC_l is the noise of the leakage current I_l of the strip, ENC_r is the noise of the parallel combination R_p of the feedback resistor of the amplifier and the biasing resistor of the detector. Considering real parameters of the detector to be 1 nA for the leakage current, 5 pF for the strip capacitance and 18 MOhm for the R_p resistor combination, we can calculate the noise as $ENC=320 e^-$ r.m.s, that gives the signal-to-noise ratio value 70 for MIP equivalent charge (about 22500 e^-).

These spectra are shown in Fig. 5. The signal-to-noise ratio for these spectra is more than 60 and fits well our previous calculations. That signal-to-noise ratio implies a good possibility to use such systems in a wide range of accurate experiments or technical engineering and designs.

5 CONCLUSION

The system of readout electronics based on the integrated chip Viking VA2 was considered. These chips allow designers to build high-quality readout systems with small quantities of components for multichannel detectors. As an example of such system readout electronics for microstrip detector was considered. It is quite possible to design readout systems based on Viking chips for use with other types of multichannel detectors, such as photodiode matrixes. IDE AS company pro-

duces families of similar integrated multichannel readout chips with integrated triggering circuits – self-triggering chips TA and XA. They allow to design high-speed multichannel readout systems for detectors without external triggering components, also they give a possibility for multichannel or microstrip detectors to operate with gamma-quanta radiation sources in a real multichannel mode of detection, that is not possible when using ordinary externally triggered integrated readout electronics for these detectors, such as VA chips series.

Fig. 5. Example of spectra of gamma-quanta and electrons from isotope sources ^{241}Am and ^{90}Sr .

REFERENCES

- 1.A.P. de Haas, P.Kuijjer, V.I.Kulibaba, N.I.Maslov, V.L.Perevertailo, V.D.Ovchinnik, S.M.Potin, A.F.Starodubtsev. Characteristics and radiation tolerance of a double-sided microstrip detector with polysilicon biasing resistors // *Problems of Atomic Science and Technology. Issue: Nuclear-Physics Research* (36). 2000, v. 2, p. 26-33.
- 2.G.Bochek, V.Kulibaba, N.Maslov, S.Naumov, A.Starodubtsev. Silicon pad detectors for a simple tracking system and multiplicity detectors creation // *Problems of Atomic Science and Technology. Issue: Nuclear-Physics Research* (37). 2001, v. 1, p. 36-39.
- 3.E.Nygård, P.Aspell, P.Jaron, P.Weilhammer, K.Yoshioka. *CMOS low noise amplifier for microstrip readout. Design and results.* CERN-PPE/90-142 October 1-st, 1990.