

**Ya. Mankuta,***PhD (Economics),*

ORCID 0000-0003-1623-5149,

e-mail: yana.mankuta@suem.edu.ua,

*PHEI «Rauf Ablyazov East European University», Cherkasy*

## **STRENGTHENING THE ECONOMIC INTERACTION OF INFORMATION AND COMMUNICATION TECHNOLOGIES IN THE INNOVATIVE DESIGN OF ACTIVITIES OF EXTRACURRICULAR EDUCATIONAL INSTITUTIONS USING ELECTRONIC EDUCATIONAL RESOURCES**

**Introduction.** The problem statement. Modern education system in Ukraine must overcome essential digital alterations to relate to global tendencies of digital evolution to cater for realizing any personal potential.

The increase of demands for the staff professional competence in HEIs forces to quickly adapt to information environment, being competent in various practical situations for applying electronic means of teaching, therefore evolving digital competence is quite important in theory and practice of professional training.

Teacher's proficiency is absolutely decisive for teaching at HEIs. According to official standards of quality in teaching modern universities must secure the development of teaching staff professional competence applying transparency for the staff personal evolution [1, p. 190].

In the National economic strategy for the period till 2030, educational and scientific matters are given key positions in several directions of economic development, including direction 8 "Informative and Communication Technologies", mainly in its part on introducing computer techniques into social infrastructure units and on promoting digital skills for population, and also in direction 20, "Quality of Life", in part of raising living standards of the Ukrainians in general [2].

Introducing modern informational and communicative technologies (further ICT) that improve processes of education and upbringing, secure accessibility and efficiency of education was approved in 2013 National Strategy of Education Development as its prior task [3]. Besides, the Concept for promoting digital economy and Ukrainian community actualizes the tasks for digitalization of education, including creating educational resources and digital platforms supported by interactive and multimedia content in general access, and instruments of automated main processes in educational establishments, working out and introducing innovative computer, multimedia and computer oriented education means and equipment to create digital educational environment [4].

To fully execute proficient functions in staff competence complex, digital competence was singled

out as an essential element and a key competence for digitalizing educational activities.

The main problem of digitalizing the education is insufficient level of staff digital competence. Old fashioned teaching methods, lacking digital competence standards, the relative system of improving proficiency in digital education for teaching staff and also low accessibility to digital techniques for all agents of the processes resulted in low level of teaching staff competence in all factions of state educational system [5].

Digital competences include skills of applying, filtering, evaluating, creating, projecting and expanding digital educational resources [6, p. 211]. Hence acquiring digital competences is signified as a part of basic demands and needs education system must ensure their acquisition by the students and the staff as well as development of digital infrastructure, electronic services and electronic educational resources (further EER) at HEIs.

Digital competence is based on applying digital techniques, means of communication, management, integration, evaluation, creation and transmission the information ethically and lawfully for taking active part in informational and educational community. Digital competence contains skills of working in digital information and communication environment, perceiving and critical measuring of the digital and media content, efficient and safe application of digital means to solve various professional tasks.

This need is as well deepened by corona virus pandemic consequences that affected the problem of studying digital techniques by teaching staff at universities to manage teaching in distance and mingled learning and its resource support through necessary education means.

It is educational transformations that are under way in teaching community that demand related competences of teaching staff that may be arranged within improvement promoting syllabi.

Under the documentary instructions on promoting qualification improvement for teaching and scientific staff approved by the Cabinet of Ministers of Ukraine

the main tasks are signified to enforce earlier obtained and/or to obtain new competences in the professional sphere or training considering the demands of the related professional standard, obtaining the experience for doing optional tasks and taking optional duties in occupation and/or professional activity, and/or in job position, creating and evolving digital, managing, communicative, media, inclusive, speaking competences [7]. Therefore, these documents enable organizing qualification improvement for teaching staff and scientific employees at private and corporate educational institutions by the establishers or entitled foundation bodies.

Hence, there emerges a need for new approaches and organization patterns of the teaching staff qualification improvement including institutional open educational systems (further OES) for professional enforcement with which teachers are trained in job positions, in working surroundings when the re-preparation goes alongside with managing processes of introducing ICT at HEIs.

Solving tasks of the teaching process with EER is grounded through goals of digital education that officially is treated as “combination of various components and most updated technologies as a result of digital platforms application, new information and educational techniques, progressive forms of academic activity and pro-active teaching as well as quite up to date educational content” [4].

Problems of creating and applying models and choice making methods for ICT to create and making EER projects for OES at HEIs within qualification improvement syllabi aimed at digital competence for teaching staff in digitalization of educational processes, active application of techniques of mingled and distance schooling in quarantine periods at HEIs.

Creating EER is aimed at securing modern standards for teaching, managing accessibility for all participants of the academic process to get excellent ICT learning content, irrespective of their habitat and form of education [8].

**Theoretical framework.** Ukraine’s scholar outlet is represented in writings by V Bykov, M. Leschenko, Yu. Zhuk, N. Morze, O. Spivakovsky, M. Zhaldak, S. Lytvynova, R. Hurevich, A. Hurzhiy etc. who are broadly dealing with problems of ICT efficient application in academic learning, that regard evolving professional and digital competence, applying information techniques for learning, training teachers to professionally activate through digital techniques.

Ukrainian scholars, V. Bykov, M. Leshchenko, A. Yatsishin [9-12] are working out problems of open education, educational environment, means and methods of open education, open teaching systems, digital transformation in academic learning, introducing digital techniques.

Collective monographic edition [6] represents modern paradigms for working out teacher’s personal informational and digital competence, signifies the

model, factors and specific features of this competence in the system of teaching postgraduate training courses.

Therefore, universities should be transformed into Smart-universities that are conceptually based on informative and educational environment (IEE) which contains electronic content and interaction techniques of all participants of the academic process as it is regarded in publications by O. Buinytska and B. Hrytseliak [13].

In the article by S. Karplyuk [14] the notion of digitalization is regarded, the task and possibilities of digitalized education activity in modern HEIs are signified, with the system of digital competence including information resources, telecommunication and management.

Education system influenced by digital techniques and main notions for electronic teaching paradigm are regarded by V. Sedov considering that recent needs for the specialists are those in persons who are able to create educational routes and guide students along those routes, to work out on-line courses, education on-line platforms [15].

Yet foreign and Ukrainian scholars differently interpret competences connected with ICT, through applying various terms to signify similar skills and abilities like information and communicative competence, electronic competence, digital literacy, etc.

Foreign researchers regard digital competence as an ability to apply digital resources and information techniques, to perceive and critically evaluate digital resources and content, to exercise efficient communication [16], knowledge, skills, frameworks, necessary for the ICT and digital media to do tasks, problem solutions, information management, cooperation, communication, education [17].

Admitting digital competence as most upgraded concept to describe technological skills, Ukrainian scholars N. Morze, S. Vasylenko, M. Gladun define digital competence of a university lecturer (information literacy, communication and cooperation, creating digital content, safety and problem solution) [18].

O. Myroshnychenko gives definition to digital competence as an integrated ability to timely, critically and safely in professional area to choose, create and change digital resources, exercise their management, secure them and spread, apply them to teaching that increases possibilities for students and their digital competence. The author suggests the structure of digital competence: information and search competence, on-line communicative competence, safety and technical competence [19].

Improvement of teaching qualification in jobs, within framework of project for introducing mingled education, making EER projects for open systems in qualification enforcement are main matters in the article by O. Shcherbyna [20; 21].

Education environment at HEI in which learning and education management are realized is represented by EER that is ruled through skills and abilities of digital competence.

EER sense, content and typology are regarded in publications by V. Bykov, V. Lapinsky [22]. As the author states, EER or subject and information resources for education purposes are means for teaching in electronic models that are presented in teaching systems by electronic information sources [10, p. 417].

However, problems of making EER projects with ICT for qualification enforcement as a demand for the personnel employment in education programs require further research.

The research goal is to signify instruments and methods for ICT to create models in making projects, creating and applying EER in education that is solved within teaching staff enforcement programs.

**Methodology.** To obtain the settled goal, the method of system analysis was employed that enabled to single out the scholar investigation strategy. Therefore, structural and functional approach is applied within the method that is defined through decomposition of structure elements in open education environment as integrate and complex system and through presenting its components, and also the process approach to signify and describe EER processes preparation.

Modeling method is applied to build up a functional model in the processes of creating computer oriented environment in making EER projects. The method presupposes CASE technologies application based on application of instrumental means for structure analysis and modeling. According to the created project model and EER creation for the open education environment, the Rauf Ablyazov Eastern European University (Cherkasy, Ukraine) had worked out the integration project to introduce academic content delivered to be employed for teaching in the mingled and distance education techniques.

**Results.** One of prolific trends in reforming higher education is creating electronic courses in subject learning and introducing them into academic process. As electronic training system is presented at HEIs, students can be taught in decent hours and deliver their personal learning route.

E-learning (or electronic learning) is system of electronic education synonymous to such terms as electronic education, distance education, ICT training, network training, virtual ICT learning [23, p. 46].

E-learning can be classified according to means of obtaining learning content: synchronous (webinars, video conferences, document processing) and asynchronous learning (Email, file exchange, podcast, open on line courses). Within E-learning paradigm, trends and approaches were singled out, such as open learning resources (resource oriented education), education management system and mobile learning created to support distance learning that now is well applied in hybrid learning, community open on line courses, inverted class etc. [15, p. 75-76].

E-learning instruments include:

– student's personal room that is a personalized virtual working environment with all information and

access to resources and supplements employed in learning;

– depository of full text teaching content needed for keeping, searching and giving regular access to various learning instruments;

– interactive testing system that serves to monitor learning through testing;

– webinar service to exercise distance learning and consulting;

– repository of learning video content.

Hence, e-learning is a teaching paradigm based on open education resources, decentralized education activity and employed information technologies such as on line courses, digital resources, web-services, mobile applications.

Open education resources are digital education content for staff and students in the open environment that are spread with open license. For example, lecturing notes, video courses, scientific journals and publications [15, p. 76].

According to the degree of investigation area, to the form of teaching content, teaching methods, presence/absence of possibility of academic communication and ways of monitoring learning progress, open learning courses that are divided into two groups:

– separate digital learning and scholar resources in open access (manuals, textbooks, lecture notes, audio and video content, drills, tests, practical courses, scientific articles, monographic publications, databases);

– community open online courses (COOC) located on present online learning platforms (Universarium, Uniweb, Coursera, edX, Udacity).

Education programs, introduced in Ukrainian HEIs, demand appropriate methodology in learning that needs to be constantly revised, renewed and actualized. Usual time norms for self-preparatory learning imply 2/3 of class hours to promote quality learning as it is impossible to do without EER.

EER is normally defined as means of digital teaching or teaching instruments located in the information tele communication systems that are presented through electronic technical means and are applied in academic activity [8].

According to functional attributes, EER are divided into electronic editions (electronic version, copy, analogous edition) of printed book, e-book, e-practice tests, e-reading books, e-lecturing, e-manual, e-game resource); e-references (e-reference editions, e-encyclopedia, e-dictionary); e-practices (collection of virtual laboratory practices, e-recommendations in methods, e-workbooks) [8].

Most popular in the system of qualification enforcement is hybrid learning that is education model that combines digital and traditional modes of teaching. In this model students combine class learning and on-line studies.

Distance learning (DL) practiced in most Ukrainian universities and in the Rauf Ablyazov Eastern European University (Cherkasy, Ukraine) (further

RAEU) employed as a technology based on the open education principles widely applying computer programs of various aims and creates through modern tele communications information education environment for content learning and communication.

RAEU employs specialized software, system of distance learning (SDL) “Prometheus” that supports: obtaining and evaluating knowledge in the I-net environment, in corporate and local networks, sharing access to education resources and system management means; registering participants’ activities in the learning complex, dividing intercommunication among students, managing learning process. Electronic components of the syllabic complexes are located in single information and education environment of the RAEU on the SDL “Prometheus” basis. The system is presented through 2500 electronic education and methodology complexes, about 900 subjects that employ testing system, database constantly renovating [24].

Local normative documents regulating qualification enforcement at the RAEU should mention ways and types of EER that are initially chosen and later, appropriately introduced, and what preparations should be made, whereas next stage should be staff training in creating and employing the EER chosen. According to the results of the training, EER for subjects taught by the staff are created and located in the virtual environment.

Open system concept for staff qualification enforcement is based on main principles, models and methodical system of teaching that presuppose scaling of academic activities, collective work of teaching in small groups, teachers’ independent work with distance learning techniques [25]. OES that is SDL “Prometheus” at the RAEU, is presented as both the main studying object and means of staff teaching and monitoring the ICT in the University academic studies.

Methodology basis for creating and employing EER in teaching personal subjects should be the combination of two interconnected components: technological (teaching the staff to necessary ICT) and applied (applying ICT in teaching personal subjects) [25].

Tendencies to increasing importance of staff qualification improvement in OES, combination of various forms of learning through expanded employment of ICT resulted in emerging computer orientated environment for making EER projects that is a directed process for obtaining knowledge, skills and abilities in the integrated class and extra class activities of students and staff based on mutual complementation of technologies of traditional, electronic, distance and mobile learning.

Education process model should contain the stage of building up and adaptive supporting of the relevant academic course that can be regarded as a personal web environment for learning. In it, to promote the learning process electronic teaching and methodology content should be located, exactly: distance courses of the

teaching modules, e-books, electronic information content, test works.

Staff quality enforcement at the University can be also regarded as corporate education. Both corporative learning and progress management deal with knowledge exchange and founding communities for spreading knowledge. DL in the context of sustained learning and progress management (PM) are solving similar tasks: learning, ability to solve working tasks, to take efficient decisions and positively affect the surrounding community. PM is of dynamic nature, it supplies with actual knowledge, though with time, this knowledge appears to be not quite well shaped and cannot be applied for learning courses. Instead, DL is focused on verified and well structures knowledge through special syllabi that are often quite static. The drawback here is that such knowledge can lose its novelty characteristic for PM tasks. Hence, the architecture of classical SDLs cannot cater for the demands of progress management processes [26].

To realize sustained learning for the staff oriented on digital competence, the concept is appropriate to be applied: PM is regarded as a repository and learning process is the one to apply this repository. The latter secures safety and search of objects and also their being uploaded by the users.

The main sense and material for the SDL is digital learning content, any academic stuff represented through digital data or I-net references to such stuff. In connection with specific teaching tasks for DL on presenting education content, special classes of systems became popular that serve to manage learning content and teaching processes: CMS (courseware management systems), LMS (learning management systems), LCMS (learning content management systems), SDL – systems of distance learning, the term is appropriate for systems in Ukraine [26].

Results of comparing LMS and LCMS obtained by Brandon-Hall Research Group [27] testify that as environment to support combined learning LMS are better for application. Most popular LMS systems are Moodle, OPEN EDX, Blackboard, Claroline, Dokeos, ATutor, ILIAS, OLAT etc.

In the context of general project for introducing ICT in the University, in various types of EER ICT are considered as its separate stages. Such projects are quite complex in arrangement if consider their participants and complexity of tasks to be solved [25].

Among recent methods for making projects, CASE technologies are most efficient as those based on instrumental means of structure analysis and modeling. Irrespective of either the model exists, or is being under project there are some models of structure analysis that can fully describe the system. Most popular among them are SADT, models and related functional diagrams DFD, diagrams for ERD data streams, diagrams “sense-connection”. To solve the tasks of complex systems modeling, there was founded family of standards and methodology ICAM that consists of IDEF0, IDEF1-



IDEF14. In practice, SADT is structured with IDEFO notation suggested by Douglas Ross [28].

For functional modeling in processes of creating computer oriented environment while making EER projects for staff quality enforcement, IDEFO model is chosen. This methodology is noted for its focus on hierarchy of objects. IDEFO standard regards logical relations of stages but not their successive order and is represented as a set of modules connected with activity arrows (ICOM). Basic model description is presented in detail as much as the level needed through decomposition diagrams reproduced in notations IDEF0, IDEF3 or DFD [21]. Upper level diagram describes general process of creating and teaching academic course with EER applying. Special model for making EER project for open learning environment is given through functions of investigating the current state

of the environment, creating LMS programming modules, working out EER, as well as learning process proper and qualification improvement (see figure).

Process “Investigation of current situation in education environment” is described through functions of checking teachers’ competence level at ICT, analyzing university IT-infrastructure, investigating university network and network resources and also further dealing with proposals for improving education environment. Initially the model obtains information about teachers’ competence, education environment infrastructure, information system currently applied and experience of other education institutions. Finally, the model forms analytical report on HEI infrastructure, local network analysis results, staff ICT competence report and proposals on its improvement.

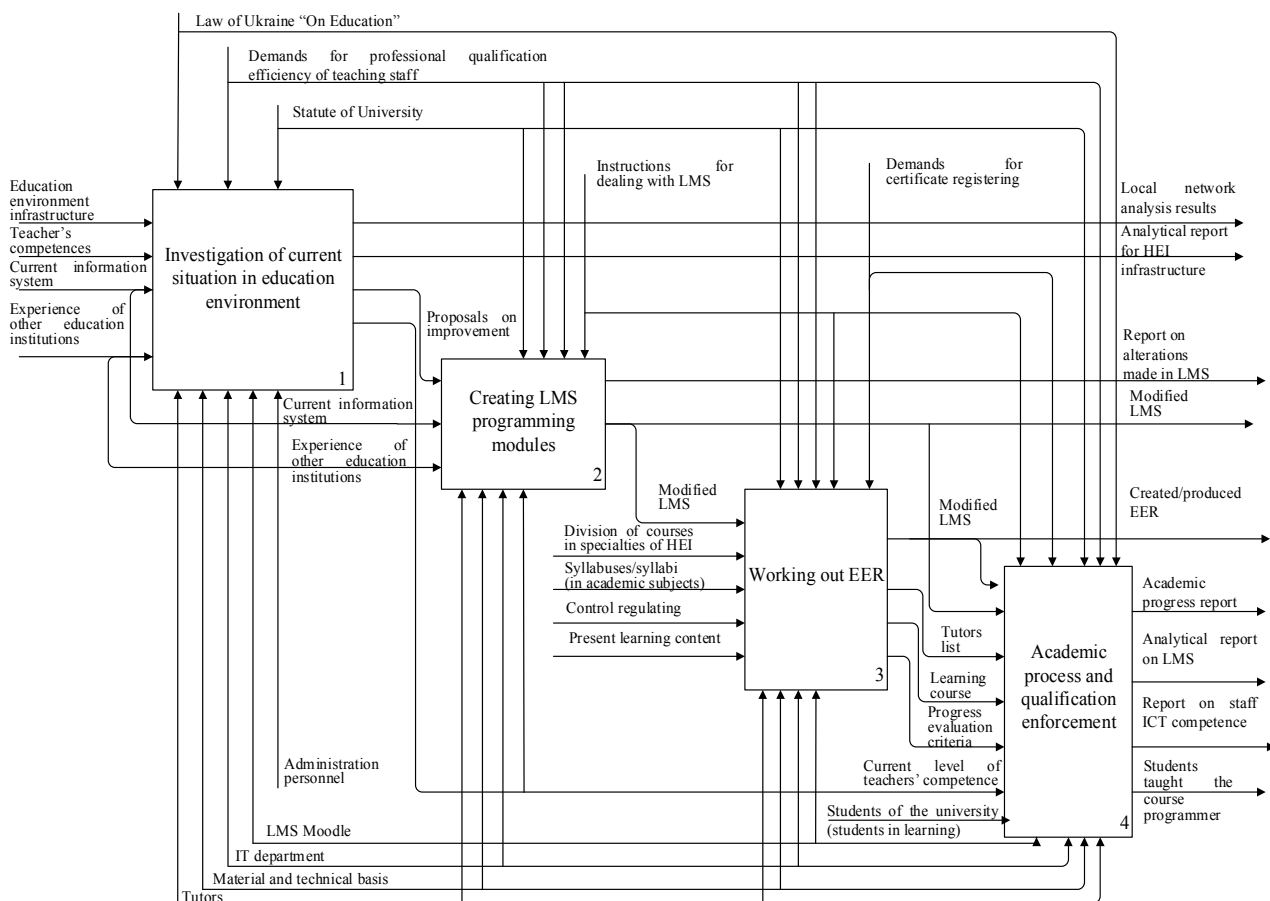

Figure. Decomposition diagram "Designing EER for open educational environment"

Function “Creating LMS programming modules” can be divided into sections: making projects for subsystems to identify the users, projects for subsystems of access to courses, fixing means of creating electronic learning resources and also means of monitoring and control. Initial positions show the model with the proposals for improvement that are formed in the previous functional block and with data for current information system and experience from other institutions.

Function of creating learning content by teaching staff of the institution can be divided into parts that are included as types of work into the diagram of decomposition “Working out EER”: teachers’ corrections of the learning platforms, preparing course discipline structure, creating learning content, control and test tasks. The initial stage for the model is modified LMS, syllabuses in academic subjects, present learning content, control regulating, division of courses in specialties of HEI. Final stages present tutors list, the list

of ready-made EER, progress evaluation criteria and completed electronic learning courses.

Functional block for academic process promotion and staff qualification enforcement contains the following elements: users' initial activity in the system, their progress at perceiving learning content, doing current testing tasks, final tests in course subjects and evaluation of competence level at ICT for tutors. This model starts with introduced academic course, tutors list, list of produced EER, progress evaluation criteria, current level of staff competence, student audience and modified LMS. The model final stage presents academic progress report, list of students taught to complete academic course, LMS analytical report and report on current level of teachers' ICT competence.

This suggested model allows realizing recommended approach to creating and applying EER in academic process for OES at HEI that promote staff digital competence.

From systematic point of view, EER projects can be regarded as artificial, direct managed system that promotes staff quality enforcement to project, create and apply EER, to manage process of introducing this system into schooling. Key elements of computer orientated environment at HEI are LMS projecting issues that really matter.

Introducing ICT at HEI can be directly connected with staff learning through involving learners to introducing a certain EER type [28].

In relation to the model there was created the project of integrating EER into the learning process at HEI including four main stages: 1) preparatory work (IT infrastructure analysis); 2) projects in computer orientated OES; 3) OES information content; 4) further LMS system employment by tutors at HEI.

To realize the project at the RAEU, the team was formed that includes project manager, course coordinator, analyst, system administrator, programming engineer, test manager, manager in audio and video projects, tutors.

The project is developed in PMBoK standards containing description of the project organization structure (outer and inner structure and project working team, working structure including WBS, CBS, CTR-dictionaries, matrices of responsibility). Project calendar and network planning is promoted. Its visual appearance is presented through Gant's diagram.

Main output of the project is LMS system integrated into learning process of the HEI (for example, Moodle / OPEN EDX) together with specially created modules and also EER made on its basis.

Projects in EER for OES at HEI include four principal stages: preparatory that implies IT infrastructure analysis for HEI, correction stages for computer orientated environment, its information content and LMS application (for example, Moodle/ OPEN EDX) by tutors.

Calculations were provided for economic profit of the project promotion and approximate price of its

operating by the team of various specialists during 352 working days. According to calculations, the project's price including wages for participants, amortizing expenses, social insurance fund payments and material expenses will make 327 500, 4 hrn. As LMS promotion will allow the university to improve competing positions and as a result attract more applicants, the term for the system to become profitable can be stated as that resulting from university's profit from additional fees compared with average fees obtained before. Optimal level makes 125 000 hrn a year, so the project can become profitable in 2 years and 8 months.

Transmission to education process based on active LMS employment and on staff quality enforcement based on ICT will allow HEI improve rating among other institutions and increase number of applicants at the expense of competing terms of schooling that is organized in electronic (distance) or hybrid format.

**Conclusion.** Task of promoting modern ICT into education process through university projects synchronous to programs of staff qualification enforcement in jobs is still important. Level of learning activity at the HEI depends on well-prepared workers ready to act professionally in hybrid and computer learning, so constantly acting system of qualification improvement is considered a means of their digital competence.

Digital competence should promote wide range of its elements: from media literacy to processing and critical evaluation of information data, safety and cooperation in the I-net to digital techniques and devices, ability of applying open resources and techniques for professional progress, for teaching students to use digital resources and services in studying and in private life, to solve various problems and tasks, to apply new technologies for evaluating their learning output and solving professional matters with digital technologies.

Complex attitude to solving ICT promotion problems can be exercised through creating open systems for staff qualification improvement.

ICT integration into learning process should be accompanied by proper preparation of staff and students to cooperate and interact in modernized information and education environment at HEI. Suggested model of creating EER for OES at HEI is regarded as modern tendency in digital infrastructures and can be related to prospective projects for digital transformations on local scale in education sphere in harmony with European and global education and scholar initiatives.

Staff qualification enforcement for OES, combination of different forms of teaching with broad application of ICT means create computer orientated environment for EER projects that may be substituted by LMS and LCMS.

Further research can be presented as creating and promoting automated management of business processes at HEI and training for digital transformation of education.

## References

1. Morze, N. V., Buinytska, O. P. (2017). Pidvyshchennia rivnia informatsiino-komunikatsiinoi kompetentnosti naukovo-pedahohichnykh pratsivnykiv – kluchova vymoha yakosti osvithnoho protsesu [Raising information and communication technologies competence of scientific and pedagogical employees – a key requirement of the quality of educational process]. *Informatsiini tekhnologii i zasoby navchannia – Information Technologies and Learning Tools*, vol. 59, no. 3, pp. 189-200. DOI: <https://doi.org/10.33407/itlt.v59i3.1667> [in Ukrainian].
2. Pro zatverdzhennia Natsionalnoi ekonomichnoi stratehii na period do 2030 roku: Postanova Kabinetu Ministriv Ukrainy vid 3 bereznia 2021 r. № 179 [On the approval of the National Economic Strategy for the period until 2030: Resolution of the Cabinet of Ministers of Ukraine of March 3, 2021 No. 179]. Retrieved from <https://www.kmu.gov.ua/npas/pro-zatverdzhennya-nacionalnoyi-eko-a179> [in Ukrainian].
3. Pro Natsionalnu stratehiiu rozvytku osvity v Ukraini na period do 2021 roku: Ukaz Prezydenta Ukrainy vid 25 chervnia 2013 roku № 344/2013 [On the National Education Development Strategy in Ukraine for the period until 2021: Decree of the President of Ukraine dated June 25, 2013 No. 344/2013]. Retrieved from <http://zakon3.rada.gov.ua/laws/show/344/2013> [in Ukrainian].
4. Pro skhvalennia Kontseptsii rozvytku tsyfrovoy ekonomiky ta suspilstva Ukrainy na 2018-2020 roky ta zatverdzhennia planu zakhodiv shhodo yii realizatsii: Rozporiadzhennia Kabinetu Ministriv Ukrainy vid 17 sichnia 2018 r. № 67-r [On the approval of the Concept of Development of the Digital Economy and Society of Ukraine for 2018-2020 and the approval of the plan of measures for its implementation: Decree of the Cabinet of Ministers of Ukraine dated January 17, 2018 No. 67]. Retrieved from <https://zakon.rada.gov.ua/laws/show/67-2018-%D1%80#Text> [in Ukrainian].
5. Morze, N. V., Boiko, M. A., Vember, V. P., Buinytska, O. P. (2020). ZVIT 4\_Profil vykladacha z napriamku tsyfrovoy kompetentnosti z vykorystanniam innovatsiinykh instrumentiv navchannia [REPORT 4\_Building the digital competence teacher profile by innovative teaching instruments]. *Open educational e-environment of Modern University, Special Edition "UA Pedagogical Higher Education: Profound Analysis and Study"*. (pp. 1-71). DOI: <https://doi.org/10.28925/2414-0325.2020spv4> [in Ukrainian].
6. Antonchenko, M. O. et al. (2021). Rozvytok informatsiino-tyfrovoy kompetentnosti pedahohichnykh pratsivnykiv v umovakh pislidyplomnoi osvity [Development of information and digital competence of teachers in the context of postgraduate education]. Sumy, Mriia [in Ukrainian].
7. Deiaki pytannia pidvyshchennia kvalifikatsii pedahohichnykh i naukovo-pedahohichnykh pratsivnykiv: Postanova Kabinetu Ministriv Ukrainy vid 21.08.2019 roku № 800. [Some issues of improving the qualifications of teaching and research-pedagogical workers: Resolution of the Cabinet of Ministers of Ukraine dated August 21, 2019 No. 800]. Retrieved from [https://osvita.ua/legislation/Ser\\_osv/65634/](https://osvita.ua/legislation/Ser_osv/65634/) [in Ukrainian].
8. Pro vnesennia zmin do Polozhennia pro elektronni osvithni resursy: Nakaz Ministkrstva osvity i nauky Ukrainy vid 29.05.2019 roku № 749 [On amendments to the Regulation on electronic educational resources: Order of the Ministry of Education and Science of Ukraine dated 05/29/2019 No. 749]. Retrieved from <https://ips.ligazakon.net/document/view/Re33637?an=85> [in Ukrainian].
9. Bykov, V. (2010). Vidkryte navchalne seredovyshe ta suchasni merezhni instrumenty system vidkrytoi osvity [Open learning environment and modern network tools of open education systems]. *Naukovyi chasopys Natsionalnoho pedahohichnoho universytetu imeni M.P. Drahomanova. Seriya 02: Kompiuterno-orientovani systemy navchannia – Scientific journal of M. P. Dragomanov National Pedagogical University. Series 2: Computer-based learning systems*, 9, pp. 9-15 [in Ukrainian].
10. Bykov, V. (2008). Modeli orhanizatsiinykh system vidkrytoi osvity [Models of the open education organizational systems]. Kyiv, Atika [in Ukrainian].
11. Bykov, V., Leshchenko, M. (2016). Tsyfrova humanistychna pedahohika vidkrytoi osvity [Digital humanistic pedagogy of open education]. *Teoriia i praktyka upravlinnia sotsialnymy systemamy: filozofia, psykholohiia, pedahohika, sotsiologiia – Theory and practice of social systems management: philosophy, psychology, pedagogy, sociology*, 4, pp. 115-130 [in Ukrainian].
12. Leshchenko, M. P., Yatsishin, A. V. (2014). Vidkryta osvita u katehorialnomu poli vitchyznanykh uchenykh [Category of "Open education" in the works of native and foreign scientists]. *Informatsiini tekhnologii i zasoby navchannia – Information Technologies and Learning Tools*, Vol. 39, No. 1, pp. 1-16. DOI: <https://doi.org/10.33407/itlt.v39i1.985> [in Ukrainian].
13. Buinytska, O. P., Hrytseliak, B. I. (2013). Student v informatsiino-osvithnomu seredovysheci suchasnoho universytetu [The student in the information and educational environment of the modern university]. *Informatsiini tekhnologii i zasoby navchannia – Information Technologies and Learning Tools*, Vol. 36, No. 4, pp. 66-83. DOI: <https://doi.org/10.33407/itlt.v36i4.865> [in Ukrainian].
14. Karplyuk, S. O. (2019). Osoblyvosti tsyfrovizatsii osvithnoho protsesu u vyshchii shkoli [Peculiarities of digitalization of the educational process in higher education]. *Informatsiino-tyfrovoyi osvithni prostir Ukrainy: transformatsiini protsesy i perspektyvy rozvytku [Information and digital educational space of Ukraine: transformation processes and prospects of development]*. Proceedings of the methodological seminar of the National Academy of Sciences of Ukraine. (pp. 188-197). Kyiv [in Ukrainian].
15. Sedov, V. (2015). Informatsiino-komunikatsiini tekhnologii, yak katalizator zmin kompetentnosti vykladacha [Information and communication technologies as a catalyst of changing of teacher's competence]. *Open educational e-environment of modern university*, 1, pp. 74-82. DOI: <https://doi.org/10.28925/2414-0325.2015.1.7482> [in Ukrainian].
16. Scott, C. (2015). The Futures of Learning 3: What kind of pedagogies for the 21st century? *Education, research and foresight: working papers*, No. 15. Retrieved from <https://unesdoc.unesco.org/ark:/48223/pf0000243126>.
17. Ferrari, A. (2011). Digital Competence in Practice: An Analysis of Frameworks. Luxembourg, Publications Office of the European Union. Retrieved from <https://ifap.ru/library/book522.pdf>. DOI: <https://doi.org/10.2791/82116>.
18. Morze, N., Vasylenko, S., Gladun, M. (2018). Shliakhy pidvyshchennia motyvatsii vykladachiv universytetiv do rozvytku yikh tsyfrovoy kompetentnosti [Ways to improve the motivation of university teachers to develop their digital competence]. *Open educational e-environment of modern university*, 5, pp. 160-177. DOI: <https://doi.org/10.28925/2414-0325.2018.5.160177> [in Ukrainian].
19. Myroshnychenko, O. A. (2020). Zmist i struktura tsyfrovoy kompetentnosti maibutnykh pedahohiv zakladiv vyshchoi osvity [Content and structure of digital competence of future teachers of higher education institutions]. *Pedahohika formuvannia tvorchoi osobystosti u vyshchii i zahalnoosvithnii shkolakh – Pedagogy of creative personality formation in higher and general education schools*. 2020. Vol. 3, No. 70. P. 119-183. DOI: <https://doi.org/10.32840/1992-5786.2020.70-3.22> [in Ukrainian].
20. Shcherbyna, O. A. (2021). Otsiniuvannia yakosti elektronnykh navchalnykh kursiv dlia zakladiv vyshchoi osvity [Organisation of teachers' advanced vocational training while implementing blended learning at the university]. *Informatsiini*

*tehnologii i zasoby navchannia – Information Technologies and Learning Tools*, Vol. 83, No. 3, pp. 353-370. DOI: <https://doi.org/10.33407/itlt.v83i3.3350> [in Ukrainian].

21. Shcherbyna, O. A. (2018). Proektuvannia elektronnykh osvithnikh resursiv dlia system pidvyshchennia kvalifikatsii vidkrytoho universytetu [Designing of electronic educational resources for open university proficiency improvement systems]. Kyiv, CPC "Comprint" [in Ukrainian].

22. Bykov, V., Lapinsky, V. (2012). Metodolohichni ta metodychni osnovy stvorennia ta vykorystovuvannia elektronnykh zasobiv navchalnoho pryznachennia [Methodological and methodical bases for the creation and use of electronic teaching aids]. *Kompiuter u shkoli ta simi – Computer at school and family*, 2, pp. 3-6 [in Ukrainian].

23. Morze, N. V., Buinytska, O. P., Varchenko-Trotsenko, L. O. (2016). Stvorennia suchasnoho elektronnoho kursu v systemi MOODLE [Creating a modern e-learning course MOODLE]. Kamianets-Podilskyi, Buynytsky O. A. [in Ukrainian].

24. Skhidnoievropeyskyi universytet imeni Raufa Ablyazova [Rauf Ablyazov East European University]. *E-learning*. Retrieved from [https://suem.edu.ua/e\\_learning](https://suem.edu.ua/e_learning) [in Ukrainian].

25. Shcherbyna, O. A. Vidkryta sistema pidhotovky vykladachiv yak zasib vprovadzhennia informatsiinykh tekhnologii v universyteti [An open system of teacher training as a means introduction of information technologies at the university]. Retrieved from <http://2018.moodleuoi.in.ua/course/view.php?id=31> [in Ukrainian].

26. Titenko, S. V., Gagarin, O. O. (2012). Model navchalnoho Web-kontentu Tree-Net yak osnova dlia intehtatsii keruvannia znanniamy i bezperervnym navchanniam [Learning Web-content Tree-Net model as a basis for integration of knowledge management and on-going learning]. *Systemni doslidzhennia ta informatsiini tekhnologii – Systems research & Information technologies*, No. 1, pp. 74-95 [in Ukrainian].

27. LMS and LCMS Demystified. (2007). *Elearning!*, vol. 3, no. 2, pp. 25-28. Retrieved from [www.brandon-hall.com/free\\_resources/lms\\_and\\_lcms.shtml](http://www.brandon-hall.com/free_resources/lms_and_lcms.shtml).

28. PMBOK Guide. 6th Edition. Retrieved from <https://www.deepfriedbrainproject.com/2018/03/pmbok-version-6-available-for-download.html>.

29. Hutsaliuk, O. M., Holovina, O. I., Kozlovitseva, V. A. (2019). Formuvannia innovatsiinoi infrastruktury natsionalnoi ekonomiky v umovakh hlobalizatsii ta intehtatsii [Formation of innovative infrastructure of the national economy in conditions of globalization and integration]. *Infrastruktura rynku – Market infrastructure*, 33, pp. 381-487. DOI: <https://doi.org/10.32843/infrastruct33-56> [in Ukrainian].

30. Hutsaliuk, O. M., Havrylova, N. V. (2020). Vplyv marketynhovykh, finansovykh ta tsyfrovyykh tekhnologii na rozvytok infokomunikatsiinoi sfery, yak skladovoi innovatsiinoi infrastruktury [Influence of Marketing, Financial and Digital Technologies in the Development of Infocommunication Sphere as a Component of Innovation Infrastructure]. *Visnyk ekonomichnoi nauky Ukrainy*, 2 (39), pp. 166-171. DOI: [https://doi.org/10.37405/1729-7206.2020.2\(39\).166-171](https://doi.org/10.37405/1729-7206.2020.2(39).166-171) [in Ukrainian].

31. Kramskyi, S. O., Hutsaliuk, O. M., Ablyazova, N. R., Maltsev, M. M. (2023). Vykorystannia proiektnoho menedzhmentu yak innovatsiino-enaivronmentalnoho pidkhodu v systemi pidhotovky fakhivtsiv z ekonomiky ta upravlinnia naukovo-tekhnichnoiu sferoiu [The Use of Project Management as an Innovative and Environmental Approach in the System of Training Specialists in Economics and Management of the Scientific and Technical Sphere]. *Ekonomichnyi visnyk Donbasu – Economic Herald of the Donbas*, 3 (73), pp. 88-96. DOI: [https://doi.org/10.129\\_58/1817-3772-2023-3\(73\)-88-96](https://doi.org/10.129_58/1817-3772-2023-3(73)-88-96) [in Ukrainian].

### **Манькута Я. М. Посилення економічної взаємодії інформаційно-комунікаційних технологій в інноваційному проєктуванні діяльності позашкільних освітніх закладів з використанням електронних навчальних ресурсів**

Стаття присвячена питанням формування цифрової компетентності педагогічних працівників освітніх закладів (ОЗ) у межах власної програми підвищення кваліфікації за місцем роботи. Зазначається, що питання проєктування і розробки електронних освітніх ресурсів (ЕОР) з використанням сучасних інформаційно-комунікаційних технологій (ІКТ) актуалізуються в контексті цифровізації освіти, активізації використання технологій змішаного і дистанційного навчання в карантинних умовах роботи ОЗ.

У статті розглянуто основні підходи до визначення змісту цифрової компетентності викладачів; електронного навчання; основні види ЕОР, які формують відкрите освітнє середовище ОЗ. Визначено інструменти ІКТ і методику для побудови моделі проєктування, створення і використання ЕОР. Підвищення кваліфікації викладачів у межах університету розглядається як корпоративне навчання, тому для його реалізації пропонується застосування концепції управління знаннями шляхом створення репозитарію цифрового навчального контенту. Серед сучасних методів проєктування ЕОР найефективнішими вважаються CASE-технології, які базуються на використанні інструментальних засобів структурного аналізу та моделювання. Для функціонального моделювання процесів створення комп'ютерно-орієнтованого середовища проєктування ЕОР обрано модель IDEFO.

Опис базової моделі «Проєктування ЕОР для відкритого освітнього середовища» деталізується до необхідного рівня за допомогою діаграм декомпозиції. Специфіку моделі проєктування ЕОР для відкритого освітнього середовища відображають функції дослідження поточного стану освітнього середовища, розробки програмних модулів системи управління знаннями, створення ЕОР, а також власне освітнього процесу та підвищення кваліфікації. Оскільки проєкт з упровадження ІКТ в ОЗ синхронізується з процесом підвищення кваліфікації викладачів через їх залучення до розробки і впровадження певного виду ЕОР, запропонована модель дозволяє подальше використання ЕОР в освітньому процесі.

У Східноєвропейському університеті імені Рауфа Аблязова (м. Черкаси) за стандартом РМВоК було розроблено проєкт, основним продуктом реалізації якого є інтегрована в освітній процес університету LMS-система разом із спеціально розробленими модулями, а також створені на її основі ЕОР.

**Ключові слова:** економічна взаємодія, інформаційно-комунікаційні технології, інноваційно-проєктна діяльність, електронні навчальні ресурси, відкрите освітнє середовище, економічний розвиток, конкурентоспроможність, проєктування електронних освітніх ресурсів, позашкільні освітні заклади.

### **Mankuta Ya. Strengthening the Economic Interaction of Information and Communication Technologies in The Innovative Design of Activities of Extracurricular Educational Institutions Using Electronic Educational Resources**

The article is devoted to the issues of forming the digital competence of pedagogical workers of educational institutions within the framework of their own professional development program at the place of work. It is noted that the issues of designing and



developing electronic educational resources (EER) using modern information and communication technologies (ICT) are actualized in the context of the digitalization of education, the activation of the use of mixed and distance learning technologies in the quarantine conditions of work of educational institutions.

The article considers the main approaches to determining the content of the digital competence of teachers; e-learning; the main types of EOR, which form the open educational environment of OZ. ICT tools and methods for building a model of design, creation and use of EOR are defined. Improving the qualifications of teachers within the university is considered as corporate training, therefore, for its implementation, it is proposed to apply the concept of knowledge management by creating a repository of digital educational content. Among the modern methods of EOR design, the CASE technologies, which are based on the use of structural analysis and modeling tools, are considered the most effective.

The IDEF0 model was chosen for the functional modeling of the processes of creating a computer-oriented EOR design environment. The description of the basic model "Designing EOR for an open educational environment" is detailed to the required level with the help of decomposition diagrams. The specificity of the EOR design model for an open educational environment is reflected by the functions of researching the current state of the educational environment, developing software modules of the knowledge management system, creating EOR, as well as the actual educational process and professional development. Since the project on the introduction of ICT in health care is synchronized with the process of improving the qualifications of teachers through their involvement in the development and implementation of a certain type of EOR, the proposed model allows the further use of EOR in the educational process.

At Rauf Ablyazov East European University (Cherkasy), a project was developed according to the PMBoK standard, the main product of which is an LMS system integrated into the educational process of the university along with specially developed modules, as well as EOR created on its basis.

*Keywords:* economic interaction, information and communication technologies, innovative project activity, electronic educational resources, open educational environment, economic development, competitiveness, designing of electronic educational resources, extracurricular educational institutions.

Creative Commons Attribution 4.0  
International (CC BY 4.0)



Received by the editors 02.11.2023