

# EXPERIMENTAL METHODS AND PROCESSING OF DATA

<https://doi.org/10.46813/2022-139-114>

## HF RADIATION PULSE SOURCE LOCATING IN DIN-2K ACCELERATOR

*O.S. Druj, V.V. Yegorenkov, S.V. Marchenko, V.B. Yuferov*

*National Science Center "Kharkov Institute of Physics and Technology", Kharkiv, Ukraine*

*E-mail: yvv4827@gmail.com*

Experiments aimed at locating the source generating an HF pulse during the opening of the plasma switch and leading to explosive electron emission at the cathode were performed on DIN-2K pulse accelerator. It is demonstrated that certain lamps glow during the explosive electron emission pulse. This may point to the possible HF pulse generation during the opening of a plasma switch or radial interruption of current. In order to locate the radiation source the FR-2 dielectric insert was introduced into the vacuum diode and Ne lamps were placed over the anode mesh. The thickness of this insert was chosen to be larger than the electron penetration depth. The lack of Ne indicator lamps glow when the anode was shielded by an FR-2 insert was observed as opposed to the case of operation with the vacuum diode as a load. The virtual cathode caused by the explosive emission from the cathode is shown to be the source of HF radiation.

PACS: 52.75. - d, 94.20.wc

### INTRODUCTION

The DIN-2K setup is a pulse electron accelerator with inductive energy storage and a plasma opening switch [1].

DIN-2K main chamber schematics is shown in Fig. 1. Here 1 is the Rogowski coil for measuring the Current Pulse Generator (CPG) current, 2 is the high voltage insulator, 3 is the plasma gun unit, 4 is the Rogowski coil for measuring load current, 5 is the cathode of inductive energy storage coaxial line, 6 is the setup body serving as an anode for the inductive energy storage, 7 is the PMMA output flange.

The Rogowski coil 1 is designed for measuring pulses of current with microsecond duration and has a sensitivity of 1740 A/V. The Rogowski coil 2 is designed for measuring pulses of current with about 100 ns duration and has a sensitivity of about 40 A/V. In our experiments measurements with this coil were conducted through a 1:20 voltage divider.

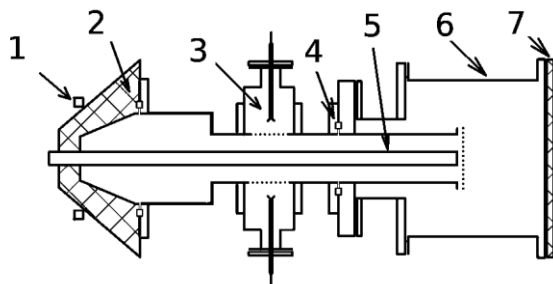

Fig. 1. Experimental setup

During the accelerator operation cycle current pulses in its power circuits are generating broad band HF electromagnetic radiation. The goal of the following experiments was finding out the regions of the setup generating the maximum power of HF radiation.

For this purpose the following experiments registering the glow of neon indicator lamps were conducted:

1. The vacuum diode with circular cathode and flat mesh anode serves as a load for inductive energy stor-

age. Neon indicator lamps are placed on the setup output flange.

2. PMMA plate is put between the cathode and the mesh anode of the vacuum diode. Indicator lamps are placed on the setup output flange.

3. An FR-2 plate is put between the cathode and mesh anode of the vacuum diode. FR-2 was chosen as a dielectric for the barrier for its optical opacity to lower the plasma bridge glow intensity in the shot. Indicator lamps were placed on the anode mesh.

4. An FR-2 plate is put after the anode mesh near the vacuum diode and then another anode mesh is put after the dielectric barrier plate. Indicator lamps are fastened to the second anode mesh. On the output flange additional indicator lamps were placed.

Hypothetically the virtual cathode was formed when the inductive storage discharged through the vacuum diode. Once formed the virtual cathode leads to the HF oscillation of current and HF radiation generation. The dielectric inserts in the vacuum diode are impeding the virtual cathode formation. Hence the HF radiation should not occur. Moreover, if the HF radiation source happens to be from the side of the coaxial line of the accelerator there would be an anode mesh between the radiation source and the measuring equipment. The presence of such a shield would lead to the HF radiation attenuation or even its full reflection.

### 1. THE ANODE MESH SHIELDING PROPERTIES

In [2] the relations between the electromagnetic field attenuation  $B$  by a metallic mesh made from wires of  $r$  radius and placed on the distance  $a$  from one another for short wave radiation with the wavelength of  $\lambda$  are shown (Fig. 2).

In the experiments described the anode mesh was made from the stainless steel wire with 0.15 mm radius. The distance between wires was 1 mm. The  $a/r$  parameter was roughly 6.67, which tells us that in the range of wavelengths from 5 to 20 mm the attenuation was no less than 20 dB.

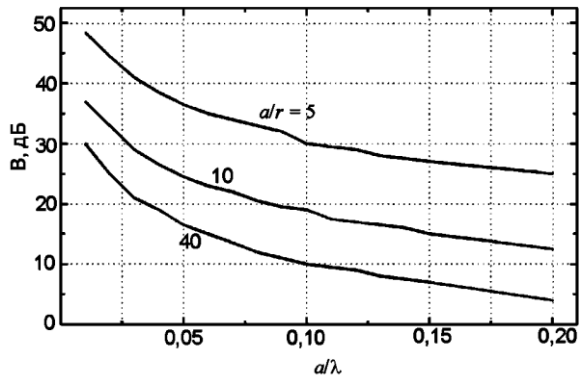

Fig. 2. HF radiation attenuation by metallic mesh

## 2. EXPERIMENTAL RESULTS

### 2.1. VACUUM DIODE

The neon lamp glow was registered by Canon 550D camera in a video mode. For this experiment the output flange was obscured by a black cloth curtain. The indicator lamps, the scintillator and several self-reading pocket dosimeters were placed over the curtain. Neon lamps glow under the influence of HF electric field [3] while the scintillator glows from the X-ray excited luminescence [4]. The PCG charging voltage –  $U_c = 25$  kV, plasma gun power source is charged to  $U_p = 8$  kV, the cathode-anode distance in a vacuum diode –  $d = 6$  mm.

The brightest photo is shown in Fig. 3. For the clear picture the brightness of the shot was increased by a factor of five during post-processing.

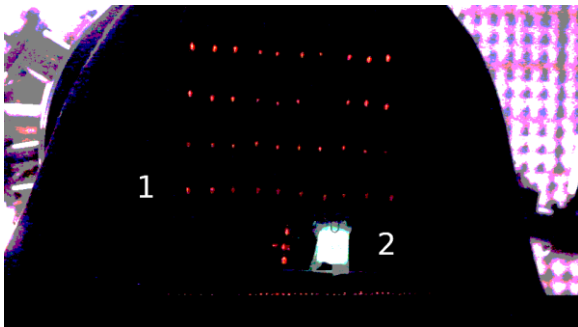

Fig. 3. Neon lamp glow:

1 – glowing neon lamps; 2 – CsI(Tl) scintillator glow

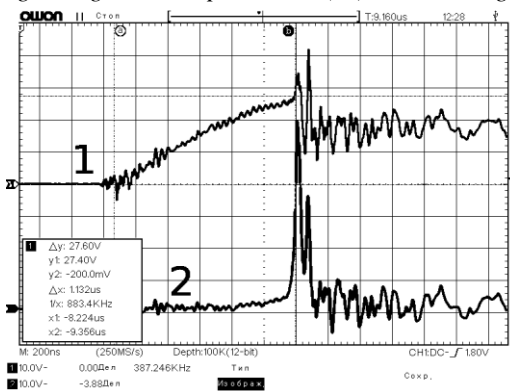

Fig. 4. Oscillograms

The Rogowski coils signals in this experiment are shown in Fig. 4. 1 is the PCG current (see coil 1 from Fig. 1), 2 is the current in the diode load (see coil 4 from Fig. 1). Self-reading pocket dosimeter DK-02 placed in the same plane as the indicator lamps showed 50 mR.

Thus we see that when the inductive storage is discharging through the vacuum diode the X-ray radiation is registered at the same time as the glow of neon indicator lamps. This shows that the source of the HF radiation is located between the anode mesh and the output flange of the setup as the mesh anode serves as a shield for the electromagnetic radiation emitted from the coaxial line of the accelerator.

### 2.2. VACUUM DIODE WITH A PMMA BARRIER

For this experiment the main chamber of the accelerator was rearranged according to Fig. 5. Between the cathode 1 and a mesh anode 3 a PMMA barrier 2 was placed. The barrier thickness – 3 mm is much larger than the electron penetration depth under the maximum expected accelerating voltage. Such a barrier is impeding the formation of virtual cathode in the space between an anode mesh 3 and the output flange 4.

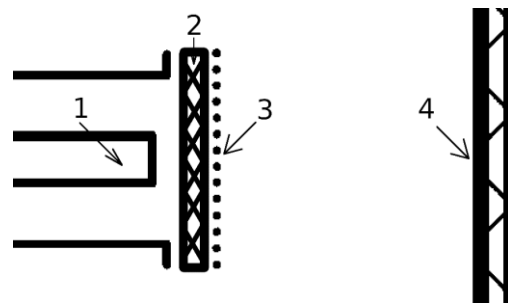

Fig. 5. Dielectric barrier in a vacuum diode

Same as the experiment above, the neon lamp glow was captured by Canon 550D camera in a video recording mode. In this experiment the glow was not present. The X-ray radiation was not registered neither by the scintillator glow nor by the DK-02.

Rogowski coils signals in this experiment are shown in Fig. 6. The measuring circuit is the same as in the first experiment.

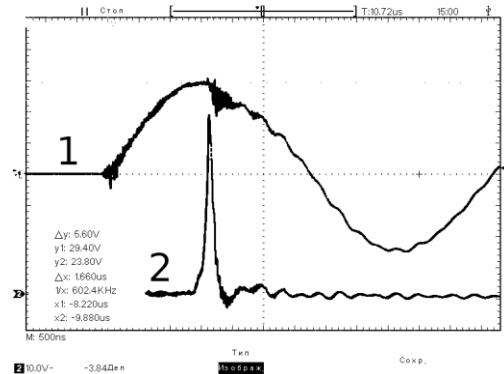

Fig. 6. Oscillograms of currents

From this we can assume that when the inductive storage operates while loaded with a vacuum diode with a PMMA plate between the electrodes there is no X-ray radiation nor neon lamp glow. Electrons can't reach the anode and there is no X-ray nor HF radiation.

### 2.3. VACUUM DIODE WITH FR-2 BARRIER

In this case the setup was similar to the one shown on Fig. 5 with the only difference that there were neon lamps fastened to the anode mesh. The snapshot was taken through the output flange. Fig. 7 shows the brightest frame.

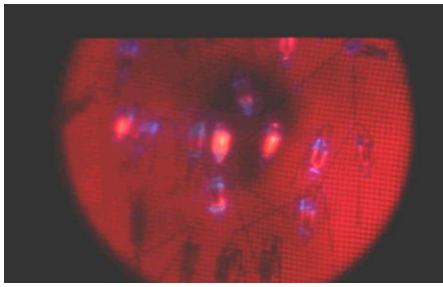

Fig. 7. Neon lamp glow on the anode mesh

It is easy to see the light from the plasma bridge shining through the FR-2. The neon lamps glow brightest near the cathode (a dark spot in the middle of the red circle). If we shift the color balance to the blues and increase the contrast (Fig. 8) we will see clearly the neon lamp's glass luminescence under the X-ray excitation [5].

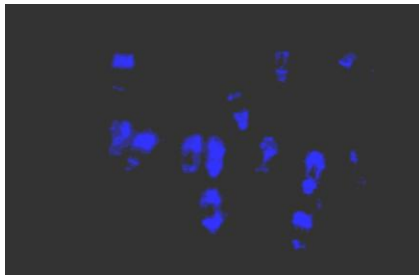

Fig. 8. Glass luminescence

If we process the frame shown in Fig. 7 such that the color of the glow discharge in neon is the most prominent we can observe that the glow distribution of neon discharge does not coincide with that of the X-ray excited luminescence in glass. The brightest glowing lamps happen to be near the edge of the cathode, yet they don't show the brightest blue glow (Fig. 9).

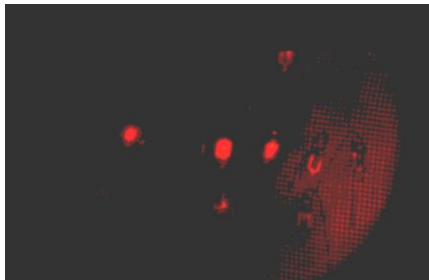

Fig. 9. Neon gas discharge glow

From this experiment one can state that when there is a dielectric barrier in the vacuum diode of DIN-2K in the immediate vicinity of the diode generation of X-ray and HF radiation is still possible. It probably occurs during the current interruption process in the plasma opening switch and the explosive electron emission from the cathode. The intensity distributions of these types of radiation do not coincide.

#### 2.4. VACUUM DIODE WITH AN FR-2 BARRIER BETWEEN TWO ANODE MESHES

The vacuum diode assembly is shown in Fig. 10. Cathode 1 and the nearest to it anode mesh 3 form a vacuum diode. An FR-2 barrier 2 is placed between the anode meshes 3.

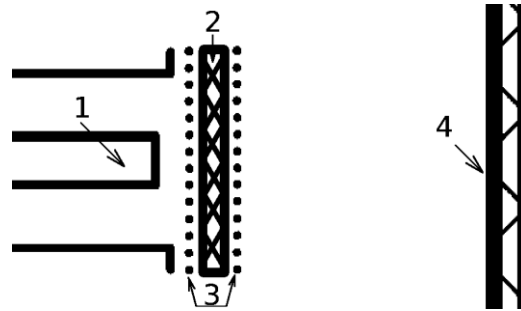

Fig. 10. Experiment 4 setup

Neon lamps and the scintillator glow were captured by Canon 550D camera in manual exposition mode (Fig. 11).

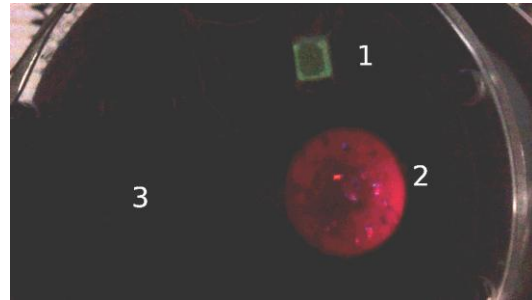

Fig. 11. Neon lamps and scintillator glow

In Fig. 11 we see 1 is the scintillator glow, 2 is the glow of neon lamps and the light from plasma bridge punching through the FR-2. 3 marks the area where the neon lamps fastened to a plate of FR-2 were placed on the output flange of the accelerator. In Fig. 3 these lamps are glowing and marked as 1.

Let us consider the neon lamp glow in the area near the vacuum diode with a dielectric barrier.

Fig. 12 shows the zoomed in area 2 in Fig. 11. It was processed in such a way as to amplify the blue light of the neon lamps glass caused by X-ray radiation and the reddish glow of gas discharge in them caused by HF electric field.

Comparing the results of the last two experiments we can surmise that the presence of anode mesh in front of the dielectric barrier in a vacuum diode does not improve HF radiation generation but neither does it make such generation impossible.

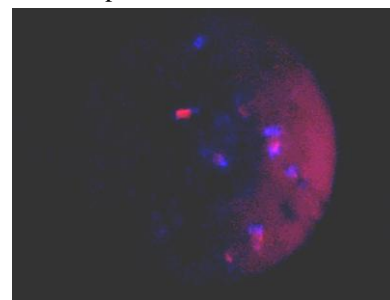

Fig. 12. Glow of glass and neon of the lamps

## CONCLUSIONS

The paper show that the virtual cathode forming in behind the anode mesh during the electron beam pulse is the source of radiation.

In the experiments with a dielectric barrier in a vacuum diode this may explain the absence of the glow of

lamps placed on the output flange of the accelerator chamber with the simultaneous presence of such glow in lamps placed on the anode mesh itself. The formation of a virtual cathode in the space between the anode mesh and the output flange of the accelerator could lead to the generation of HF electric field strong enough to cause a discharge in neon lamps (see Fig. 3). At the same time placing a dielectric barrier impeding the formation of virtual cathode in front of the anode mesh made registering the HF radiation near the output flange impossible due to the shielding effect of the anode mesh. Yet generation of the HF radiation seems to be still possible in such a case (see Fig. 11).

#### REFERENCES

1. O.S. Druj, V.V. Yegorenkov, I.M. Onyshchenko, V.B. Yuferov. Plasma dynamics in accelerator with plasma opening switch // *Problems of Atomic Science and Technology*. 2019, № 6, p. 77-80.
2. O.S. Ostrovskij, E.N. Odarenko, A.A. Shmat'ko. Zashchitnye ekrany i poglotiteli elektromagnitnykh voln // *Fizicheskaya Inzheneriya Poverxnosti*. 2003, v. 1, № 2, p. 161-173 (in Russian).
3. Y. Yamamoto, H. Kidooka, Y. Honda, S. Yasuda. Measurement of intense microwave field patterns using a neon glow indicator lamp // *International Journal of Infrared and Millimeter Waves*. 1995, v. 16, № 3, p. 579-589.
4. I. Valais, D. Nikolopoulos, N. Kalivas, et al. A systematic study of the performance of the CsI:Tl single-crystal scintillator under X-ray excitation // *Nuclear Instruments and Methods in Physics Research*. 2007, A 571, p. 343-345.
5. T. Yoshida, Sh. Muto, T. Tanabe. Measurement of soft x-ray excited optical luminescence of a silica glass // *13-th International Conference on X-Ray Absorption Fine Structure (XAFS13)*. 9-14 July, 2006, Stanford, California.

Article received 01.02.2022

### ВИЗНАЧЕННЯ ДЖЕРЕЛА ІМПУЛЬСУ ВЧ-ВИПРОМІНЮВАННЯ НА ПРИСКОРЮВАЧІ ДІН-2К

*О.С. Друй, В.В. Єгоренков, С.В. Марченко, В.Б. Юферов*

На імпульсному прискорювачі ДІН-2К були проведені експерименти з метою визначення джерела генерації ВЧ-імпульсу при розмиканні плазмового ключа та генерації вибухової емісії електронів з катоду. Показано, що при екрануванні пучка електронів від аноду діелектричною вставкою з органічного скла, при чому довжина пробігу електронів у діелектрику менша за її товщину, на виході з вікна прискорювача не реєструвалися спалахи індикаторних неонових ламп, що постійно виникали при відсутності вставки. Для визначення джерела випромінювання була встановлена гетинаксова вставка, та індикаторні неонові лампи були розміщені на анодній сітці. Експерименти показали частковий спалах ламп при імпульсі вибухової емісії, що свідчить про можливе проходження ВЧ-імпульсу при розмиканні плазмової перетинки, або радіальному розмиканні струму. Показано, що джерелом випромінювання є віртуальний катод, що утворений вибуховою емісією катоду.

### ОПРЕДЕЛЕНИЕ ИСТОЧНИКА ИМПУЛЬСА ВЧ-ИЗЛУЧЕНИЯ НА УСКОРИТЕЛЕ ДИН-2К

*О.С. Друй, В.В. Егоренков, С.В. Марченко, В.Б. Юферов*

На импульсном ускорителе ДИН-2К были проведены эксперименты с целью определения источника генерации ВЧ-импульса при размыкании плазменного ключа и генерации взрывной эмиссии электронов с катода. Показано, что при экранировании пучка электронов от анода диэлектрической оргстеклянной вставкой, причем длина пробега электронов в диэлектрике меньше ее толщины, на выходе из окна ускорителя не наблюдались вспышки индикаторных неоновых ламп, которые постоянно возникали при отсутствии вставки. Для определения источника излучения была поставлена гетинаксовая вставка, и индикаторные неоновые лампы были размещены на анодной сетке. Эксперименты показали частичное зажигание ламп при импульсе взрывной эмиссии, что свидетельствует о возможном прохождении ВЧ-импульса при размыкании плазменной перемычки, либо радиальном размыкании тока. Показано, что источником излучения является виртуальный катод, образованный взрывной эмиссией катода.