

AXIAL COIL ACCELERATOR OF PLASMA RING IN THE ATMOSPHERIC PRESSURE AIR

K.V. Korytchenko, V.F. Bolyukh, O.L. Rezinkin, S.G. Burjakovskij, O.P. Mesenko
National Technical University "Kharkov Polytechnic Institute", Kharkiv, Ukraine
E-mail: korytchenko_kv@ukr.net, tel. +38057-707-66-34

An axial coil accelerator for acceleration of plasma formation having intrinsic magnetic field in the atmosphere is designed. A problem of a round plasma formation in the atmospheric pressure air is solved by electrical wire explosion where an initial form of an exploding wire corresponded to a ring. A vortex current into the created plasma ring is inducted by the coil accelerator to generate intrinsic magnetic field of the plasma formation. This process is synchronized with reduction in the magnetic coupling between the plasma formation and the accelerator coil during the acceleration.

PACS: 52.59.Dk

INTRODUCTION

An energy source is required to convert gas into gas plasma under atmospheric conditions. The plasma lifetime corresponds to duration of the energy input plus the plasma relaxation time mainly. The relaxation time under atmospheric conditions typically ranges from nanoseconds to microseconds depending on size and thermodynamic state of the plasma [1]. Thus the extended plasma lifetime can be achieved by increasing the duration of the energy input.

A lifetime extension of gas plasma in the atmospheric pressure air without its confining by an external energy source has a scientific interest [2-6]. An internal energy source of a plasma formation can allow growing in the plasma lifetime. Energy of the plasma formation stored in a magnetic field is considered as the internal energy source. A vortex current in a plasma formation having a round shape was induced to generate an intrinsic magnetic field of the plasma ring. An axial coil accelerator is applied for a generation of a vortex current in a plasma ring.

Design of pulsed plasma inductive accelerators was described in works [7]. But given accelerators cannot be used under atmospheric conditions due to problem of formation of highly ionized gas in a round region.

The aim of this work is to design a discharge plasma device for pulsed inductive acceleration of the plasma-ring formation in the atmospheric air. An additional task is an investigation of conditions when the intrinsic magnetic field of the plasma-ring formation rises during the ring acceleration.

CREATION OF PLASMA RING IN THE ATMOSPHERIC AIR

We divided a process of a plasma ring formation having the intrinsic magnetic field in the atmospheric pressure air into next three stages:

1. Formation of a round plasma region filled with thermally highly ionized gas in the surrounding atmospheric pressure air;
2. Induction of a current into the created plasma ring by an axial coil accelerator;
3. Accumulation of energy in the intrinsic magnetic field of the plasma-ring during the ring acceleration.

A problem of a round plasma formation in the atmospheric pressure air was solved in the following way. We use electrical wire explosion to generate plasma in the air. An initial form of an exploding wire corresponded to a ring. Thus we obtained an electrically-conducting ring region filled with thermally highly ionized gas.

We designed an experimental scheme to test of the plasma ring formation in the atmospheric pressure air (Fig. 1). Type of wiring near electrical connectors 2 corresponded to a twisted pair and then it transformed into a wire ring 1 to exclude the influence of boundary effects of the connectors on continuity of plasma ring formation (see Fig. 1). Copper wires were used. A wire diameter was 0.1 mm. A diameter of the wire ring was 70 mm. ИК-1-100-0.25 pulse capacitor was used as a pulsed energy source. Its capacitance equaled 0.25 μF . Breakdown voltage of a passive crowbar switch was (10 ± 1) kV.

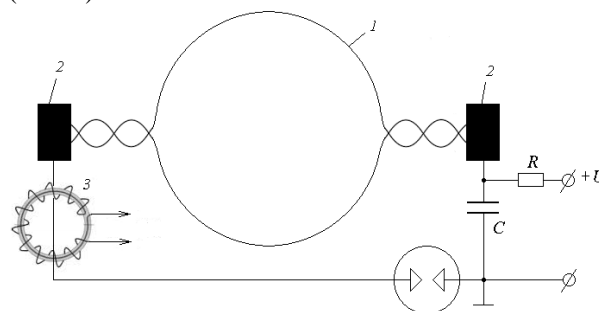

Fig. 1. Experimental scheme for testing of the plasma ring formation in the atmospheric pressure air: 1 – exploding wires; 2 – connectors; 3 – current transformer

We registered a front view of the exploding wire (Fig. 2). We observed a dark region 2 in the center of the explosion. A shape of the outer high-temperature region 1 was similar to a ring.

The plasma formation time is determined by a time delay Δt of the wire explosion and it is usually several microseconds. It is necessary to measure the time delay to synchronize the wire explosion with induction of the current into thermally ionized plasma.

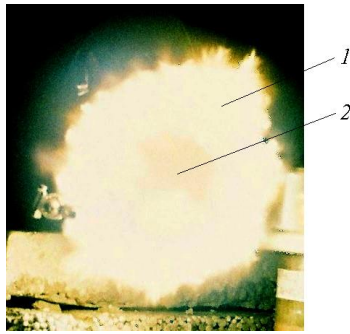

Fig. 2. A front view of the exploding wire:
1 – exploding region; 2 – geometric centre

We measured the discharge current to find out the time delay. The measured result is presented on Fig. 3. Point on the current curve where there is rapid changing into a gradient of the discharge current corresponds to the wire explosion. We found out that the time delay was $\Delta t = (300 \pm 50)$ ns. We observed that the total discharge time of the wire explosion was about $1 \mu\text{s}$. Thus we assumed that a time difference in explosions of two wires did not exceed the total discharge time.

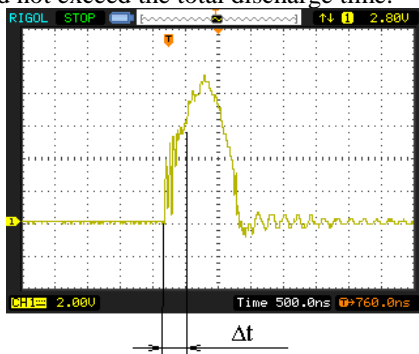

Fig. 3. Current curve of the wire explosion.
The scale is 2000 A/div

It has to note that synchronization of explosions of two wires forming the ring is determined by wire resistance changing during the explosion. When one wire starts exploding earlier than another wire it leads to growth of a resistance of the first wire. As a result there is a rise in a discharge current of the second wire. It accelerates an explosion of the second wire.

We designed a special coil accelerator (Fig. 4). The wire ring 1 was axially located over an inductor 2. The inductor was connected with a capacitor C_2 via a switch K_2 . The switch was turned on simultaneously as the ring conducting region was formed to accelerate the plasma ring. During the acceleration a dynamic energy exchange happens between the capacitor, the inductor, and the ring due to magnetic and electric coupling. The plasma acceleration causes a reduction in a mutual inductance of the inductor and the ring. We try to achieve the fast reduction in the mutual inductance when a ring current is maximal to store energy of a magnetic field in the plasma ring.

A total capacitance of the capacitor C_1 equalled $2.7 \mu\text{F}$. The capacitor was charged to a voltage of 30 kV. Copper wire of a rectangular cross section of $(1.5 \times 4) \text{ mm}^2$ was used to make the coil. Number of turns of the single-layer coil was 6.

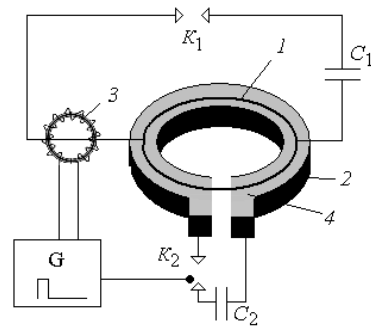

Fig. 4. Experimental scheme of an axial coil accelerator: 1 – exploding wire; 2 – coil; 3 – current transformer; 4 – dielectric layer; G – generator; $K_{1,2}$ – switches

The coil wire was isolated by fluoroplastic film. An inner coil diameter was 40 mm. An outer coil diameter was 80 mm. The coil inductance was (1850 ± 50) nH. The active coil resistance was 0.026Ω . We measured a discharge current in the inductor circuit without connecting any load to the circuit to determine a total circuit inductance. The total inductance was $2.25 \mu\text{H}$.

The ring exploding wire acceleration was investigated using video cameras. Images of a light-emitting region motion in the atmospheric pressure air are given on Fig. 5. A wire expansion was supersonic during the explosion. Then we observed a motion of a light-emitting region from the inductor. Speed of the motion was subsonic and it equaled to 50 m/s during the electromagnetic acceleration. A lifetime of the region was above 10 ms.

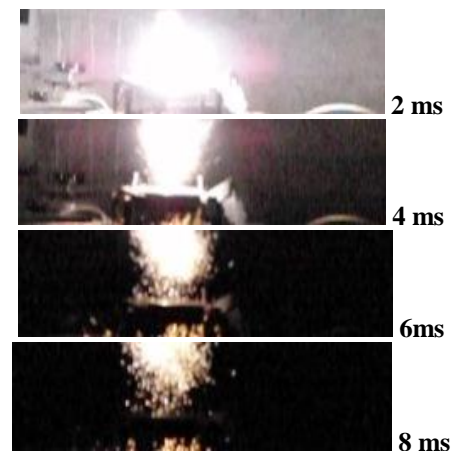

Fig. 5. Images of a light-emitting region motion in the atmospheric pressure air

A detachment of plasma formation from the inductor was observed (Fig. 6).

We suggested that there was accumulation of energy in the intrinsic magnetic field of the plasma-ring during the ring acceleration because the ring lifetime differed by one order of magnitude with duration of the inductive acceleration.

A simplified numerical model of the accelerator was developed to find out conditions when the energy of magnetic field stores in the ring. A circuit model of a pulsed inductive accelerator is presented (Fig. 7).



Fig. 6. A view of the plasma formation above the coil

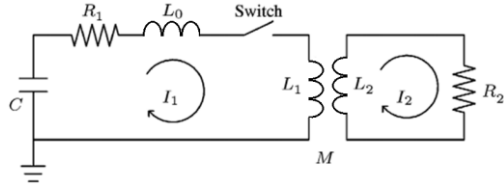

Fig. 7. Circuit model of a pulsed inductive accelerator

We used differential equations (1) - (5) of transient process in electrical circuits including magnetic coupling of the inductor and the ring to investigate the accelerator. A system of equations was written as [2]

$$R_1 i_1 + (L_0 + L_1) \frac{di_1}{dt} + C^{-1} \int i_1 dt + M \frac{di_2}{dt} + V i_2 \frac{dM}{dz} = 0, \quad (1)$$

$$R_2 i_2 + L_2 \frac{di_2}{dt} + M \frac{di_1}{dt} + V i_1 \frac{dM}{dz} = 0, \quad (2)$$

$$f = i_1 \cdot i_2 \frac{dM}{dz}, \quad (3)$$

$$V = m^{-1} \int f dt, \quad (4)$$

where M is a mutual inductance; f is Lorentz force; R is a resistance; L_0 is a circuit inductance; L_1 is a coil inductance; L_2 is a ring inductance; C is a capacitance; i is a current; V is a velocity of the ring; t is time; z is axial coordinate; m is weight of the ring.

Values of circuit and coil inductances and resistor corresponded to measured data. A plurality of non-stationary process such as gas-dynamic expansion, ionization, vaporization, dissociation, radiation happens during the ring explosion and inductive acceleration. Thus it is a problem to predict changing into the ring inductance, resistance and weight. We varied with these values to investigate a possible influence of the ring evolution on the acceleration process. The ring explosion causes the initial ring velocity. We varied with the initial ring velocity too. A mutual inductance depended on a current distance between the coil and the ring.

Energy accumulated in the intrinsic magnetic field of the plasma-ring was calculated by equation

$$Q_m = L_2 \frac{i_2^2}{2}. \quad (5)$$

Initial conditions assume that the capacitor is charged and an initial capacitor voltage is $U_0 = 30$ kV. There is no initial current in the circuit.

A calculated ring inductance was $L_2 = 95$ nH by the next ring dimension. An outer ring diameter was 80 mm. An inner diameter was 60 mm. A ring height was 10 mm. Influence of the ring resistance on discharge current in a ring loop was investigated when the ring weight was 1 mg. The simulation data is presented on Fig. 8.

We observed from the simulated data that there was a current oscillation during the first stage of the acceleration.

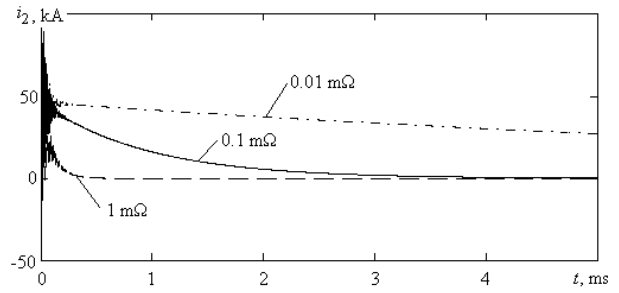

Fig. 8. Time dependence of the ring current by the different ring resistance

The duration of this stage was about 200...300 μ s. The energy of magnetic field accumulated in the ring loop at the end of the first stage. Then an exponential decrease in the discharge current happened during the second stage. The duration of the 2nd stage was depended on the ring resistance. Thus we can assume that a ring plasma lifetime is related to the ring resistance.

Simulated data of Lorentz force accelerated the ring is presented on Fig. 9. The ring resistance was 0.1 m Ω .

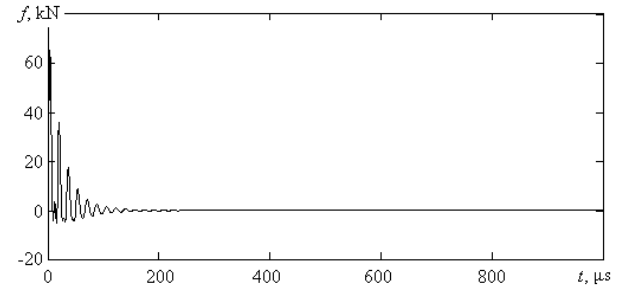

Fig. 9. Time dependence of the Lorentz force

We observed from the simulated data that electromagnetic acceleration of the ring happened during the 1st stage. The Lorentz force reduced at the end of the 1st stage due to dumping of an oscillating discharge current and decrease in the mutual inductance.

We cannot predict using the designed numerical scheme an influence of air resistance to the ring motion on the energy accumulation. So the inertia force was varied to investigate the influence.

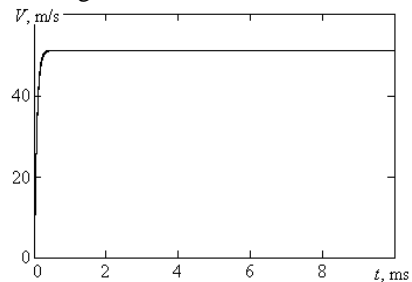

Fig. 10. Time dependence of the ring velocity

Simulated data of the ring velocity when the ring weight was 100 mg and the ring resistance was 0.1 m Ω is presented on Fig. 10. A maximal value of the velocity corresponded to experimental value. The simulation data for this case is presented on Fig. 11.

The energy of magnetic field accumulated in the ring loop too. A simulated total discharge time is practically the same as an experimental time of intensive irradiation of plasma formation.

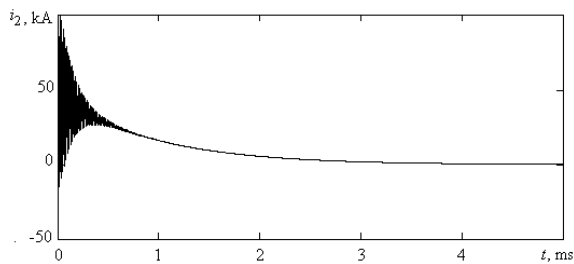

Fig. 11. Time dependence of the ring current when the ring weight was 100 mg

Energy accumulated in the intrinsic magnetic field of the plasma-ring is presented on Fig. 12.

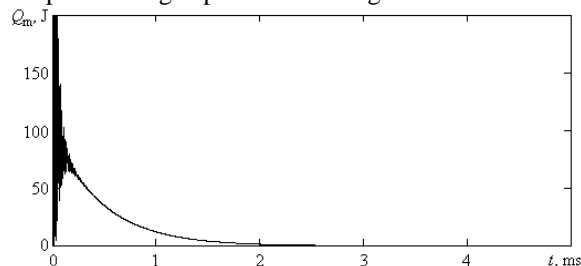

Fig. 12. Time dependence of the energy of magnetic field accumulated in the ring

The simulated data demonstrates that the energy of magnetic field exceeded 60 J at the end of the first stage of the acceleration. Such a value is low to achieve a change in plasma features as predicted at work [7]. Thus we plan to increase the energy using more powerful accelerator than it was applied in this work.

CONCLUSIONS

A discharge plasma device for pulsed inductive acceleration of the plasma-ring formation in the atmospheric air has been designed. A problem of a round plasma formation in the atmospheric pressure air was

solved by an explosion of electrical wire having a round shape. An axial coil accelerator was used to induce a current into the created plasma ring.

Conditions when the intrinsic magnetic field of the plasma-ring formation rises during the ring acceleration have been investigated. It has been found out that a ring plasma lifetime rises when the ring resistance falls.

REFERENCES

1. Yu.P. Raiser. *Gas discharge physics*. M.: "Nauka", 1987, 592 p.
2. O.V. Sakun, V.F. Bolyukh, O.P. Mesenko, K.V. Korytchenko. Investigation of conditions of stable plasma ring induction by coil accelerator // *Electrical Engineering and Electromechanics*. 2015, № 1, p. 63-67 (in Russian).
3. F.D. Witherspoon, A. Case, S.J. Messer. A contoured gap coaxial plasma gun with injected plasma armature // *Review of Scientific Instruments*. 2009, v. 80, p. 083506-15.
4. J. Guo. Induction Plasma Synthesis of Nanomaterials // *Plasma Science and Technology – Progress in Physical States and Chemical Reactions*. Chapter 1, 2016, p. 3-30.
5. S.F. Schaer. Coaxial plasma gun in the high density regime and injection into a helical field // *Helvetica Physica Acta*, 1994, v. 67 (2), p. 217-218.
6. C. Seward. Ball lightning events explained as self-stable spinning high-density plasma toroids or atmospheric spheromaks // *IEEE journal*. 2014, v. 2, p. 153-159.
7. S.G. Fedosin. Physical theory of lighting ball // *Applied physics*. 2001, № 1, p. 69-87.

Article received 30.09.2018

АКСИАЛЬНЫЙ ИНДУКТИВНЫЙ УСКОРИТЕЛЬ ПЛАЗМЕННОГО КОЛЬЦА В ВОЗДУХЕ АТМОСФЕРНОГО ДАВЛЕНИЯ

К.В. Корытченко, В.Ф. Болюх, О.Л. Резинкин, С.Г. Буряковский, А.П. Месенко

Разработана техника создания и ускорения плазменного формирования с собственным магнитным полем в атмосферной среде. В основу разработанной техники положено формирование газоплазменной среды в виде кольца в атмосферной среде путем электрического взрыва проводника в виде кольца, последующего индуцирования вихревого тока в газоплазменной среде при помощи индукционного ускорителя и обеспечение условий для накопления энергии магнитного поля в плазменном формировании путем его электродинамического ускорения, что обеспечивает ослабление магнитной связи между плазменным формированием и индуктором ускорителя.

АКСІАЛЬНИЙ ІНДУКЦІЙНИЙ ПРИСКОРЮВАЧ ПЛАЗМОВОГО КІЛЬЦЯ В ПОВІТРІ ЗА АТМОСФЕРНОГО ТИСКУ

К.В. Корытченко, В.Ф. Болюх, О.Л. Резинкин, С.Г. Буряковский, О.П. Месенко

Розроблена техніка створення та прискорення плазмового формування з власним магнітним полем в атмосферному середовищі. В основу розробленої техніки покладено формування газоплазмового середовища у вигляді кільця в атмосферному середовищі шляхом електричного вибуху провідника у вигляді кільця, подальшого індукування вихрового струму в газоплазмовому середовищі за допомогою індукційного прискорювача та забезпечення умов для накопичення енергії магнітного поля в плазмовому формуванні шляхом його електродинамічного прискорення, що забезпечує послаблення магнітного зв'язку між плазмовим формуванням та індуктором прискорювача.