

..

-

" " "

, 3, , , 49008; e-mail: edgladky@gmail.com

()/ () ().

, , , -

, , , -

() ,

, , , -

(,) , -

, , , ; -

, , , -

« -4 »:

; - ; ; -

()/ ().

() ().

, , , -

()

, , , -

) , (

, , , ;

, , , -

« -4 »:

; - ; ; -

Launch complex (LC) facilities and systems run the highest risk in the case of a launch vehicle / integrated

© . . . , 2020

. - 2020. - 1.

launch vehicle accident at lift-off or at the initial flight phase. Various measures are taken to improve their safety by increasing their resistance to a failed launch vehicle' damaging factors, first and foremost, an explosion shock wave. A way to do so is to berm a facility on one or several sides or to use special protective barriers. This reduces the pressure in the explosion shock wave front incident onto the protected side of the facility.

This paper presents mathematical models of risk (damage probability) assessment for a bermed launch complex facility. The facility area is described by a convex polygon. Using the example of the side of a facility facing the launch vehicle launch point, two berm types depending on the berm length are considered, and geometrical models are proposed to represent the damage area of the facility. In the first case where the berm length is far longer than the facility side length, for the risk to be assessed the damage area is split into two parts: a polygon, which accounts for the initial safety of the facility, and a rectangle, which corresponds to the bermed side and accounts for the berm-caused reduction of the shock effect. In the second case where the berm length is equal to the facility side length, the damage area is split into several figures: a polygon (the facility area) and trapezoids constructed on the facility sides. The trapezoid that corresponds to the bermed side facing the launch point accounts for the berm-caused reduction of the shock effect. Based on the proposed representations of the damage areas of a bermed facility, relationships to calculate the risk are proposed.

As an example, damage probability assessment is made for two facilities of the Cyclone-4M launch complex: a liquid oxygen filling system and a thermostating system.

Keywords: launch vehicle, flight safety, in-flight launch vehicle accident, failed launch vehicle fall area, risk, berm.

()

» [6].

[7, 8]).

() , ().

().

1 2

Atlas 5 Falcon (),



. 1 – Atlas-5 ().



. 2 – Falcon (SpaceX,)

,
 ,
 .
 () ,
 [4] ,
 ,
 2 () .
 [3] .
 -
 ()
 ,
 ()
 .
 ()
 () .

$$R = Q \sum_{j=1}^{N_{\Delta t}} P_{\Delta t_j} \frac{1}{\Delta t_j} \int_{t_{j-1}}^{t_j} \Delta R(t) dt, \quad (1)$$

Q -
 $P_{\Delta t_j}$ -
 $[t_{j-1}, t_j]$; $\Delta R(t)$ -
 t .

()

$A_1A_2A_3A_4A_5$

. 3).

[1] (

t

(R).

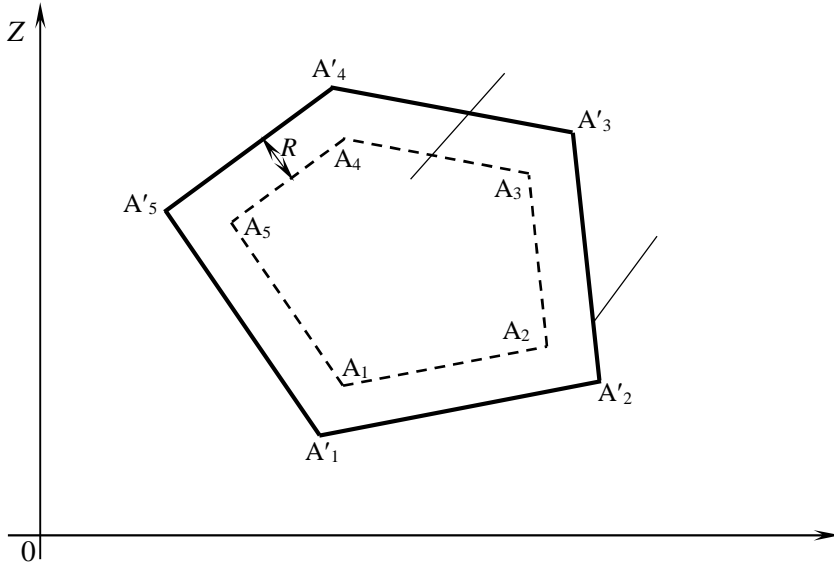

. 3 -

$$A'_i(x_i, z_i) \quad i = \overline{1, N_0} \quad (N - \dots)$$

A_i

R

$$R_0 = \sum_{N_0-2} R_{\Delta i}, \quad (2)$$

$R_{\Delta i}$

i

$N - 2$.

$R_{\Delta i}$

[1].

$$R_{\Delta} = \iint_{\Delta} f_{X,Z}(x, z; m_X(t), m_Z(t), \dagger_X(t), \dagger_Z(t)) dx dz,$$

$f_{X,Z}(x, z; \bullet) -$

$; m_X(t), m_Z(t), \dagger_X(t), \dagger_Z(t) -$

)

t.

4.

(),

. 5).

(R),

R 1 (

),
2R 1.

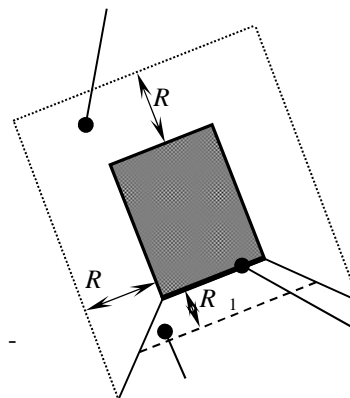
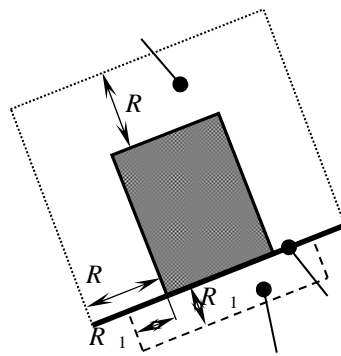

. 4 -

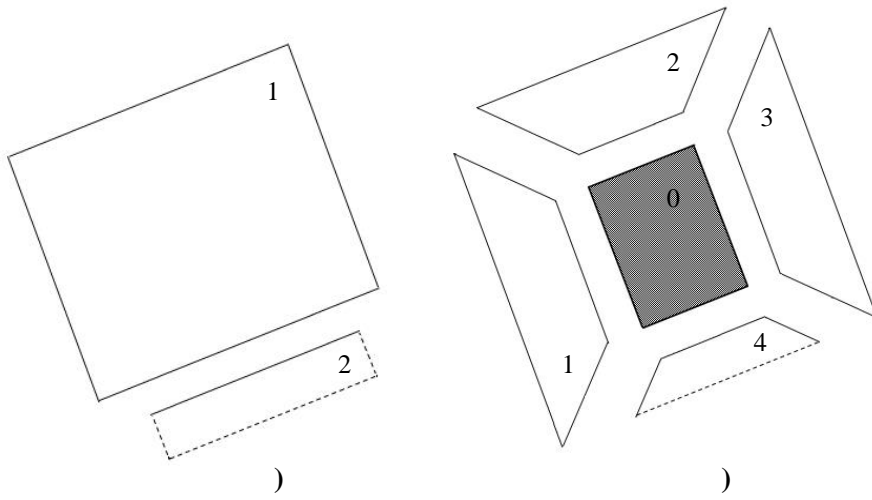

.5-

(5)

:

$$R = Q \sum_{j=1}^{N_{\Delta t}} P_{\Delta t_j} \frac{1}{\Delta t_j} \left[\int_{t_{j-1}}^{t_j} \Delta R_{-1}(t) dt + \int_{t_{j-1}}^{t_j} \Delta R_{-2}(t) dt \right], \quad (3)$$

$\Delta R_{-1}(t)$ -
 () -
 $t; \Delta R_{-2}(t)$ -
 ().

(5)): , (0; $N + 1$ -

(1 - 4). R_{-1} ,

$$R = Q \sum_{j=1}^{N_{\Delta t}} P_{\Delta t_j} \frac{1}{\Delta t_j} \left[\int_{t_{j-1}}^{t_j} \Delta R_{-0}(t) dt + \sum_{i=1}^N \int_{t_{j-1}}^{t_j} \Delta R_{-i}(t) dt \right], \quad (4)$$

$\Delta R_{-0}(t)$ -
 $t; \Delta R_{-i}(t)$ -
 (5).

$\Delta R_{-0}(t), \Delta R_{-i}(t)$ (4)

$\Delta R_{-1}(t), \Delta R_{-2}(t)$ (3),

(2).

R_1

(R).

« -4 » (. 6):
()

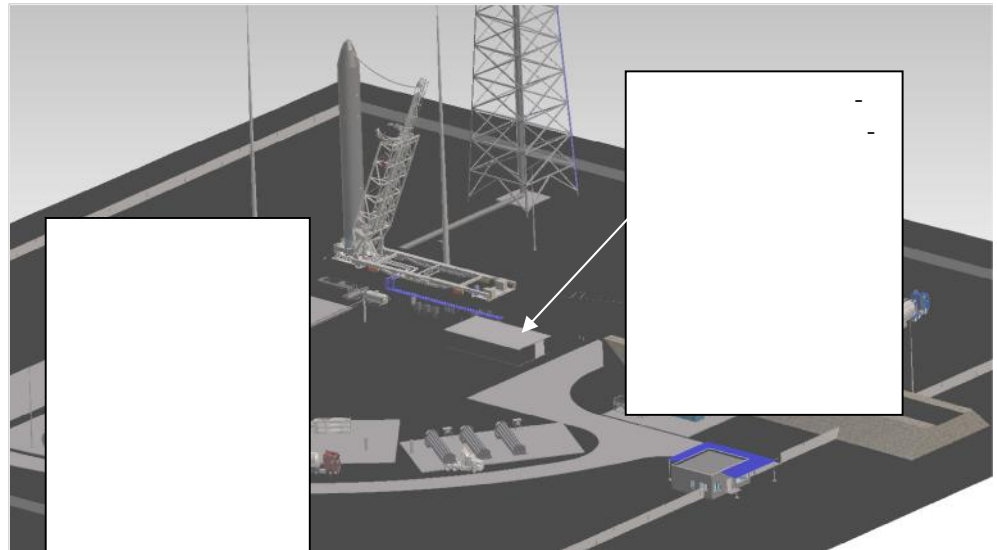

. 6 -

« -4 »

(0,05 - 0,15) / ² (0,1 / ²).

0,2 / ².
« -4 »

(70 - 80)

« -4 »

[5]

7.

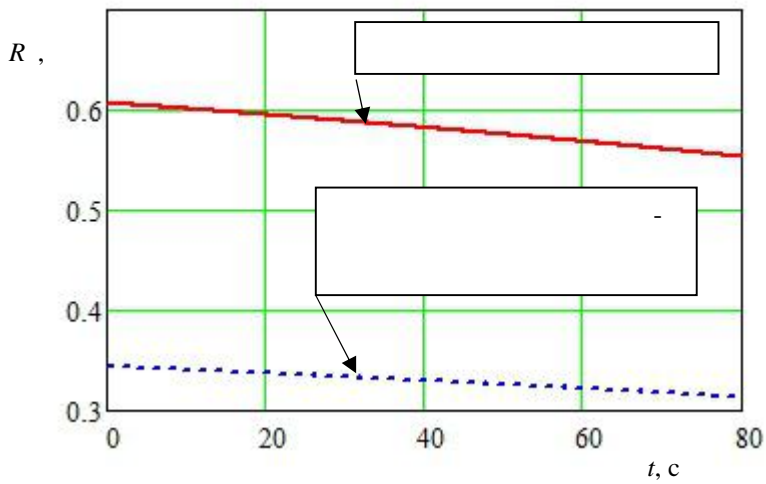

.7 -

« -4 »

0,013.

« -4 »

[1].

« -4 »

(t),

1.

1 -

« -4 »

(

)

t ,	m_x ,	$(\pm 3\sigma)$	
		$\pm \Delta L_x$,	$\pm \Delta L_z$,
0	0	0	0
10	0,01	0,05	0,05
20	0,03	0,07	0,07
30	0,17	0,46	0,41
40	0,66	0,86	0,76
50	1,83	1,38	1,21
60	4,42	2,60	2,24
70	8,88	3,46	3,16
80	16,34	4,45	4,29

« -4 »

,
+90°; -90°

30

15

(3) (4)

[2].

. 8. « -4 »
 ~ 70 , -765^2 .

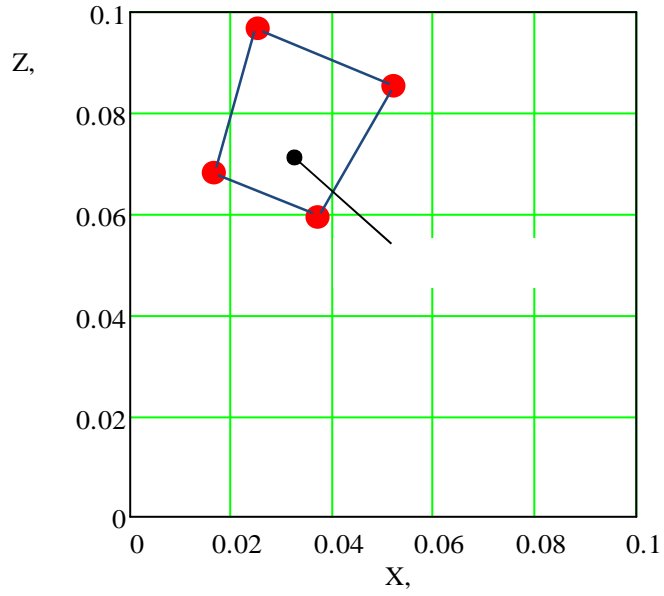

. 8 - « -4 »

$1,53 \cdot 10^{-4}$.

« -4 ».

≈ 2

$1,36 \cdot 10^{-4}$.

(4)

$1,04 \cdot 10^{-4}$.

(« -4 » (36 6))

120^2 .

« -4 »

(3), $5,17 \cdot 10^{-5}$.

$7,82 \cdot 10^{-5}$.

4,0·10⁻⁵.

« -4 »

1.
2. : : ,2015. .3. .50-56.
3. : « « »,2011. .2. .266-280.
4. 13-01-92
5. : ,2010. 468 .
6. X. : « »,2006. 408 .
7. ISO 14620-1:2008. .1. (ISO 14620-1:2002, IDT). [01.10.2008]. ,2009. 38 .
8. 14 CFR. Chapter III. Commercial space transportation, Federal aviation administration, Department of transportation, Subchapter C – Licensing, part 417 – Launch Safety, 2001 []. URL: <http://law.cornell.edu/cfr/text/14/part-417>.

28.12.2019,
17.02.2020