

УДК 004.81

*Y.I. Kyslenko*

National Technical University of Ukraine

«Igor Sikorsky Kyiv Polytechnic Institute», Ukraine

37, Peremohy av., Kyiv, 03056

## PERSONIFIED COGNITIVE FEEDBACK AS A POWERFUL INSTRUMENT FOR PROGRESSIVE ACCELERATION OF SOCIAL EVOLUTION

*Ю.І. Кисленко*

Національний технічний університет України

«Київський політехнічний інститут імені Ігоря Сікорського», Україна

пр. Перемоги, 37, м. Київ, 03056

## ПЕРСОНІФІКОВАНИЙ КОГНІТИВНИЙ ЗВОРОТНИЙ ЗВ'ЯЗОК ЯК ПОТУЖНИЙ ВАЖЕЛЬ ПРОГРЕСИВНОГО ПРИСКОРЕННЯ РОЗВИТКУ СУСПІЛЬСТВА

The concept of personified cognitive feedback (PCF) is introduced, which takes place in human neural network between the accumulated knowledge potential and new information. This feedback may always be considered as positive, taking into account experience accumulation. This connection itself provides the process of “understanding” while comparing each component and the message as a whole with the recipient’s current cognitive potential. When projecting the peculiarities of PCF realization onto the society in general, a powerful conclusion can be made that it is the multitude of separate individual PCFs with their significant creative potential and unlimited communication capabilities that enables the continuous growth of the global cognitive potential, which, in its turn, determines the “progressive acceleration of social evolution”.

**Keywords:** figurative level situation, basic semantic-syntactic structure, personified cognitive feedback

Вводиться поняття персоніфікованого когнітивного зворотного зв'язку (ПКЗЗ) в нашій нейромережі між накопиченим потенціалом знань та новою інформацією. Такий зв'язок завжди вважатимемо позитивним з урахуванням процедури накопичення досвіду. Власне, такий зв'язок і забезпечує процес «розуміння», зіставляючи як кожен складову, так і загалом все повідомлення з поточним когнітивним потенціалом реципієнта. Коли ж спроектувати особливості актуалізації ПКЗЗ на суспільство загалом, то доходимо потужного висновку: що саме множина окремих індивідуальних ПКЗЗ з їх потужним креативним потенціалом та необмеженими можливостями комунікації забезпечують постійне зростання глобального когнітивного потенціалу, що, в свою чергу, зумовлює «прогресивне прискорення розвитку суспільства».

**Ключові слова:** ситуація образного рівня, базова семантико-синтаксична структура, персоніфікований когнітивний зворотний зв'язок

### Introduction

From the standpoint of the structural and functional level of the organization of the individual language system, as a combination of the linguistic processor responsible for the synthesis and analysis of linguistic information, and the knowledge base, where all information is gathered both figurative and symbolic levels, the author analyzes the processes of interaction of these components on the way of updating various schemes of both speech activity and general human behavior. The concept of personalized cognitive feedback (PCF) in our neural network is introduced between the accumulated potential of knowledge and new information. The author believes that such a connection is always positive - taking into account the procedure of accumulation of experience. From the perspective of introspective analysis of the work of our network are considered as separate stages of the processing of arbitrary linguistic message, as well as the peculiarities of

verbalization of information of figurative nature. Actually, such a connection provides the process of "understanding", comparing both each component, and all messages, with the current cognitive potential of the recipient. When to design features of actualization of PCF to society as a whole, we arrive at the strong conclusion that the very set of individuals PCFs with their powerful creative potential and unlimited communication capabilities ensure the constant growth of global cognitive potential (GCP). Thus, we have an interesting sequence of cognitive potential formation. Personified cognitive feedback of an individual (PCF), during its life cycle, forms an individual cognitive potential (ICP), the totality of which forms the unique global cognitive potential (GCP) of a community that is constantly being adjusted and augmented, which in fact determines progressive acceleration development of society.

### **1. The concept of feedback, evolution of its perception and usage**

Perceiving the ideology of feedback has been one of the humans' powerful instruments for understanding the outside world and themselves. Feedback as the response to external signals, which forms as a result of comparing the current status with the previously accumulated experience, permeates human life and determines the existence of all things, the living matter in the first place. However, the first manifestations of this interrelation had been realized and used in engineering, then its principles were transferred to studying human body functions, later were used for analyzing communication process, and finally - for analyzing the information processes in human brain.

#### **1.1 Evolution of the concept of feedback**

**Feedback in engineering.** The concept of feedback has first been implemented in engineering for stabilizing the operation of certain instruments (e.g. Watt's governor in 1868). In general, feedback operates on the principle of considering the divergence between the desired operation mode of a piece of technical equipment and the actual one, and is successfully used in modern systems of automatic control. In this case the principle of deviation control is implemented. This feedback must be negative, as it constantly reduces the divergence between the assigned and the actual value of a certain attribute, ensuring steady operation of the equipment.

**Feedback in physiology.** Due to rapid technological advance, since mid-XX century science has turned to analyzing the functions of living creatures, and thoroughly studying the human body itself. Numerous principles of operation and interrelations known in engineering systems have been discovered to be relevant for analyzing and explaining the peculiarities of certain systems functioning in living bodies, and for understanding the human body as a whole. This ideology had been most elaborately studied and articulated by the prominent physiologist P.K. Anokhin, even before cybernetics was established as a generalized approach to analyzing control procedures in biological, social and engineering systems.

Human body has already been regarded as a combination of interrelated complex systems, each of them being able to regulate itself, thus maintaining internal stability of the whole body (defined as *homeostasis*). This process required each system to have a close-loop regulating system, implementing the feedback function. While negative feedback usually stabilizes and enhances system operation, positive feedback, on the contrary, increases the gain ratio, which allows to control significant energy currents, however compromising the stability of the system. *Interaction of these interrelated systems is supervised by the nervous system.* The astonishingly complex system organization of a human body was, in particular, demonstrated by the exhibition "Learn your body" (Kyiv, 2012).

**Cognitive feedback.** So, the idea of referring to the methods of system analysis for engineering, and later for studying the adaptive systems of living bodies, was gradually adopted by psychologists for studying human *cognitive* processes. The possibility to use the principle of feedback for analyzing communicative processes was first realized and introduced for scientific use by J. Chaplin in 1975 [1] with the purpose of analyzing communication processes between a speaker and a recipient. As opposed to using feedback in engineering and physiology, here the research is focused on communicative processes themselves. In particular, researchers or experts try to indirectly analyze the recipient's evaluation of the received information by external formal signs (body language, gestures, facial expressions, movements, approval, acceptance or rejection, concern etc). This method of evaluating the recipient's knowledge has been defined as *cognitive feedback* (CF). For the time being it is the only possibility to indirectly judge the recipient's evaluation of the semantic part of the speaker's message. Here the chain of data transmission and receipt from a speaker to a recipient can be clearly traced, but the quality of the received information can only be evaluated indirectly in terms of fuzzy logic ("like", "dislike", "good" or "not so good" etc). This is a virtual generalized connection "speaker-recipient", which is not directly connected to evaluation of the knowledge received by the recipient.

**Personified cognitive feedback.** Cognitive feedback referred to informational aspects of communication between a speaker and a recipient. The next evolutionary stage for the concept of cognitive feedback is rather radical – it concerns the *special aspects of information perception by the recipient (their neural network) as the new information is being compared to the current potential of accumulated knowledge, providing for the process of "understanding" the message*. However, since no objective data regarding identification of such processes in human neural network is available at the moment, the only way is to refer to my own *introspective* view on this phenomenon, based on my experience as described in the papers "Language Architecture" [2], «From Thought to Knowledge» [3], «Back to Basics of Speech Activity» [4].

It is worth noting that in this case we expand the concept of "cognitive feedback" to include perceiving and processing information on both symbolic and figurative levels, which are most intricately interwoven in the knowledge base and may not be studied and analyzed separately. Since arbitrary information received by different sensory systems is *represented in the same format on the neural level* after it had been processed by the relevant brain cortex (visual, auditory, gustatory etc), our memory can identically operate any incoming information in the neural network. It is worth noting that the verbal level only requires verbalization of arbitrary sensory information to a certain extent; the language itself as a symbolic data form may be realized on the visual (written or printed language) and acoustic (speech, song) levels, or may be represented indirectly via the sense of touch (as in the case of Braille alphabet).

*So, let the personified cognitive feedback be understood, generally speaking, as the process of comparing the information incoming to our memory through any channel with all the information accumulated and stored in the knowledge base at the given moment.*

Therefore, *the subject matter of the research is human speech activity, with special focus on the correlation between new information perceived by the human and the already accumulated knowledge*. This approach to human speech activity, which is a complicated intellectual function, is defined as *personified cognitive feedback (PCF)*, and is based on this author's introspective experience. It is actually solely individual (*personified*) feedback,

which is located in human neural network and is realized in the process of comparing new incoming data with all the knowledge potential accumulated earlier.

Let us emphasize that data processing via PCF is not specific for symbolic (language) data processing and may be used for processing arbitrary figurative information. New information may be received by two channels: either directly, by scanning the environment with the sensory system, or indirectly via verbal (communication) level, which excites the previously accumulated knowledge received on both figurative and symbolic levels. Here communication and cognitive processes actually interact, aiming at either transmitting the accumulated knowledge to a recipient, or vice versa, at receiving the knowledge unknown to the speaker from the recipient. Accordingly, the result of this interaction can be realized either on the symbolic level, or on the level of certain actions, depending on the person's intentions.

A good example of introspective analysis of the verbalization process for figurative information (which was received quite a long time ago, but has not been articulated yet), including visual and gustatory levels as well as the levels of muscular actions and odor perception, has been demonstrated by this author in the paper "From Thought to Knowledge" [3]. That case clearly demonstrated the unity of knowledge on the figurative and symbolic levels in human memory and the possibility of flexible transition from one step to the other.

Personified cognitive feedback constantly accompanies all human speech (and intellectual in general) activities, which are realized (according to L. Shcherba [5]) by the individual speech system (ISS) as a combination of a person's linguistic competence (the linguistic processor or LP) and the accumulated knowledge potential (the knowledge base or KB), where new incoming information is constantly being compared to the already accumulated knowledge. This symbolic level relation refers to perception of a verbal message by the recipient and is defined as "*understanding the message*".

The "understanding" process is successive, where individual components as well as the speaker's message as a whole are constantly being compared to the recipient's whole cognitive potential accumulated at the given moment. This case refers to the process of information perception by the recipient (or, more accurately, by their neural network), *independently of the recipient's external response to the received message*. Generally speaking, the recipient's response to the message is formed by the decision making system and depends on numerous individual factors, not only on the incoming message itself.

### **1.2 Special aspects of PCF realization**

As opposed to the previous examples of feedback, where two physical quantities (in engineering or in living bodies) were compared or evaluated by the speaker indirectly (by the recipient's external response to the incoming message – CFB), *the personified cognitive feedback (PCF) refers to analyzing the process of perception of new information by the recipient with regard to their accumulated cognitive potential*. Let us basically (or figuratively) define this feedback as positive, because in any case it results in accumulating or correcting the human's cognitive potential (KB); whether this information is considered positive or negative by the person, it is still an asset.

Clearly, the communication process is implemented (for human beings) mostly on the verbal level, while the cognitive level also engages all levels of the sensory system (visual, acoustic, sense of touch, smell, taste). The verbal level is defined as a universal method for reproducing and organizing knowledge on any level, while the assets of the sensory level (e.g. music, art) may not always be clearly realized and transmitted onto the

verbal level. When communicative intention (the desire to share one's assets with someone else) appears, we are always able to transmit (more or less adequately) figurative information onto the verbal level. That is why further research on the cognitive feedback is generally based on the results of analysis of perceiving and processing verbal information by human neural network.

At the moment informational treasures of a person's memory are impossible to reach, with the only exception of symbolic knowledge level, and only depending on the person's consent (and ability). However, mighty layers of symbolic level knowledge have been compressed in texts by the best of mankind, in particular, the priceless treasures of world and national literature.

Nevertheless, an almost insurmountable obstacle here is *the impossibility to automatically process* all literary legacy by a certain writer, author or person in general with modern electronic devices. This issue results from *two yet unsolved problems of the modern information national language technologies – lack of a semantic WEB and inability (for the time being) to form an efficient world model as an essential component of “understanding” a message*. Both of these problems result from inadequate knowledge of the neural organization of human memory in general and of the structure-functional level of organization of language as a symbolic form of data presentation in particular. However, the key problems of these topics, which have been clarified by this author in speech axiomatics in the paper “Back to basics of speech activity”, imply certain optimism regarding possible solutions for the above mentioned problems, and therefore understanding and modelling the special aspects of personified cognitive feedback operation in human neural substance.

So, when studying the communicative aspect of interaction between new information and the accumulated KB potential, the structure-functional level of a verbal message organization should be taken into account. This procedure is implemented by the linguistic processor, and it would be to the point to recall B.Y. Horodetskyi's idea that the main function of language is organization and presentation of knowledge [6]. So, generally speaking, the speaker *has to transmit figurative information onto the verbal level (by certain language canons) first, and only then is able to perform the communicative function*. In fact, these two processes are interconnected and are realized almost simultaneously and automatically.

The recipient's functions, on the other hand, are performed in reverse order: *when perceiving each message element, the recipient automatically (by the same language canons) addresses their KB, scans all associative environment (on both verbal and figurative levels) of the element, forecasts the possible scenario for further message and perceives the new element of the speaker's message, comparing it to the anticipated scenario*. Personified cognitive feedback is actually implemented in this cyclic process, allowing the recipient to perceive, evaluate and accumulate new information, and generally defining the process of “*understanding*” a message.

So, perceiving a message always requires the *recipient's forecasting potential*, which is based on their own competence, represented by their knowledge base cognitive potential, to be active and employed; this peculiar aspect provides perceiving and “understanding” the message by a recipient. If the message is not perceived (or understood) in whole or in part, the recipient contacts the speaker with the relevant additional questions or asks for clarification. This situation is in fact quite common and occurs if either the incoming information is absolutely new (yet unknown to the recipient), or certain pieces of

knowledge in the speaker's and the recipient's databases are inappropriately represented. It is clearly illustrated by a classic example of an artificially created message: *The Jabberwock* poem by Lewis Carroll ("*Twasbrillig, and the slithytoves Did gyre and gimble in the wabe...*"). None of its components (with the exception of prepositions and conjunctions) bears any semantic load (has any actual meaning), but certain syntactic relations seem to be present. Such collisions are resolved through dialogue between the recipient and the speaker.

It should be noted that communication may only function properly as a two-sided process if both communicants command a more or less similar set of linguistic means and cognitive potential for perceiving, understanding and reproducing symbolic patterns of communication. This status is achieved through education system, where children, on the one hand, are taught a more or less similar scheme of language structural organization, and on the other hand, are presented with a generalized world model which is *embedded in their memory* through schooling. In this case *figurative information is always handled by the linguistic processor first*, which decomposes the message into standard verbal structures, each of them reproducing a single quantum of knowledge. This research is mostly focused on the special aspects of processing verbal information as the major pattern of communication, even though real life communication systems are numerous and varied. First of all, let us analyze the peculiarities of perceiving and processing symbolic level information as the major model of acquiring and accumulating knowledge, and then let us proceed to analyzing the special aspects of perceiving figurative level knowledge.

This article is specifically concerned with introspective analysis of the process of information perception by the recipient (their individual speech system), taking into account the recipient's accumulated cognitive potential on both symbolic and figurative levels, based on the structural-functional level of language organization, as presented in this author's paper "Back to basics of speech activity" [4]. The major aspects of this view of the structural organization of speech are described below.

An important point to make is that modern information technologies aimed at processing natural language information are usually based on the achievements of classical linguistics, which, according to competent experts, still has numerous problem areas. This author has consistently formed an integral approach to analyzing the structural level of language organization, taking into account modern scientific achievements by experts from numerous borderline areas of speech research. As a result, a new approach to structural language organization has been synthesized, which is based on a single structure, clearly defined on formal level; and all the diversity of structural language organization is defined by using this structure on mono- or polypredicative level. It is a promising base for the development of a whole cluster of information technologies oriented towards processing natural language information.

## **2. Structure-functional level of memory neural organization**

So, after the personified cognitive feedback had been defined as the major model of acquiring and evaluating new information by a human being, the structure-functional level of human memory organization should be carefully considered, as it enables a human being to perceive, accumulate and store arbitrary information (*cognitive aspect*), and is also responsible for the communication process between a recipient and a speaker (*communicative aspect*) regarding speech realization, which ensures information transfer; it is a two-sided process of verbal message synthesis/analysis (or "speaking/understanding",

according to L. Shcherba [5]). *It should be noted that these two processes are dialectically united, are formed almost simultaneously and complement each other.*

The structure-functional diagram of human memory organization (Fig.1) introduced in the paper “Back to basics of speech activity” [4] is useful for analyzing both aspects of speech. In my opinion, this diagram covers both cognitive and communicative aspects of human speech, is based on modern research in numerous borderline areas and is itself a promising base for modelling one of the most complicated forms of intellectual activity – the verbal ability. What is more, the diagram covers the figurative level of information perceived by human sensory system (vision, hearing, touch, smell and taste) as well as the symbolic level of data transformation (speech, writing etc.), which not only performs the communicative function in a community, but is also *a powerful source for acquiring and accumulating new knowledge.*

### **2.1. The cognitive aspect of memory organization**

The major structure-functional peculiarities of human neural network organization can be defined on the ground of the materials presented in the paper “Back to basics of speech activity” [4] and summarized in the axiomatics of speech. Information about the environment is perceived, as shown in Fig. 1, by numerous sensors, each of them responsible for a certain level of environment perception. For the time being, the functional load of the visual analyzer is most fully analyzed, as it provides a human being with about 80 per cent of information. According to the results of neurophysiological research announced by Semir Zeki [7], the functional load of the visual tract can be quite clearly defined.

It is experimentally proved that the Figure-Ground separation is performed on the third layer of the retina (all *Obj/Subj* components of a specific situation are identified), the dynamics *Mov* of moving objects is identified on the 4<sup>th</sup> and 5<sup>th</sup> layers, the attributes of all detected components *Attr(Obj)*, *Attr(Subj)*, *Attr(Mov)* are further distinguished in the visual brain cortex, and then the measure *Attr(Attr)* of each attribute is estimated; all these tasks are performed automatically, completely and involuntarily.

**A similar functional load may actually be attributed to all sensory systems** – smell, taste, touch etc. Certain categories *Obj/Subj* may sometimes be distributed across time and space, and may only be clearly defined by their attributes *Attr(Obj)*, *Attr(Subj)* and the measure of these attributes *Attr(Attr)*. On the contrary, movement (*Mov*) may only be perceived by comparing discrete frames of perception. For example, the units of the visual sensor are saccades – coordinated eye movements grouped in time.

It is however important to note that a unit for recording both static and dynamic relations in the environment is a specific situation, and its extent is determined by a certain sensor of a specific type. Any sensor of the receptive field forms but a “copy” of a certain environment fragment (vision, hearing, touch etc.), and determining individual components and their attributes is the task for a specific analyzer (processor). This data is transferred to the neural network by a relevant nerve tract, stimulating individual neurons or neural ensembles and connecting them with associative links. This is how a fragment of neural network, which properly reproduces external stimulation, is formed in neuroglia. Attention should be focused on the properties of the created associative links regarding *two-directional* information exchange, which enables efficient communication. According to J. Hawkins’ testimony, presented in his book “On Intelligence” [8], all sensory systems have similar functional load, as cases are known when, after the receptors of one sensor had been damaged, another analyzer picks up the functional load of the damaged one.

It is however important to note that a unit for recording both static and dynamic relations in the environment is a specific situation, and its extent is determined by a certain sensor of a specific type. Any sensor of the receptive field forms but a “copy” of a certain environment fragment (vision, hearing, touch etc.), and determining individual components and their attributes is the task for a specific analyzer (processor).

This data is transferred to the neural network by a relevant nerve tract, stimulating individual neurons or neural ensembles and connecting them with associative links. This is how a fragment of neural network, which properly reproduces external stimulation, is formed in neuroglia. Attention should be focused on the properties of the created associative links regarding *two-directional* information exchange, which enables efficient communication. According to J. Hawkins’ testimony, presented in his book “On Intelligence” [8], all sensory systems have similar functional load, as cases are known when, after the receptors of one sensor had been damaged, another analyzer picks up the functional load of the damaged one

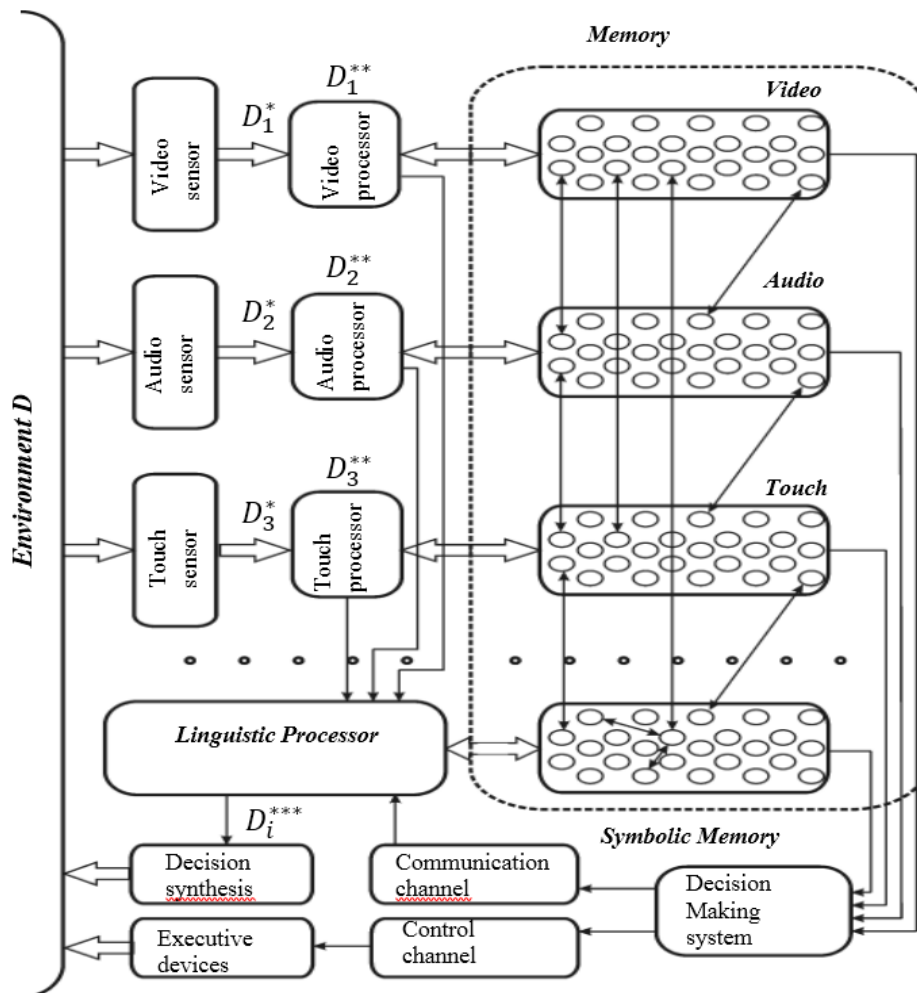

Fig. 1. Ageneralizedschemeof personal cognitive potential development and use

$D$  – the environment,  $D_1, D_2, D_3, \dots, D_n$  – information allayers of environmental perception  $D_1^*, D_2^*, D_3^*, \dots, D_n^*$  – sensory level of information perception,  $D_1^{**}, D_2^{**}, D_3^{**}, \dots, D_n^{**}$  – figural level of information perception,  $D_i^{***}$  – symbolic level of information management



So, it may be reasonably considered that from the functional point of view all sensory systems perform similar functions (even though a visual image is not equal to an image of taste or smell), but on the level of forming a generalized object description in deep brain structures all data from various sensors are converted to a single standard (*neural*) format, allowing the subject to manipulate diverse information in a similar manner. It is most important that diverse information about the environment, which is simultaneously perceived by various sensors and defined in the tri-unity of time, space and action, in human neural substance (neuroglia) is connected by numerous associative links, which, in general, properly reproduce a specific fragment of the environment. It is actually a generalized model of forming individual environment components, which is realized on the figurative level. In fact, *human memory contains specific fragments of reality in the tri-unity of time, space and action*, which include knowledge of both sensory and symbolic levels, *for all the living space*.

It should be noted that symbolic (verbal) information is received by the knowledge base in a similar manner. However, verbal information is processed a bit differently. When an individual word is perceived, a relevant memory node is stimulated (if such node already exists), and its associative links are used to form the semantic load of the word (its lexical semantics), which forecasts the possible scenarios of the further incoming message. This process is defined as “*personified cognitive feedback*”, when each message element is compared with the available memory potential, forecasting the possible variations of message continuation. This procedure determines the process of message “*understanding*” when its components are perceived. Let us remark that even when a message has not been processed yet, each word (in written or spoken form) is identified by the analyzer as an individual neural ensemble, and later this ensemble becomes a separate element in the neural network.

A break in knowledge continuity (lack of associative links in memory) with respect to any of the coordinates (time, space, action or other attributes) represents a new fragment of knowledge. If the same fragment of reality is perceived again after some time, we can clearly (to the finest detail) record all that had been changed, provided that the changes were somehow realized in the neural network, and memorize the new variation of this fragment without discarding the previous one. This leads to an important and useful conclusion: *human memory can only accumulate knowledge, recording all changes without losing the previous acquisitions, which are important for the person*. So, it can be stated that a specific environment model (in the general living space it is the *world model*) is formed within our memory on the figurative level, taking into account the tri-unity of time, space and action. This model is preserved lifelong and is constantly corrected and expanded with new data.

## **2.2. The communicative aspect of speech**

Neither a person nor any living creature can exist without a formed and functional communicative system, as this is what enables raising a new generation and ensures its survival in a rapidly changing environment, where swift adaptation is necessary.

The process of evolvement and formation of the symbolic form of environment representation has been rather clearly presented by this author in BICA-14 [4], based on A.N. Gvozdev’s meticulous and detailed observations on language acquisition by a child, by example of his son Eugene. When this data is arranged in chronological sequence, a clear progression becomes obvious for the major stages of language acquisition by a child in the process of verbalizing a certain situation of the visual environment. It should be

noted that the start of language acquisition is a child's "*communicative intention*" [9]: the desire to communicate with other members of the community, supported by an ability to use language on the acoustic level, which is formed as early as at seven months old, and the opportunity to receive certain material rewards (first of all food) and moral encouragement by means of communication.

The paper BICA-14 [4] endeavored to transfer the unsystematic knowledge of structural language organization available from the classical linguistics to the conscious formal level. The major five stages of language acquisition are clearly described in the paper, and it is shown that a child has fully mastered the standard verbalization pattern for a certain situation, that is *a basic symantico-syntactic structure (BSSS)*, by the time she is 3-4 years old. According to children's language researchers, by this age a child becomes "*a professor in linguistics on the level of everyday language*". It should be noted that the BSS structure is closely related to the concept of a situation (a fragment of the visual component of the environment), which is clearly defined on the notional, graphic and formal levels and includes up to seven/ten objects.

It is in fact the *monopredicative* level of language acquisition, where the message structure only describes one specific situation. By the school age a child has mastered the *polypredicative* level of message formation, which is based on the BSSS (the system of predicative and situational relations in particular) and opens up the possibilities for fluent communication, reaching the recursive message structure for both analysis (understanding) and synthesis (speaking) of a message. For a fusional language, unlimited possibilities for message synthesis become available, as a single BSS structure (for fusional languages) may be realized by billions of variations. The major stages of the language acquisition process are as follows:

**The sequence of structures acquired on the monopredicative level:**

- a single component message which represents a specific situation;
- a two-component message which represents the dynamics of the object/subject in the situation;
- a three/four component message, which includes additional components of the situation (time, space, cause, effect etc.);
- the previous structure is supplemented with predicative relations, which define the predicator (verb) patterns;
- attributive level of the components is added to the message.

This sequence of stages defines the formation of the basic semantico-syntactic structure as the basis for language structural organization as a whole.

**On the polypredicative level:** a child (a human being) acquires recursive message patterns based on a set of standard BSS structures. When the monopredicative relation system in the form of the BSSS has been acquired, a message can be organized by a recursive pattern, when a certain monopredicative level component is replaced with an entire situation, where vacant slots can again be occupied by entire situations, and so on.

Speech realization (both in message synthesis and analysis modes) is the responsibility of the *linguistic processor (LP)* of the individual speech system. When a message is being analyzed, the recipient's LP performs *message decomposition into standard BSS structures* (full or simplified as the case may be) among the unlimited variety of verbal message variations (on the subconscious level, in fact). This process defines (ensures) understanding a message, which is divided into individual standard structures.

When a message is synthesized, the process is reversed: among numerous stimulated neurons (or neural ensembles) the linguistic processor (left hemisphere of the brain)

chooses a certain fragment of stimulated neurons, applies a standard BSSS mask as a set of functional relations and (provided they are coordinated) responds to a query by forming a specific quantum of knowledge as a sequence of BSSSs.

Metaphorically, I have once explained this process to my students as follows: a “*linguistic goblin*” who lives in the LP has only one stamp: a BSS structure, and he stamps each message, in both synthesis and analysis modes, by the same structure. This is an answer to a very important question: why, not knowing (often not realizing) how the language is organized, can we speak the language fluently? We can do this because a single clearly defined BSS structure, used on monopredicative or polypredicative level, is all we need for any instance of language use (synthesizing or analyzing a message). Stanislaw Lem’s far-sighted words come to mind: “*Just like gravitational field limits the movement of bodies, the “language field” limits the trajectory of phrases*”. In our case, this may be interpreted as follows: “*just like the force of gravity determines the trajectory of a moving body, the BSSS (as a language standard) determines the peculiarities of message formation on the monopredicative or polypredicative level*”.

It should be noted that personified cognitive feedback is located and realized in human neural network, whose status and operation are unavailable to us yet. However, the results of such interaction between new information and the accumulated knowledge potential may be clearly traced by a person’s actions or speech. Cognitive and communicative processes are dialectically united in human memory; they are formed and developed simultaneously and are realized in human neural network in the modes of verbal message synthesis/analysis or thought, not necessarily verbalizing the results. Let us further consider only the verbal display of this activity, relying on introspective experience.

Obviously, the results of this interaction can only be observed indirectly – *on the verbal level, recorded in actual displays of speech*. So, the above mentioned processes may only be explored through individual introspective analysis of informational processes, which are realized on the verbal level (as reports regarding decision making processes, logical analysis of deduction chains etc.) Consequently, thorough analysis of human speech is the key to analyzing the processes associated with the PCF, starting with the notion of an individual speech system, introduced by L.V. Shcherba [5].

### **3. Integral approach to structural language organization**

Considering analysis of human speech, our main point of interest is operation of a fragment of cerebral neural substance responsible for perceiving and processing both figurative and symbolic information. This includes, at least, structure-functional organization of the acoustic analyzer (synthesis/analysis of spoken language) and the visual analyzer (synthesis/analysis of written and printed language), which belong to the right hemisphere of the brain, as well as a fragment of the left hemisphere responsible for logic, thought and speech. To sum up, it is clear that large fragments of human neural network located in both hemispheres are responsible for speech realization.

#### **3.1 Structural organization of the individual speech system**

The subject matter of the research (see Fig.2) is the *individual speech system*, which is defined as a combination of a person’s competence regarding language organization (*the linguistic processor – LP*) and the current cognitive potential on the verbal level in the knowledge base (*the knowledge base – KB*), according to L. Shcherba [5]. The linguistic processor is responsible for the processes of synthesis/analysis of an arbitrary message on the symbolic level, while the knowledge base integrates information of both figurative and symbolic levels from the whole living space.

It should be noted that the knowledge base as described by L. Shcherba is the whole current knowledge potential of “*verbal material*”, gathered in all printed and written editions. However, in our interpretation this accumulated potential of verbal material is complemented with human experience on the figurative level, received from all sensory systems. Modern neurophysiological research clearly outlines the structure-functional level of the processing system for visual information, as described by this author in the paper “Back to basics of speech activity” [4]. Essential conclusion of the above mentioned paper may be narrowed down to axiomatics of speech. For further research of communicative organization, the following basic notions seem important.

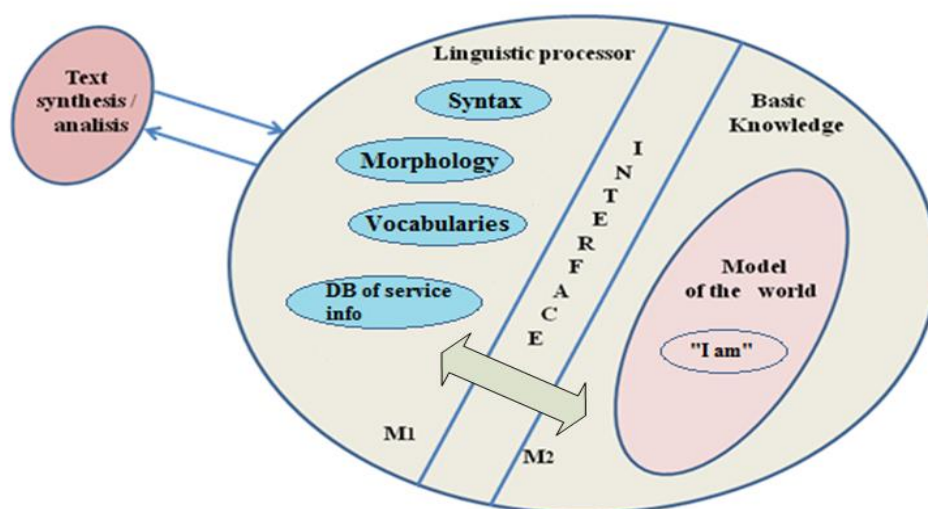

Fig.2. Individual language system

*The Linguistic Processor contain all knowledge about language organization, providing the processes of message synthesis/analysis. The Knowledge Base accumulates all the aggregate knowledge of both symbolic (verbal) and sensory levels. The Interface is the model of LP-KB interaction.*

1. Contemporary views on processing visual information, as quoted by Semir Zeki [7], are as follows: the visual analyzer on the level of the retina performs the Figure-Ground task for a specific image fragment which reaches the retina, defining all objects and subjects; besides, it involuntarily determines all attributes of the defined objects and subjects and the measure of these attributes. A set of individual components which *exist in the tri-unity of time, space and action* defines a specific situation, which includes up to seven (plus/minus two) objects. *A situation is a fragment of the visual environment which reaches the fovea centralis of the retina and is fully processed.*
2. According to J. Hawkins' conclusions presented in his book “On Intelligence” [8], all other sensory systems (hearing, taste, touch etc.) basically operate in the same manner, identifying certain stable formations of the relevant origin (Obj/Subj) and determining their attributes Attr(Obj/Subj), as well as the measure of such attributes Attr(Attr). It is a resourceful base for researching human sensory systems with regard to informational point of view. It should be noted that simultaneous stimulation of individual neurons or neural ensembles (independently of the sensory system) causes associative links to form in *neuroglia*, connecting individual components of symbolic and figurative information

into a single entity. Exactly how this happens in the neural substance is a question yet unanswered by neurophysiologists.

3. In the course of language development, a pattern for adequate translation (*verbalization*) of a specific situation from the figurative onto the verbal level has been gradually forming and developing. It is a very long-term process of the development of language as the major means of communication for humankind. Since the major language function is adequate representation of the real as well as virtual world, formation of new verbal means is subordinate to adequate representation of specific categories for an arbitrary situation.
4. Therefore, it should be specifically noted that each living community (population) has to create relevant communicative (verbal or otherwise) means for adequate reaction to stimuli of the fast-moving dynamic environment in order to survive in this rough and inconstant world. I strongly believe that no population in the world can exist and adapt to the dynamic changes of the environment without its own communicative system.
5. When a population has created and developed its own specific means of communication (not necessarily verbal), the above means are used for communication between individual members of the community. The only distinction between humankind and other living creatures, gained over long and hard centuries of evolution, is *the invention of symbolic data representation, which allows humans to record and accumulate cognitive assets of an individual as well as a whole community for the length of time far exceeding the lifespan of an individual*. This is what enables continuous accumulation of cognitive potential not only for an individual human being, but for humanity as a whole, and determines the fast technological development. Whether this benefits the humanity's survival is an open issue, especially in the era of computers and information technology.

### **3.2 A Basic semantic-syntactic structure as a single quantum of knowledge**

Since a specific figurative level situation, which exists in the tri-unity of time, space and action, is a unit of environment perception (considering that the figurative level is a human's main and most important channel for receiving information), relevant verbal means are needed to adequately represent these major categories on the verbal level. Formation and development of verbal means which represent environmental relations have been thoroughly analyzed in the paper "Back to basics of speech activity" [4]. A specific situation is represented on the verbal level by a basic semantico-syntactic structure (BSSS), which is defined on the semantic, graphic and formal levels. A graphic interpretation of the BSSS is shown in Fig. 3, where all components Subj, Obj, Pred are clearly defined; they are connected by two groups of relations:  $R_i$  and  $r_j$ . On the formal level the BSSS may be represented by means of Boolean algebra.

On the semantic level the BSSS is defined as follows: *a basic semantico-syntactic structure is a two-component monopredicative description pattern for an arbitrary situation in the real or virtual world, all components whereof are realized on the attributive level*.

Since the BSSS adequately represents a specific figurative level situation which exists in our environment by verbal means, and specifies the coordinates of time, space and action, the BSSS may be considered a single *quantum of knowledge* on the verbal level. Furthermore, if the BSSS is a single quantum of knowledge on the symbolic level, and is equivalent to the represented situation, we have reasonable grounds to believe that a connected set of individual situations represents a certain fragment of knowledge.

Therefore, a powerful conclusion may be drawn that *the national language knowledge base is clearly structured by uniform BSS structures.*

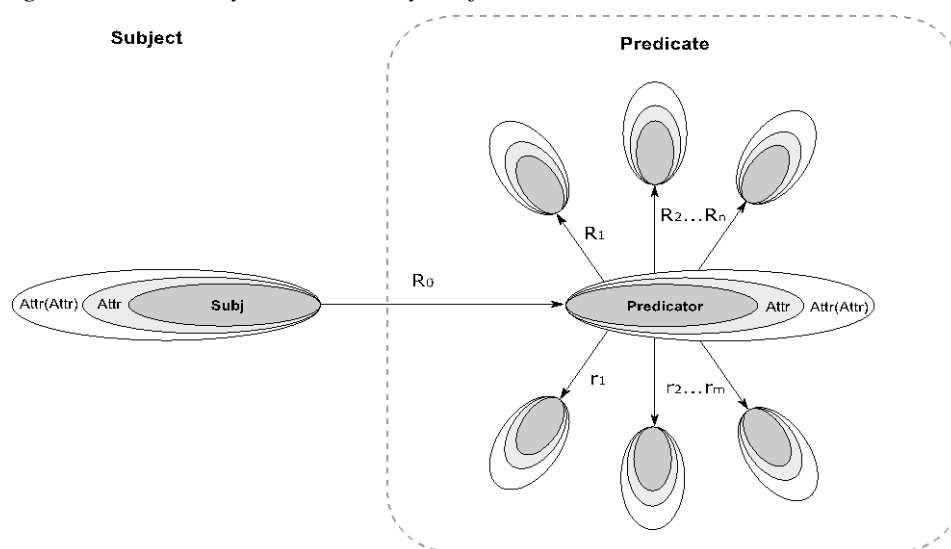

Fig. 3. The basic semantic-syntactic structure

*Subj* -BSSS subject, *Pred* – the verbal core of the predicate *P*, *R*<sub>1</sub>,..., *R*<sub>*n*</sub> - predicative relations, *r*<sub>1</sub>,..., *r*<sub>*m*</sub> - situational relations, *R*<sub>0</sub> - the major relation «to have a predicate».

This conclusion is based on long-term experience of decomposing arbitrary texts into BSS structures by students. This procedure had first been practiced by analyzing prosaic texts; for example, one sentence from “The Idiot” by F.M. Dostoyevsky includes about twenty uniform (full or simplified) BSS structures. Later this method was transferred to analyzing poetry, and in numerous cases convincing results were obtained. This procedure is well received and widely used by translation students as well as by information technologies students. It may be considered a good basis for automatic processing of verbal information.

#### 4. Realization of the personified cognitive feedback from an introspective point of view

Personified cognitive feedback is in fact defined by the pattern of interaction between new information perceived by a human being (not limited to the verbal level) with the current knowledge potential accumulated in the KB. Let us recall that the content of the KB (on the verbal level) is represented by an interrelated set of standard BSS structures, and various scenarios of information perception exist: after the linguistic processor has identified a new quantum of knowledge lacking from the KB, it is incorporated into KB content, or a KB fragment with the already known information is activated (if the new information is fully identified with KB potential), or a KB fragment is complemented with a new component, and a new quantum of knowledge with a relevant marker is formed. A set of figural level situations is incorporated into the KB in a similar way: a separate situation is added, or a fragment of the KB is complemented with a new component, or its dynamic properties are adjusted.

It should always be kept in mind that in case of a subsequently activated known situation it will be fully identified in memory if at least a certain part of the figural level corresponds to its neural correlate, since the whole imprint is immediately activated via relevant associative links in neuroglia. This process is defined by *the peculiarity of personified cognitive feedback realization*. Should any discrepancies be present, they are recorded on the previous imprint by way of forming new associative links, however using different markers: space and time, cause

and effect, dynamic etc. This results in variations of the situation description in different space and time coordinates, where dynamic changes are recorded. Therefore, the figural level is defined by adequate representation of a set of situations, as determined by the need for adequate perception of and reaction to dynamic situations.

#### 4.1 Peculiarities of PCF realization for figural level information

Let us analyze the figural level of information perception in more detail. It should be noted that each sensor operates discretely, with a unit represented by a separate discrete – a situation similar to a visual one, processed (with reference to Semir Zeki [7]) in full with all components identified: Obj, Subj, Mov, a set of attributes for each of them: Attr(Obj), Attr(Subj), Attr(Mov) as well as the measure of these attributes: Attr(Atr), Attr(Atr), Attr(Atr) (see Fig.4).

Jeff Hawkins [8] has generalized the aforementioned functional load for the whole sensory system, even though the objects of taste and smell are distributed by character and are mostly defined through the attributive level. Certainly, for the senses of taste, smell and touch the Obj component is distributed in time and space, but the totality of its separate attributes points to a certain stability of their existence, with a rather limited choice of verbal means for their identification.

It should be noted that for each moment (saccade) of observation of a separate situation in a certain interval of time all elements of the separate situation with their full attributive surrounding are recorded and memorized in the neural network (on the set of neural ensembles), as well as linked by association, since they are simultaneously activated by the given situation. It should however be emphasized that a neural imprint of a certain situation may include both new and previously involved environmental components at the same time.

It should also be taken into account that all levels of information perception and processing: verbal (symbolic) and figural (smell, taste, touch, visual and acoustic) are interrelated in the KB. One more peculiarity of the sensory information perception should be noted, which has already been published as a thesis: *each component of the environment (an object, a subject or a situation as a whole) is memorized in the neural network unchangeably (recorded in the triunity of action, time, space and other coordinates), and all the following transformations or changes will be identified with a different coordinate set with relevant markers*. Owing to this separate situation component may be recorded in their dynamics and development while keeping the initial presentation intact. If a certain set of visual situations is defined by consequent saccades triunited in space, time and action, they should also be interconnected in the neural network by a set of associative links which adequately represent a certain fragment of the environment. Neurophysiologists have yet to discover how these formations are identified in the neural network.

Let us recall that on the level of processing the figural component of the environment information that is generally used for certain everyday household actions is often perceived and accumulated, and it does not need to be translated onto the verbal level; however, under certain conditions (for example, during master classes) this stock of figural level knowledge may be verbalized and translated onto the language level.

Let us take a step away from analyzing the process of information reproduction in the neural network limited to a separate situation, and consider the peculiarities of information perception and accumulation on a larger scale, dealing with large fragments of the environment. Two models of sensory information recording and incorporation into the neural network seem important therein.

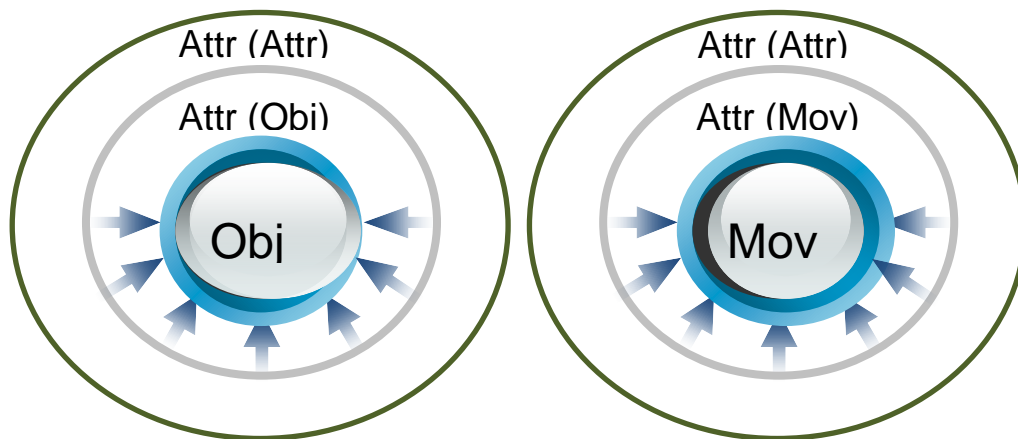

Fig.4. A generalized scheme for the Obj, Subj components of arbitrary information. *Obj*-object/subject category, *Mov*- motion category (dynamic component), *Attr(Obj)*- object attributes, *Attr(Mov)*-motion attribute, *Attr(Attr)*-attribute measure.

#### 4.1.1 Egocentric model of environmental scanning

Whenever an observer comes across new environment, they need to record and memorize the environment for orientation, scanning and learning. How does it happen? Let us consider certain aspects of the following standard situation: an observer gradually scans the environment, embracing 360degrees starting from their initial position and visual direction. Taking into account the aforementioned structure-functional organization of the visual tract, the process of environment perception by a human being can be described as follows.

Since the efficient angle of environmental scanning is  $15^0$ , at least 24 situations (360/15) have to be recorded and memorized for a circular diagram, discounting possible eye fixations on any artefacts of interest. It should be noted that each frame (as a separate situation) is thoroughly processed by the visual analyzer, with all components, their attributes and space-time properties identified.

However, with due account for the peculiarities of reproduction of frame sequences in the neural network, this process may be compared to creating panoramic images in photography. Even though panorama merge in Photoshop is implemented well enough, the corresponding process in the neural network is absolutely different, as each element of the environment with all its attributes is represented by one “copy” only, and *separate components are neither duplicated nor divided*. We have retraced the process of imprinting a separate situation, and the panoramic imprint of the environment is created by a sequence of such situations.

Let us examine how this imprint (a model of spatial section of the environment with an observation center in the subject’s location) is used. When a subject repeatedly finds him/herself at any spatial coordinates of the panoramic environment and observes their surroundings from a certain perspective, the very first object which is perceived by the visual tract and has a corresponding imprint in memory is identified as an element of the panorama recorded in memory; so, the whole panoramic imprint is activated via relevant associative links and the observer knows and understands what the next frame may contain, thus forecasting the environment and therefore their own behavior. This is how



personified cognitive feedback helps a person to adjust their behavior with regard to changing environmental conditions. It should be noted that even though environmental scanning is analyzed here on the example of visual information perception, the same applies to the sensory system as a whole.

#### **4.1.2 Object-central model of environmental scanning**

Analyzing the process of perceiving rather large objects by a human being by way of scanning them fully around the perimeter sets another task. The problem is that the object of analysis may not be fully identified by a subject within a separate situation, and its full visual “portrait” is formed by a sequence of images which embrace its separate fragments. However, a full image of an object of interest may only be obtained by its external investigation. Nevertheless, the process of forming a full object image in the neural network is similar to the previous example of egocentric perception and reproduction of the environment. A complicated object is represented on the neural level by a linked set of separate situations, each of them defined by its own unique markers of the triunity of time, space and action, and each component complemented with attributive elements. As for separate situational cognitive fragments, they are interlinked on the associative level by a set of component imprints for a specific situation, which are neither duplicated nor transformed over time, making automation of these processes rather problematic. However, adjacent frames are linked via separate components, which have already been identified in the previous frame and are not re-identified again.

If this fragment of the subject’s memory in their neural network is addressed again via observation or on the symbolic level (in the *mode of personified cognitive feedback*), a certain fragment (certain details) of the object image is activated, whose associative links activate the whole fragment of the neural image of the specific object. So, the whole image of the object is activated by separate fragments of its neural image, and the following subject’s actions are forecasted. This phenomenon was noticed by researchers a long time ago and may be identified as the “*holographic memory effect*”. The important difference between technical systems and the human memory is that the above mentioned effect is limited to the data recorded on the film in the first case, but expands to all the memory span in the human neural system.

Overtime, a certain scenario for further development or completion of a certain object (not yet fully scanned) may be forecasted from the imprints of its fragments. If this object is unfinished or has been destroyed, this forecast proves rather accurate. These virtual constructions confirm the existence of an interrelated sequence of imprints of the previously seen situations, triunited in the previous coordinates of time, space and action in the human neural network, which make it possible to forecast congruent human behavior in the real environment.

A combination of the egocentric and object-central models of environmental scanning as described above make scanning, memorizing and orientation in arbitrary real-life situations possible, including complicated labyrinths, city catacombs etc. The continuous character of environmental scanning forms an adequate memory reflection of anything seen, no matter how complicated, and ensures its full activation in the neural network by a slight fragment of the whole. This makes forecasting and adequate reaction on the slightest dynamic signals from the environment possible. This *forecasting effect of the personified cognitive feedback* may be observed in numerous real life situations.

If a known situation is activated repeatedly, only a part of the figural level needs to correspond with its neural correlate for its full identification in memory, since the whole

imprint is activated via relevant associative links in neuroglia. This process is determined by the *peculiarities of personified cognitive feedback realization*. If any discrepancies are found, they are recorded on the previous imprint by way of forming new associative links, but with different space and time markers. This results in different variations of the situation description at different space and time coordinates, where dynamic changes are recorded. Therefore, the figural level is determined by adequate reproduction of a set of situations, which is caused by the importance and necessity of adequate reaction on the dynamic environment.

So, both aspects of processing visual data (and, possibly, any sensory information) share a common peculiarity of *adequate* reproduction of environmental relations in the trinity of time and space coordinates and their dynamics in the neural network. This means that a set of separate sequences (frames) is formed in memory, which are *interlinked* to make a larger cohesive picture on the level of separate components or a set of components.

#### **4.2 Peculiarities of personified cognitive feedback (PCF) realization for symbolic level data**

Structural organization of the symbolic level data has much in common with figural level data processing. The only difference is that information is presented in symbolic form, which is often connected with components of the real life figural level via associative links in the neural network, provided that they have been recorded. However, it should be noted that the systematic approach to analyzing the structural level of language organization implies analyzing the correlation between Reality and Text, where a unit of reality perception is a separate *situation* in the visual component of the environment, and a *BSSS* as a verbalized (textual) form of reproducing a situation is structurally derivative from the structure-functional level of the visual tract neural organization.

Nevertheless, human sensory system has been formed throughout the evolution of perception of environmental aspects and life space organization, while the knowledge of the environment has been gradually expanding together with the habitat, starting from a certain lake or river on to a continent and – recently – even to the outer space. Therefore, the knowledge accumulated by humanity goes beyond immediate contact with the living space; entities are observed, analyzed and used which exist beyond human sensory perception. In fact, a *virtual world* is formed, which lies beyond immediate perception; however, *a model of this world is based on the foundations and realities of the existing environment*.

It is clear that every person has their own model of this virtual world; however, varying research of the macro/micro world with the help of powerful technical equipment which greatly enhances the abilities of human sensory systems has formed or is forming fragments of knowledge which define the general knowledge, theories and convictions beyond our real living space. It should be noted that results of scientific research and experiments are the major source of this knowledge, and human language is the major channel of its distribution as well as of educating the new generation. However, exceptions to this rule exist, since human imagination may go beyond real life canons. A good example is *Solaris* by Stanislaw Lem, where a whole planet, not a person, appears as an intelligent being.

##### **4.2.1 Correlation between the real and the virtual worlds in neural system**

Let us analyze the correlation between the processes of reproduction in the neural system for the real and virtual worlds. While the basic principles of communicative level formation are determined by the standards of the real environment where a person was born, educated and mastered language, their cognitive level is associated with the

circumstances of life, environment, education, scientific research etc. The left half of human neural substance is associated with the stages of language mastering and formation on the basis of perception and reproduction of the real environment by an individual's sensory system. Therefore, each population has formed a relevant sensory system during its long evolution both for acquiring knowledge about the environment (cognitive potential) and for creating communicative level for the purpose of education and transfer of experience to future generations via relevant communicative means.

Certain matters of principle that have emerged in the process of language research should be emphasized. These aspects may be clearly defined as follows:

1. on the cognitive level of neural network, the scope of knowledge identified with a certain situation may be regarded as a separate "*cognitive puzzle*" – an element of the figural level, which together make up a certain fragment of knowledge;
2. the cognitive puzzle is transferred to the communicative (verbal) level as a separate BSS structure (with the observer's intent), which may be considered a "*communicative puzzle*";
3. it should be noted that associative links between the corresponding elements of the figural and communicative levels are formed at the stage of language development (when a child is 2-3 years old) [9] and last throughout lifetime, provided that new (yet unknown to the subject) elements of the environment are learned;
4. a unique aspect of human memory should be emphasized: *a limited number of specific elements of the neural network (Obj, Subj, Mov) may be used to perceive and record avirtually unlimited number of situations* (cognitive puzzles) which are identified by different markers in the triunity of time, space, action and other attributes;
5. In general, the number of cognitive puzzles perceived and formed by human sensory system (sight, hearing, touch, smell, taste) greatly exceeds the number of verbalized (communicative) puzzles.

It should be noted regarding the suggested terminology that nowadays the term *puzzle* is widely used in numerous professional spheres and has gained a rather stable semantic load as *a part of the whole*. In our case, however, the term *puzzle* refers to a certain fragment of the neural network responsible for perceiving and recording a certain situation on the figural or symbolic level, interlinked by two-way associative links.

Each cognitive puzzle is realized in the neural substance on a set of separate neurons or neural ensembles necessary for reproduction of a separate situation on the level of a set of components (7 plus/minus 2) as well as their attributive surrounding (see Fig. 3). The content of each puzzle (according to Semir Zeki [7]) is determined by a certain situation with all components (Obj, Subj, Mov) realized on the attributive level; a structural bond inside the puzzle is realized by a set of associative links in neuroglia; links between puzzles will be determined by the associative links formed in the neural network when a certain element of the previous puzzle is activated simultaneously with new elements of a new activated puzzle. As opposed to technical implementations where separate puzzle pieces are cut by a formalized pattern (disregarding the content or semantics of the image), *the cognitive (figural) puzzles are divided on the level of associative links, with the cognitive load of each puzzle kept intact and without breaking the integrity of separate components (Obj/Subj) of each puzzle, taking into account their attributive surrounding*. A cognitive puzzle is solely realized on the figural level. However, the structure of the communicative puzzle is defined by the BSS structure (Fig. 3) and is realized on the verbal level while keeping the components as well as the relevant links intact.

One more argument for picking a puzzle as a discrete element of environment perception is that *a situation* (according to psychologists and neurophysiologists) covers but a tenth part of a separate environmental fragment which reaches the retina at a given moment. So, for thorough investigation of the whole fragment of the environment, triunited in time, space and action, at least nine figural puzzles – situations have to be consecutively investigated (which happens automatically), and relevant communicative puzzles in the form of a set of BSS structures have to be formed, if necessary. *For a written text, this interconnected set of puzzles is defined within a paragraph.*

Up till now, the peculiarities of Personified Cognitive Feedback realization have been analyzed for figural and verbal levels solely as models of perception and processing of quanta of information, defined as *puzzles*, which cover certain environmental situations. However, the author's research on the system organization of language, which has been conceptually presented by BICA-14 [4], provide tools for analyzing the process of PCFB realization much more thoroughly, specifically for symbolic level information. The major conclusion of this research is that any text or arbitrary message is presented by only one verbal standard – a BSS structure, which may be used on the mono- or polypredicative level. This provides detailed insight into the peculiarities of PCFB realization in the process of verbal information perception, as its structural organization is clearly defined.

It should be kept in mind that the figural level generally takes priority over the verbal level, and certain components of different puzzles may be interconnected via associative links. Nevertheless, rather often (when the need arises) a cognitive puzzle of the figural level is transferred onto the communicative level as a BSS structure in order to take part in the communication process. However, A.N. Pertsov's [10] note that "*pragmatics of a word is but a pale shadow of the pragmatics of an image*" should always be kept in mind, therefore, on the symbolic level a communicative puzzle is just an outer shell for a cognitive puzzle. Neurophysiologist Academician Kryshchal O.O. [11] explains this brilliantly by metaphorically defining the process of thought as "*a light wind of ions in the crowns of neurons*", since information is known to be carried by sodium and potassium ions. So, the figural level of data presentation is much more complete than the symbolic one, where *a word triggers the activation of all the variety and abundance of the figural level information*. So, let us limit our further studies to the symbolic level information in our memory in the KB. This identification of specific peculiarities of cognitive and communicative processes provides the basis for more specific analysis of the processes of environment perception, accumulation of information in human memory, its transfer onto the verbal level and use in the field of modern IT.

Regarding the scheme in Fig.1, it should be noted that the virtual world (in certain scientific fields, logic, mathematics, astronomy, physics, certain imaginary creations etc.) is formed by the standards and laws of real life environment perception and its reproduction via verbal means. However, *in this case the objects of research are certain virtual entities, projects, hypotheses, research trends etc.* They are often outlined with one name, but the object of research itself is identified a set of its attributes, peculiarities etc. Separate situations are defined by the set of their components, triunited in time, space and dynamics.

#### **4.2.2 Peculiarities of PCF realization in an individual language system**

Cognitive feedback is actually defined by the pattern of interaction between new information, perceived by the linguistic processor of a person's individual speech system (Fig. 2), with the current knowledge potential accumulated in the KB. Let us start with a generalized model of formation and use of a person's cognitive potential, which is

simultaneously realized on the figural and symbolic levels, interconnected via numerous associative links. Certainly, at the moment only the symbolic level of information management is available for analysis, but in the general case the possibility of incorporation of both figural and symbolic levels into the KB should be taken into account, with both levels realized on the neural level of the central nervous system.

The general ideology of this memory organization is concisely presented by the axiomatics of speech in the paper “Back to basics of speech activity” [4]. We shall not touch on the figural level for the time being, but shall concentrate on the peculiarities of organization of the symbolic level. Taking into account the integral approach to language structural organization and delving into introspective analysis of speech (Lefevre A. [12]), the following version of knowledge perception, accumulation and management by the individual speech system may be suggested.

If a separate situation is a quantum of knowledge on the figural level, and its verbalization is realized on the symbolic (verbal) level by the BSS structure, it is important to trace the major stages of “*incorporation*” of the new quantum of knowledge (the BSS structure) into the recipient’s cognitive network for the purpose of modelling the process of knowledge perception and accumulation. In fact, we deal with *introspective analysis of the processes of interaction between new information and the accumulated KB potential of the individual speech system* for an incoming message. Let us one more time recall the important conclusion of speech axiomatics presented in “Back to basics of speech activity” [4]: *a set of figural and symbolic situations interconnected via associative links, each of them marked according to the triunity of time, space, action and other parameters, is stored on the KB*. Potentially, each figural level situation may be more or less adequately presented on the symbolic level via certain verbal means, but it is not always possible nor always efficient. It is well known that certain interdependencies are easier to explain on the figural (graphic) level than, for example, by words.

When a linguistic processor of a recipient’s speech system is addressed, this address is actually realized on the verbal (symbolic) level, which is much poorer than the figural one. So, let us further consider the symbolic level information, keeping in mind its correlation with the figural level. Since symbolic level information is represented in the KB by a set of interconnected BSS structures, let us consider the analysis of cognitive processes to be limited to the peculiarities of perception and processing of a set of such structures. According to the graphic interpretation of a BSSS (Fig.3), introspective analysis of processing a separate message falls into the following stages: addressing separate components of the BSSS, identifying situational and predicative relations, addressing the BSSS set as a separate fragment of knowledge. *A general peculiarity of this process is formation of personified cognitive feedback in the KB when perceiving a separate element as well as the whole BSS structure, which complement the cognitive potential.*

Dialectic interaction between the LP and the KB in the process of perceiving and processing a text should be noted: *the LP on the analysis stage uses the knowledge accumulated in the KB, and as soon as the current BSSS has been identified forms a new quantum of knowledge which is added to the KB potential and may be used for further analysis, but in the capacity of context. Actually, this LP – KB pattern of interaction between separate fragments of human neural substance is defined as personified cognitive feedback.* From the peculiarities of the suggested KB organization rather important fundamental questions arise: *how can an infinite set of separate quanta of information, represented by BSS structures, be reproduced on a finite set of KB nodes; and how infinite*

*inclusions of a word form into other quanta of knowledge (BSS structures) can be realized through one neural network node where it is coded?*

Taking into account the current rather limited knowledge regarding peculiarities of neural network operation and possibilities for memorizing and coding the triunity of time, space and action for a separate situation, these questions can be answered as follows: *each new quantum of knowledge, which passes through a certain node, creates its own unique new marker*, so that it can be used unambiguously every time when an equivalent quantum of knowledge is incoming, and when the information is slightly changed, the chain of markers representing associative links is also transformed. How this process is realized in the neural substance is yet to be discovered.

When each component of the current BSSS is perceived, the LP addresses a corresponding component of the KB, its potential semantic load on the set of associative links is read and returned to the LP, forecasting the possible versions of its continuation. This iterational procedure of interaction between LP and KB makes the process of text analysis possible, and generally determines the process of “understanding”. In this case the term “*understanding*” is equivalent to “*knowledge*”.

#### **4.3 Language as a powerful channel for acquiring and accumulation of knowledge**

So, cognitive and communicative processes are constantly realized in human neural network. Certainly, the communicative process may only take place on the cognitive background. Both processes are formed and realized in human neural substance. We can but speculate on how exactly this happens, but modern achievements in numerous borderline fields of speech research make it possible to make certain assumptions regarding organization and flow of these parallel processes in human neural substance.

According to the materials of BICA-14 [4] human neural network is powerful cognitive substance which is capable of acquiring information from various sensors of human sensory system, and, after it has been processed in the relevant areas of the cerebral cortex –visual, auditory etc., *transforming it into unified (neural) form of knowledge presentation, where interaction of different forms of knowledge presentation is possible*. The symbolic level of reproduction of arbitrary information actually fulfils a similar function.

It should be emphasized that information received from each sensor is discrete. So, all sensory systems may be anticipated to work identically on the structure-functional level. When a sensor has acquired some information about the environment, triunited in time, space and action, adequate memorization, reproduction and use of this triunity (within separate fragments of the cognitive component) may be metaphorically described as follows. The cognitive level of human neural network forms and accumulates lifelong potential (*cognitive soup*) represented on the figural level, where all life experience, which is structured in separate fragments of attention by the coordinates of time, space and action, is compressed. Let us recall once more that these categories are somehow materialized and recorded in the neural network and are stored as long as conscious life continues.

However, it may be considered that a communicative pattern for addressing the wealth of human memory has been gradually formed over the cognitive substance covering the figural level. According to children’s speech researches, this communicative pattern is formed by the age of 3-5 years, and fully matures by the age of 7-9 years (primary school age). By this age the communicative pattern of interaction, based on a separate BSS structure as a verbalized pattern for reproducing an arbitrary real-life or virtual situation, is fully formed. In fact, it defines the interrelation between cognitive and communicative systems. Certainly, operation of the communicative system is based on cognitive substance – the

cognitive soup containing figural level information (visual, auditory, olfactory, gustatory, somatic sensation) as well as symbolic information based on all the accumulated verbal level potential (books, magazines, communication – any displays of symbolic reality).

Children's speech researches unanimously claim that whenever a child aged three to five years is unable to master the structural level of language organization (that is, associate a certain real life situation with its verbal reproduction in the form of a BSS structure or a set of such structures), (s)he actually fails to become a productive member of society in respect of intellectual development.

The reason behind this is that *mastering language organization opens an important channel for acquiring arbitrary figural and symbolic information gained and conceptualized by the society, which in due course becomes a dominant source of new information acquired through reading, oral communication etc.*

It should be noted that cognitive and communicative processes are dialectically connected as they form and complement each other. The communicative level is forming during the first three to five years of life and becomes a major factor of the person's communication and development.

This is explained by Masaru Ibuka [13], an expert in child psychology who has been working with children for a long time. The conclusion is unambiguous: *at this age a child's neural substance is most flexible and, like a sponge, is capable of absorbing, memorizing and accumulating all knowledge acquired by the whole sensory system on the figural as well as symbolic levels, interconnecting them via associative links.* Language becomes a powerful cognitive level for creating and acquiring arbitrary information, permanently connecting it to the figural level information received from the sensory system.

It is well-known that a child who has not mastered the communicative pattern of acquiring, accumulation and management of information (especially its transfer from figural to verbal level) by the age of five will never become a productive member of society with regard to intellectual development. This might be explained by flexibility of the neural substance, which is no longer able to form a fully realized communicative system, capable of integrating knowledge of both figural and symbolic levels, in later life. In this context, B.Y. Horodetskyi's [6] opinion on language organization is to the point: *"numerous problems in linguistics are due to the fact that language is still regarded as a form of reproducing thoughts, not a scheme for knowledge organization and presentation"*. So, the fact that a person who has not mastered the pattern of verbal communication does not become a productive member of society with regard to intellectual development is justified. *This person has failed (for any reason) to master the system for acquiring, organization and (most importantly) transfer of any knowledge to the verbal level, this generalized pattern of knowledge organization and presentation, and therefore of communicative system development, in time.*

In this context an important difference between human and animal communicative systems should be noted. The thesis that any living community develops and uses some communicative organization pattern for its evolutionary development and survival has been mentioned here more than once. *What is the principal difference between a human being and an animal in this light?* Numerous experts have long been trying to answer this questions, but to no avail. Here B.F. Porshnev's "Problems of Paleopsychology" [14] are fitting to be cited, where the author outlines the current status of this issue: "Not only idealists, but numerous materialists as well are busy looking for the attribute which distinguishes a human being from an animal "from the very beginning" and to modern days. It is implied that this

sing leattribute exists. It is also implied that the purpose of science is to define this major distinction of humanity. *On the VII International Congress on Anthropology and Ethnography, which took place in Moscow in 1964, a symposium “A Line between a Human Being and an Animal” has been organized. Numerous specific distinctions have been outlined, but the general purpose of the symposium has not been fulfilled.”*

We can see that B.F. Porshnev has intuitively been right; however, this problem has been solved during one of the recent conferences on artificial intelligence in Katsiveli (Crimea, 2012), when three participants of the conference (an expert in linguistic technologies A.A. Chipashvily (Moscow), P.M. Denysenko (Kropyvnytskyi) and me – Y.I. Kyslenko (Kyiv) were discussing the problems of artificial intelligence in hospitable A. Chipashvily’s comfortable apartment, and touched upon this issue. The answer has been found unexpectedly and spontaneously, but in the course of time this solution proves more and more certain.

A human being has one developmental distinction from animals (which also have various communicative systems available): *invention of writing as one of the means of indirect communication Writing meant a possibility to store, present and transfer knowledge from one living neural substance to another for periods of time greatly exceeding its own lifetime and existence.* This stage is crucial for storing and accumulating information for future generations, which determines *accelerated technical progress* in particular and fast development of humanity in general.

In the course of processing these materials two more clear distinctions between a human being and an animal have been shaped: firstly, only the humans have ever created *artificial sensors* – instruments which greatly increase sensitivity of biological sensory systems, making investigation of micro and macro worlds beyond humanity’s living space possible (a microscope and a telescope); secondly, the technical progress has gradually provided a basis for the development of *global cognitive potential*, starting from manuscript collections and printed books storage in libraries to modern electronic data storage devices. The Internet is a system open for all members of the community to acquire and submit knowledge freely. All in all, *a human being is different from an animal by the following three aspects: invention of writing, creation of artificial sensory systems and development of a global knowledge base with free access for the whole community.*

### **5. Dominant and intuition as powerful implementors of PCF**

The concept of “*a dominant*” as the status of a separate fragment of the neural network dominating over all others has been introduced by O.O. Uhtomskyi in the early XX century [15], even though the term itself is borrowed from Avenarius’s “Critique of Pure Experience”. Since then the term has become common in the field of neural network research, and this concept has later become pivotal in his lifelong scientific endeavor. When certain parts of human brain are responsible for providing vital metabolic processes as well as for fulfilling cognitive and communicative functions (*neurons, neural ensembles, neuroglia as the environment where associative links are formed*), the influence of this condition on cognitive processes may hardly be overestimated.

#### **5.1. Uhtomskyi’s dominant**

O.O. Uhtomskyi’s research on the activity of human neural network and definition of the concept of “*dominant*” as one of the important features related to acquiring and processing new information provide some explanation for the peculiarities of personified cognitive feedback realization.



When it comes to analyzing cognitive processes related to acquiring information, any feedback may be considered positive with regard to accumulation of information, as has already been mentioned. However, different functional load of the neural network should be identified: on the one hand, it is the informational load which increases with time (positive cognitive feedback), and on the other hand, power load which is caused by intensified operation of the neural network and which always leads to loss of stability in engineering systems. *How may the second tradictory features of human memory (and biological memory in general) be connected?* This question is answered by an outstanding physiologist O.O. Uhtomskiy in his “A Dominant and an Integral Image” – 1924 [15].

The dominant is a general feature of central nervous system operation, which has proved very important for analysis and development of knowledge base design in modern information technologies. The general conclusion is that the dominant fulfils a function of a general principle of operation for nerve centers. For O.O. Uhtomskiy, the dominant defines orientation of human perception, which integrates feelings into a holistic picture. In our case, the following thesis by O.O. Uhtomskiy is important: “the dominant is a more or less stable focus of hyper excitability of centers, regardless of its cause; moreover, the excitation reaching the secenter sincreases (confirms) the excitation within focus, where a sinhibitl on is widely spreadin o the rparts of thc central nervous system”.

This peculiarity may be regarded as an explanation of the nature of information perception by the CNS. *On the one hand, accumulation of information indirectly via the dominant phenomenon is a positive factor for increase of cognitive potential with significant energy expended on excitation and formation of associative links in a separate fragment of the neural network, but on the other hand – due to limited power potential of the CNS as a whole energy expenditure for idle areas is reduced because of inhibition processes.* So, the following interesting relation is observed: *cognitive and power potential in excited CNS centers is increased at the expense of reducing energy expenditure in inhibited centers. As for the general energy balance of the neural substance, it remains more or less stable.*

And the last O.O. Uhtomskiy’s observation which is important for us: “*The dominant is likely to manifest itself clearly in other fields of brainwork, for example, when mental activity is concentrated on a certain scientific field*” [15]. In this context, it should be noted that I have now referred to O.O. Uhtomskiy after an almost half-a-century break, since my first interest in neurophysiology. The associative link between my postgraduate topic “System Organization of Memory” (1968) and the research by P.K. Anohin and O.O. Uhtomskiy was among the first ones that formed in my neural network, but it has survived till the present (2016) and has become an important basis for scientific research. *However, only in the course of recent research on the topic of personified cognitive feedback a recollection of the concept of dominant awakened in my neural network, which had somehow (via a half-forgotten and almost destroyed associative link) been realized in the context of scientific research, thus confirming (through repetition) and complementing my personal cognitive potential.*

In this context the novel *The Bull’s Hour* by Yefremov should be mentioned, where the following thesis is stated: *human neural network is most active from 3 to 5 a.m., while the major part of the CNS is at rest.* However, this peculiarity is greatly subjective by nature and depends on numerous factors. My personal neural network (*with regard to scientific research*) is indeed most active during this interval. Here B. L. Pasternak’s revelation, which has once deeply impressed me, is to the point: “*More than once I have observed that the*

*things hardly noticed at daytime, thoughts not quite clear, or words said without feeling and left without notice come back at night in flesh and blood and become dreams, as if to repay for their disregard". Why is that so? What is the reason for this relation?*

### **5.2. Functions of the brain at rest**

In the above mentioned context it is important to consider modern neurophysiological research regarding human brain activity during the period of twenty-four hours. A certain explanation for the phenomenon of brain activity during the periods of rest may be suggested by "The Secrets of the Brain at Rest". The thesis that activity of the nervous substance during the periods of rest is now testified is stated by this paper. Neurophysiologists have recorded activity of the neural network at rest, which includes five varieties. Let us emphasize the informational component only, leaving the processes of metabolism and restoration of physical activity aside.

The following important conclusions are of interest:

1. *The brain is more than capable of making decisions when sleeping; the brain follows its programs even during sleep;*
2. *The brain sorts memories, and during the periods of sleep new memories are processed and links with the old ones are checked;*
3. *When sleeping, the brain builds associations and finds links between seemingly unrelated things. This may lead to unusual ideas or profound understanding of the world. So, unexpected spontaneous ideas are in fact not so spontaneous.*

The reasons for this have not been explained yet. However, based on the materials of modern neurophysiological research and taking into account the peculiarities of the "Dominant" and "Intuition" processes in separate fragments of the neural network, the following explanation for increased brain activity during the periods of sleep may be suggested.

In our opinion, during deep sleep activity of the sensory system, which is localized mostly in brain cortex, is substantially decreased. Therefore, at night the power potential of CNS operation responsible for information processes, in particular, for incorporating the acquired information into personal cognitive potential, is significantly increased. So, *the most favorable time for efficient realization of personified cognitive feedback is the period when on the one hand sensory system is blocked out (most often it is the interval of deep sleep), and on the other hand the metabolic processes of the long day are completed in the CNS and the neural network is capable of actively acquiring new information.* Certainly, the periods of peak brain activity may vary and are individual for every person, but an average interval of increased activity probably coincides with "the Bull's Hour" (the interval from 3 to 5 a.m.) when the capacity of human neural network for processing new information and its incorporation into the person's cognitive potential is at its highest.

### **5.3. Intuition**

Finally, in the context of analyzing the cognitive process of new information synthesis the role of intuition seems rather important. Here the idea by a prominent philosopher Hubenko O.O. regarding the phenomenon of "intuition", which is also somehow related to the thought process, is to the point [16]. According to his definition, *intuition is a process of overcoming gaps in the continuity of the person's knowledge regarding some phenomenon or object, etc.* So, when trying to solve a certain problem or task a person *intuitively* (not fully realizing how) suggests a solution to the problem, indirectly *using other knowledge, analogies, similar models and principles etc.* Only after some time has passed and the relevant memory fragment has been repeatedly or potently activated by new knowledge, a rational bridge over this knowledge gap may form.

So, having analyzed the results of modern speech research in various fields, we are able to overcome our “*knowledge gap*” regarding this particular question and suggest a possible answer. It is also important to note that information in three capacities is combined in human memory: *sensory* (or *figural*), *symbolic* (on the verbal level) and *abstract*, which is formed in the virtual world and has no equivalent in the real world, or cannot be grasped by the limited human knowledge. But the cognitive potential of human neural network is always able to transmit information of any type onto the verbal level, after its communicative ability is formed (a language is mastered).

In the above mentioned context, I would like to share some detail about the working process on this paper. In the previous versions a chain of dates had been noted before each title, marking certain stages (*gleams of intuition*) of fruitful work, overcoming some problems on the way of research of new topics. This chain may be found below; it should be noted that all the “*gleams*” of new thoughts fall into the interval of The Bull’s Hour – from 3 to 5 am.

\* 20.08.14 \* 27.08.14 \* 12.03.15 \* 08.05.15 \* 30.06.15 \* 02.07.15 \* 07.07.15 \* 14.07.15 \* 27.07.15 \* 01.08.15 \* 09.08.15 \* 29.09.15 \* 3.10.15 \* 1.11.15 \* 25.11.15 \* 28.12.15 \* 31.12.15 \* 13.01.16 \* 22.01.16 \* 27.01.16 \* 03.02.16 \* 06.02.16 \* 10.02.16 (morning 4-6)\* 20.02.16 \* 21.02.16 \* 23.02.16 (morning 5-6)\* 12.03.16 \* 15.03.16 \* 19.03.16 \* 02.04.16\* 09.04.16 (6<sup>00</sup>) \* 10.04.16(8<sup>00</sup>) \* 13.04.16 (7<sup>00</sup>) \* 20.04.16(5<sup>30</sup>)\* 02.05.16 (4-5)\* 03.05.16 (7)\* 9.05.16 (6<sup>30</sup>) \* 10.05.16 (7<sup>00</sup>) \* 17.05.16 \* 27.05.16 8 \* 29.05.16 \* 11.06.16 (6<sup>30</sup>)\* 26.06.16 \* 27.06.16\* 08.07.16 \* 9.07.16 (5<sup>00</sup>, 7<sup>00</sup>) \* 10.07.16 (6<sup>30</sup>)\* 15.07.16 \* 10.08.16 \* 02.09.16 \* 16.09.16 \* 5.12.16 \* 11.12.16 \* 21.12.16 \*

Generally, this work has taken about two years. One comment to the above chain: *the whole time interval of the work is the time of evolvement, development and existence of the dominant of scientific research “Personified Cognitive Feedback”, which has actually marked the time of creative brainwork on the general topic, and each date of this chain means a certain work stage (a gleam of intuition), which was determined by overcoming a gap of continuity in my knowledge (and, certainly, solving some cognitive problems) on the difficult way of learning the new aspect of human neural network operation.*

In connection with the list of these dates, which mark the individual “inspirations of an insight of a new thought” in the direction of the study of SOP, one should publicize another fact: on February 24, 2018, from 6 to 7 am, at last, a clear principled position was reached regarding the architecture of the structural and functional level of the organization of natural- language knowledge base. In the general case, this is a two-level structure, where the first level is “kanva” - the basis for the formation of BZ in the form of only a set of individual tokens, taking into account all possible variants of use of each of them, and the second - a layer of cognitive level, presented by a bound set separate structures of the BSSS, each of which reproduces a separate quantum of knowledge of the language level.

Such an approach to the structurally functional organization of linguistic material was formed somewhere in the twentieth of February, in 2018, a group of like-minded people consisting of: Kislenco Y.I. - (project leader) and postgraduate students: Sergeyev D.S. (responsible for the structural and functional level of the organization of the Knowledge Base) and Khimich A.V. (responsible for the structural and functional level of the linguistic processor organization). However, this result already relates to the stage of collective elaboration of a certain dominant and the formation of a new contribution to the collective potential of knowledge.

It is important that this fact already confirms the principle possibility of practical use of the proposed approach to modeling the individual language system of a person as a dynamic scheme of interaction of the linguistic processor and knowledge base, which opens the perspective of solving Internet problems: Semantic Web and Data Base.

## **6. Personified cognitive feedback as a major drive for progressively accelerated development of the society**

It is time to draw some conclusions regarding development and operation of personified cognitive feedback and its influence on the development of the society. When I was beginning to work on my postgraduate paper “System Organization of Memory” in the institute of cybernetics (1968), I was impressed by B.F. Porshnev’s fundamental thesis: *the history of humankind is a progressively accelerated process*. A question arose: why is it accelerated, moreover, *progressively* accelerated? This verdict had some unknown and incomprehensible magical power, as if we were *doomed* to unceasing improvement and development. Why is it so? I had been thinking about it ever since, if sometimes less intently amid everyday problems, but couldn’t find a clear answer.

And finally, when I was working meticulously on the dominant of “*personified cognitive feedback*”, on the final stage of work (about 2 years from the beginning) small “*flashes of correlation*” (according to B.F. Porshnev) or *displays of intuition*, which are ruled by a certain *dominant*, have merged into an insight. So, the major stages of PCFB evolution may be defined, which provide society’s advance to *progressively accelerated development*. It should however be noted that *the key creative element in this powerful process of creative integration and accumulation of knowledge is still the individual neural substance – the human brain*.

The major functions of the brain are acquiring and accumulating new information and its integration into the person’s individual cognitive potential with a certain purpose: either performing current everyday tasks, or solving professional problems, or prospective scientific research initiated by some fantasies or scientific dominants. Here a quote by an outstanding aircraft engineer Igor Sikorsky, which is engraved in his alma mater KPI, is to the point: “*An individual’s work is still the spark which moves the humanity forward, even more so than teamwork*”.

So, the whole experience of the humanity doubtlessly proves that the generalized cognitive potential of a community gradually forms during the long evolution of integrated knowledge synthesized by individual cognitive potentials of numerous people, generations, and most often by outstanding researchers and scientists. This is powerful cognitive potential created by humanity and accumulated in humanitarian and technical literature. So, let us estimate the major evolutionary stages for personified cognitive feedback.

### **6.1 Starting point**

We have already accepted the *evolvment of writing* as a powerful and multi-purpose model for generating, storing and accumulating knowledge for time periods much exceeding the existence of biological memory and, accordingly, a particular individual’s knowledge, as a starting point for the distinction between *a human being and an animal*. Actually, some kind of (solely oral) communication as a necessity for survival and fostering a new generation in any living population; however, it is limited to the life cycle of a particular individual or the population’s existence.

It should be emphasized again that writing has become a universal model for storing, accumulation and management of information about the real as well as virtual world, even if oral speech also has this capacity. The process of comparing the current status of the

living space as perceived by the sensory system to the accumulated experience (knowledge) kept in memory, which has been defined as personified cognitive feedback, is typical of any living creature. But the lifetime of the accumulated information is limited by the biological life of the creature's neural organization, or by the population's lifetime, if this information is somehow shared and accumulated in the population.

### **6.2 Evolution of Porshnev's dominant**

B.F. Porshnev has determined the major developmental vector among the vast amount of fragmented data on the development of a human being and a society, and this vector is defined by the fundamental thesis: *the history of humankind is a progressively accelerated process*. However, the lifelong dominant of his scientific research could not explain why it is so. Evolution of B.F. Porshnev's dominant is defined by consequent research of the correlations: "*A Human Being – Work*", "*We - They*", "*Friend – Foe*", "*A Person – A Person*" (where two neural substances "*Brain – Brain*" interact), and finally "*A Brain – Brains*", where an individual's cognitive potential is compared to the global cognitive potential of the community, represented by the total of printed and handwritten materials (on the symbolic level) as well as the whole potential of figural level information (music, theatre, painting, cinema etc).

With reference to evaluation of B.F. Porshnev's contribution to the research on these social relations by an expert for the legislative initiative supporting fund O.T. Vite [17] we may state that the major problem of the existing approaches is ignoring *the fundamental meaning of human speech*. In the prospectus for his book project "*People*" which has not been written B.F. Porshnev metaphorically defines the connection between an individual and a community: "*Just as the brain is composed of billions of cells, the conscience is composed of billions of brains... As brain neurons are connected by synapses, brains are connected by speech (the second signal system)*" [14]. It should be noted that by "*conscience*" he could mean the whole cognitive potential of the community, even without knowing how this creative potential is fulfilled.

A great leap for accumulation and development of the *global cognitive potential* is caused by evolvement and development of the world cognitive network: the INTERNET. Here the cognitive potential is accumulated every hour – or even faster. And the most important thing is free access to all this knowledge; this is the fundamental difference. Therefore, the next stage of the society's cognitive development may be recorded, defined by the correlation "*Brains – Brains*", which embraces the communities of INTERNET users. *This evolution of communicative processes determines the progressive acceleration of the society's development.*

### **6.3 Global cognitive feedback**

I have recently found an interesting thought regarding the essence of the global communicative system in the INTERNET: "*The world has acquired gazillions of data and the world of users*". It is a very reasonable thought in the context of our research, which adequately represents the relation between communities of authors who post the results of observations, thoughts and generalizations by their individual neural networks into the INTERNET, and the readers who use any information accumulated by humankind in this global network. This leads to an interesting conclusion: the cognitive potential of the society is actually created by integrating results of operation of a set of individual PCFBs covering the whole community. This thesis may be generalized as follows: *personified cognitive feedback of individual members of the community taken out of the biological neural network and recorded on electronic media, thanks to global access to the*

*INTERNET*, transforms into global cognitive feedback of the society which is free to access for all members of the community.

However, the major moving force for the development of *global cognitive potential* including the creative component and the function for generating new information by the canon of dominant and intuition is still the *individual personified cognitive feedback*, realized in living biological neural substance. The process of integrating a set of cognitive potentials of individual PCFs from the whole community and gradual translation of new information from the neural level to electronic media and, therefore, creation of the *global cognitive potential* defines the *progressive acceleration of the society's development*.

This process is reconstructed in Fig. 5, which represents the process of accumulation and development of the global cognitive potential, based on personified cognitive feedback of an individual member of the community. This feedback is essentially positive by nature with regard to accumulation and use of knowledge. This is what determines the progressive acceleration of the society's development. This structure actually demonstrates how the *global cognitive potential* which results from constant centuries-old (or even millennia-old) integration of individual cognitive potentials belonging to all members of human community, notwithstanding the variety of languages, is created and used.

The central (red) segment represents the set of "brains" of all community members, each of them creating their unique *individual cognitive potential (ICP)* within their living space, taking into account creative capabilities of PCFB; and a combination of these potentials creates, accumulates and complements the *global cognitive potential (GCP)* of the whole community via communicative channels (*external framing*). This potential is represented by literature, art, science etc. and is stored in museums, libraries, various archives and funds. Accumulation of and access to knowledge have changed dramatically as a result of development and use of the INTERNET. This has accelerated the society's development dramatically.

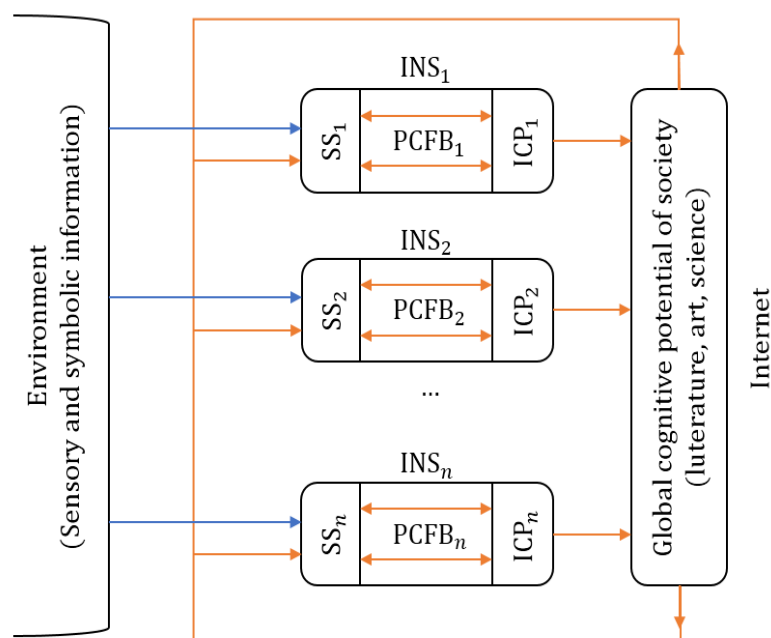

Fig. 5. Scheme of accumulation of global cognitive potential

$INS_i$  – individual speech system,  $ICP_i$  – individual cognitive potential,  $PCFB_i$  – personified cognitive feedback,  $n \rightarrow \infty$  and is determined by size of the population

The central (red) segment represents the set of “*brains*” of all community members, each of them creating their unique *individual cognitive potential (ICP)* within their living space, taking into account creative capabilities of PCFB; and a combination of these potentials creates, accumulates and complements the *global cognitive potential (GCP)* of the whole community via communicative channels (*external framing*). This potential is represented by literature, art, science etc. and is stored in museums, libraries, various archives and funds. Accumulation of and access to knowledge have changed dramatically as a result of development and use of the INTERNET. This has accelerated the society’s development dramatically.

So *the circle of positive cognitive feedback has closed*: a person “uses” all knowledge potential accumulated by the community, comparing it to their *individual cognitive potential*, but only within their own biological neural network, capable of the following information management models: associative search, generalization, conceptualization, integration of diverse information etc., which operate by the canons of thought, including presupposition, dominant and intuition.

*Combination of these two powerful phenomena: integration of knowledge accumulated by the whole community and presented in texts, manuscripts and other symbolic and visual forms and, especially, posted in the world cognitive network – the INTERNET, and their processing and interpretation in millions of living neural networks with consequent (cognitively renewed) return to the world wide web provides for positive cognitive feedback, which, in its turn, results in progressive acceleration of society’s development by means of two-directional associative link with analysis and synthesis of new information.* This explains B.F. Porshnev’s prediction regarding progressively accelerated development of the society – provided, of course, that humankind itself does not breach this universal law of development. The question yet to be answered is: *which laws regulate this acceleration and will the humankind survive it?*

Some major steps in humanity’s evolution may serve as examples of progressively accelerated development of the society. *On the one hand, these are the creative achievements: evolution of writing, invention of artificial sensory systems, which have made exploration of macro and micro worlds possible, creation of the global cognitive potential in the INTERNET, the HUMAN genome, SpaceX, discovery of new habitable planets and worlds; on the other hand, these achievements are alarmingly used against the human civilization’s prosperity and well-being.*

### **Conclusion**

The concept of personalized cognitive feedback (PCF) as the basic principle of the functioning of our neural network in the way of perception, accumulation and use of the cognitive potential of the person concerning the information of both figurative and symbolic levels is introduced in the work. The formal definition of a separate “*quantum of knowledge on the figurative level*” is introduced - a situation that is translated into a linguistic level by a separate basic semantic-syntactic structure of the BSSS - “*quantum of knowledge of the language level*”. PCF will always be considered positive - in terms of accumulation and correction of gained knowledge. In the living space of the existence of an individual, PCF gradually forms the *individual cognitive potential (ICP)*, which is actualized in the living neurosubstantium. Of course, the ICP is formed and adjusted throughout the life cycle of the individual, but the period of its existence is determined only by the biological life cycle. Separate ICPs, through communication tools, gradually

integrate into the Global Cognitive Community Potential (*GCP*), which practically outlines, in general, the vital credo of the population.

However, it is fundamentally important that in this case the evolution of the community (in terms of accumulation and utilization of information gains) takes place at an extremely slow pace; virtually, the transfer of information at the initial stage of populations formation occurs from one "living" neurosubstance to another - also "living" and any global cataclysms can break the accumulated *GCP* and bring the process to a standstill.

The principal moment in the development of the human race was the development of a written word, when the gains of the accumulated *GCP* are being transmitted to other media (bark, fireplaces and clay tablets, papyrus, paper, magnetic media, etc.) that allow storage, accumulation and transfer of knowledge for a period of time which is significantly longer than time of the existence of living neurosubstantia.

However, it should always be remembered that only a living neurosubstantium, with its powerful creative potential, is capable of integrating, conceptualizing and synthesizing new information. How not to mention here the words of Igor Sikorsky, written on the walls of his Alma-Mother - KPI: "The work of the person still remains the spark that drives humanity even more than collective labor".

### References

1. Chaplin J.P. Dictionary of psychology. – Laurel, 1985. – 528 p.
2. Кисленко Ю.І. Архітектура мови // Навчальний посібник. Київ, 1998. – 343 с.
3. Кисленко Ю.І. От мысли к знанию (нейрофизиологические основания). Изд. «Український літопис», Київ, 2008. – 102 с.
4. Kyslenko Y.I. Back to basics of speech activity / Y.I. Kyslenko // Biologically Inspired Cognitive Architectures. – 2014. – Vol. 8. – P. 46–68.
5. Щерба Л.В. Языковая система и речевая деятельность / Л.В. Щерба. – Ленинград: Наука, 1974. – 428 с.
6. Городецкий Б.Ю. Компьютерная лингвистика: моделирование языкового общения / Б.Ю. Городецкий // Новое в зарубежной лингвистике. – 1989. – № 24. – С. 5–31.
7. Zeki S. The visual image in mind and brain. / S. Zeki // Scientific American. – 1992. – Vol. 267. – P. 68–76.
8. Хокинс Дж. Об интеллекте. М.: ООО «И.Д. Вильяма», 2007. – 240 с.
9. Гвоздев А.Н. Формирование у ребенка грамматического строя русского языка / А.Н. Гвоздев. – Москва: АПН РСФСР, 1949. – 268 с.
10. Перцов Н. О некоторых проблемах современной семантики и компьютерной лингвистики / Н. Перцов // Московский лингвистический альманах. – 1996. – № 1. – С. 9–66.
11. Крышталь О.А. К пению птиц / О.А. Крышталь. – Санкт-Петербург: Борей Арт, 2001. – 300 с.
12. Лефевр В.А. Конфликтующие структуры / В.А. Лефевр. – Москва: Советское радио, 1973.
13. Ибука М. После трех уже поздно. – Издательство: Альпина нон-фикшн, 2018. – 223 с.
14. Поршнев Б.Ф. О начале человеческой истории (проблемы палеопсихологии) / Б.Ф. Поршнев. – Москва: Издательство "Мысль," 1974.
15. Ухтомский А.А. Доминанта. Статьи разных лет. 1887-1939 / А.А. Ухтомский. – СПб: Питер, 2002. – 448 с.
16. Губенко В.І. Знання і перетворення дійсності / В.І. Губенко. – Київ: Наукова думка, 1968. – 171 с.
17. Вите О.Т. Борис Федорович Поршнев и его критика человеческой истории [Электронный ресурс]. – Режим доступа: <http://annuaire-fr.narod.ru/statji/Vite-2005.html>
18. Рукописні матеріали [ОР РГБ.Ф.684.Картон 26.Ед.Хр.6П.1]
19. Кисленко Ю.І. О моделировании отношения «действительность – текст» / Ю.І. Кисленко, Г.А. Амплеева // Искусственный интеллект. – 2000. – № 3. – С. 475–487.
20. Кисленко Ю.І. Рекурсивный синтаксический анализатор / Ю.І. Кисленко // Науковий вісник кафедри ЮНЕСКО Київського державного лінгвістичного університету. - 2000. - № 1. - С. 157-164.

### References

1. Chaplin J.P. Dictionary of psychology. – Laurel, 1985. – 528 p.
2. Kyslenko Yu.I. Arkhitektura movy // Navchalnyi posibnyk. Kyiv, 1998. – 343 s.
3. Kyslenko Yu.I. Ot mysli k znaniyu (neyrofiziologicheskiye osnovaniya). Izd. «Ukrainskyi litopys». Kyiv, 2008. – 102 s.
4. Kyslenko Y.I. Back to basics of speech activity / Y.I. Kyslenko // Biologically Inspired Cognitive Architectures. – 2014. – Vol. 8. – P. 46–68.
5. Shcherba L.V. Yazykovaya sistema i rechevaya deyatelnost / L.V. Shcherba. – Leningrad: Nauka, 1974. – 428 s.
6. Gorodetskiy B.Yu. Kompyuternaya lingvistika: modelirovaniye yazykovogo obshcheniya / B.Yu. Gorodetskiy // Novoye v zarubezhnoy lingvistike. – 1989. – № 24. – S. 5–31.



7. Zeki S. The visual image in mind and brain. / S. Zeki // Scientific American. – 1992. – Vol. 267. – P. 68–76.
8. Khokins Dzh. Ob intellekte. M.: ООО «I.D. Viliama». 2007. – 240 s.
9. Gvozdev A.N. Formirovaniye u rebenka grammaticheskogo stroya russkogo yazyka / A.N. Gvozdev. – Moskva: APN RSFSR. 1949. – 268 s.
10. Pertsov N. O nekotorykh problemakh sovremennoy semantiki i kompyuternoy lingvistiki / N. Pertsov // Moskovskiy lingvisticheskiy almanakh. – 1996. – № 1. – S. 9–66.
11. Kryshchal O.A. K peniyu ptits / O.A. Kryshchal. – Sankt-Peterburg: Borey Art. 2001. – 300 s.
12. Lefevr V.A. Konfliktuyushchiye struktury / V.A. Lefevr. – Moskva: Sovetskoye radio. 1973.
13. Ibuka M. Posle trekh uzhe pozdno. – Izdatelstvo: Alpina non-fikshn. 2018. – 223 s.
14. Porshnev B.F. O nachale chelovecheskoy istorii (problemy paleopsikhologii) / B.F. Porshnev. – Moskva: Izdatelstvo “Mysl.” 1974.
15. Ukhtomskiy A.A. Dominanta. Stati raznykh let. 1887-1939 / A.A. Ukhtomskiy. – SPb: Piter. 2002. – 448 s.
16. Hubenko V.I. Znannia i peretvorennia diisnosti / V.I. Hubenko. – Kyiv: Naukova dumka, 1968. – 171 s.
17. Vite O.T. Boris Fedorovich Porshnev i ego kritika chelovecheskoy istorii [Elektronnyy resurs]. – Rezhim dostupa: <http://annuaire-fr.narod.ru/statji/Vite-2005.html>
18. Rukopysni materialy [OR RHB.F.684.Karton 26.Ed.Khr.6P.1]
19. Kyslenko Yu.I. O modelirovani otnosheniya «deystvitel'nost – tekst» / Yu.I. Kyslenko. G.A. Ampleyeva // Iskusstvennyy intellekt. – 2000. – № 3. – S. 475–487.
20. Kyslenko Yu.I. Rekursyvnyi syntaksicheskiy analizator / Yu.I. Kyslenko // Naukovyi visnyk kafedry YuNESKO Kyivskoho derzhavnoho linhvistychnoho universytetu. - 2000. - № 1. - S. 157-164.

## РЕЗЮМЕ

**Ю.І. Кисленко**

### **Персоніфікований когнітивний зворотний зв'язок як потужний важель прогресивного прискорення розвитку суспільства**

В роботі вводиться поняття персоніфікованого когнітивного зворотного зв'язку (ПКЗЗ) як схеми взаємодії інформації образного та символного рівнів, що сприймаються людиною, з накопиченим когнітивним потенціалом нашого мозку. Такий зворотний зв'язок завжди вважатимемо позитивним в плані поступового накопичення та корекції індивідуального когнітивного потенціалу. Головним чином ці процеси аналізуються на шляху функціонування індивідуальної мовної системи, введеної ще нашим співвітчизником Л. Щербою. Послідовно, з позицій урахування сучасних досягнень дослідження мовленнєвої діяльності у багатьох помежованих напрямках (нейрофізіологія, психологія, філософія, кібернетика) формується інтеграційний підхід, що зводить наші знання стосовно структурно-функціонального рівня мовної організації до чіткої системи, в основу якої покладена лише одна-єдина базова семантико-синтаксична структура, що постає похідною від структурно-функціонального рівня нейроорганізації зорового тракту.

З позицій інтроспективного аналізу розглядаються як окремі етапи опрацювання довільного мовного повідомлення, так і особливості вербалізації інформації образного характеру. Власне, ПКЗЗ і забезпечує процес «розуміння», зіставляючи як кожен складову, так і все нове повідомлення, з поточним когнітивним потенціалом реципієнта.

*Коли ж спроектувати особливості актуалізації індивідуального ПКЗЗ на суспільство загалом, то доходимо потужного висновку, що саме множина окремих індивідуальних ПКЗЗ спільноти з їх потужним креативним потенціалом та необмеженими можливостями комунікації і забезпечують формування та постійне зростання глобального когнітивного потенціалу, що, в свою чергу, власне і зумовлює прогресивне прискорення розвитку суспільства.*

*Надійшла до редакції 14.02.2018*