

PACS 42.55.Rz, 42.60.Jf, UDK 621.791.72.03

Characteristics of thermal lens induced in active rod of cw Nd:YAG laser

A. Khizhnyak ^a, G. Galich ^{b,1}, M. Lopiitchouk ^{b,2}

^a International center «Institute of Applied Optics» NAS Ukraine, 254053, Kyiv, Ukraine, phone 380(44)2122158, fax 380(44)2124812, e-mail: khizh@writeme.com

^b Institute of Physics National Academy of Sciences of Ukraine, 252650, Kyiv, Ukraine, phone 380(44)2654069, fax 380(44)2651589,

¹ e-mail: galich@iop.kiev.ua, ² e-mail: lopii@iop.kiev.ua

Abstract. The structure of thermal lens induced in active rod of cw Nd: YAG laser was investigated using the Mach-Zehnder interferometer and electronic speckle pattern interferometry (ESPI) system. It is shown that thermal lens has weak aberrations and coincides to the with that of parabolic lens. The se aberrations play role of perturbations and lead to the oscillation of all transversal modes that exceed the threshold of oscillation. It is shown that the change of the pumping level leads to thermal lens displacement and the changes of its principal planes.

Keywords: laser, thermal lens, interferometer.

Paper received 10.03.99; revised manuscript received 12.05.99; accepted for publication 24.05.99.

I. Introduction

High power cw Nd:YAG lasers are widely used in different industrial applications, especially for welding and cutting of metal sheets [1]. Therefore it is particularly important to predict the quality of output laser emission for the laser “under construction”, especially divergence, that is the basic parameter limiting the achievement of high density power on the working surface and decreasing the field of possible applications of such lasers. Widely used method for describing output laser beam based on the Wigner distribution function allows only to approximate the characteristics of the real laser beam, but can not be used in the stage of development of laser with purpose to predict the output parameters of laser [2].

Much work has been performed on cavities with a varying internal thermal lens induced in active medium in the last decades [3-4]. One should mark the work [4] where a modified matrix model for cavities with internal thermal lens and Gaussian diaphragm, which approximate a real apertures, was proposed for calculating divergence and diameter of output laser radiation. Such

method can be used in designing laser cavities with the purpose to obtain necessary divergence of output laser radiation using measurements of the thermal focal length of laser rod and the known dimensions of the real apertures.

This method [4] will be valid when the thermal lens is not far from perfect parabolic lens. Only in this case one knows structure modes – Hermite functions – and it's losses. In case when the strong aberration of thermal lens is present, the Hermite functions can not be used for describing cavity's modes. When one wants to estimate the losses and divergence of modes for cavity including aberration lens, it is necessary to fulfil complicated calculations that have not been fulfilled up to date. Obviously, since Hermite functions form complete sets, one should be able to express the field of arbitrary laser beam in terms of those functions. But on this way we can only approximate the real laser beam, as well as we use the Wigner distribution function, and can not predict the output characteristics of laser emission.

The calculated results performed for two types of lasers in work [4] were in a good agreement with experimental results. It indicates applicability of describing the thermal lens as perfect parabolic lens, at least, for laser cavities investigated by the authors of this work.

As the main parameter – the thermal focal length of laser rod – must be tested before designing the cavity. Different methods are used for measurements of the thermal focal length of laser rod. Usually, the testing beam of He-Ne laser with a plane wavefront is used for these measurements. The focal length is determined by measurements of the testing laser beam spot diameter in two positions after laser rod or in the focal plane of the additional lens placed near laser rod [5]. It is evident, that such methods allow to determine only the average focal length but do not allow to estimate the aberrations of thermal lens.

In this paper, we fulfil the direct measurements of the wave front structure of the testing He-Ne laser beam passing through the pumping laser rod. For this purpose we used phase-shifting interferometry method [6]. Describing in [7] method based on the Hartmann wavefront sensor can be used for such measurements, but it is insensitive when a jump of phase of the wavefront takes place.

II. Experimental Set-up

The active rod $\varnothing 6.3 \times 100$ mm (1) in the single lamp pumping cavity (2) was placed in one leg of the Mach-Zehnder interferometer (3) (Fig. 1). The telescope with pinhole (4) expanded the emission of He-Ne laser (5). The mirror in the free leg of the interferometer was mounted on the piezoelectric drive (6) creating the determined phase shift between two beams of interferometer. The lens (7) creates the image of the active rod's end surface on the CCD camera (8). The iris diaphragm (9) placing in the focal plane of this lens and filters (10) was

used for protection of the CCD camera from the emission of the pumping lamp. Without pumping, the interferometer was aligned for obtaining of unlimited width fringes.

Hardware and software worked up for the electronic speckle interferometry system [6] was used for stored and analysis of interferograms and control for piezoelectric drive. The system automatically stores three images of interferograms with the phase shift equal $0, \pm 2\pi/3$ between two beams passed through the interferometer. It allows to determine the real wavefront of the beam passed through the pumping active rod. This wave front is equal to phase delay produced by the pumping active rod and therefore can be used for describing of equivalent thermal lens induced in active rod.

In addition to described above method of measurements of the wave-front structure of the testing laser beam, we used the traditional method of measurement of the thermal lens focal length – measurements of testing laser beam spot diameter in two positions after laser rod.

III. Discussion of the experimental results

Fig. 2 shows the views of the wavefront of the beam with initially plane wave-front passed through the active rod with the different pumping current and it's cross sections along x-axis. We have found a least-square fit of the wave front experimental data (matrix 364×250) using the 4-degree polynomial:

$$W(x, y) = \sum_{m=0}^4 \sum_{n=0}^4 c_{m,n} x^m y^n, \quad (1)$$

where \sum' means the sum for n satisfying the inequality $n + m \leq 4$, the center of coordinate system (X, Y) is the geometrical center of active rod. The coefficients of fit-

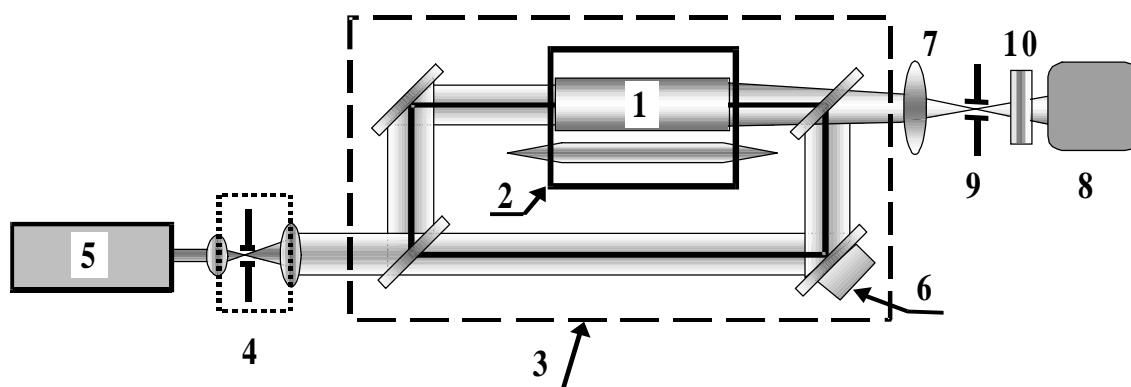

Fig. 1. Experimental set-up for measurements of the wave front perturbations of the testing beam passing through the pumping laser rod: 1 – laser rod; 2 – pumping cavity; 3 – Mach-Zehnder interferometer; 4 – telescope with pinhole; 5 – He-Ne laser; 6 – piezoelectric drive; 7 – lens; 8 – CCD camera; 9 – iris diaphragm; 10 – light filters.

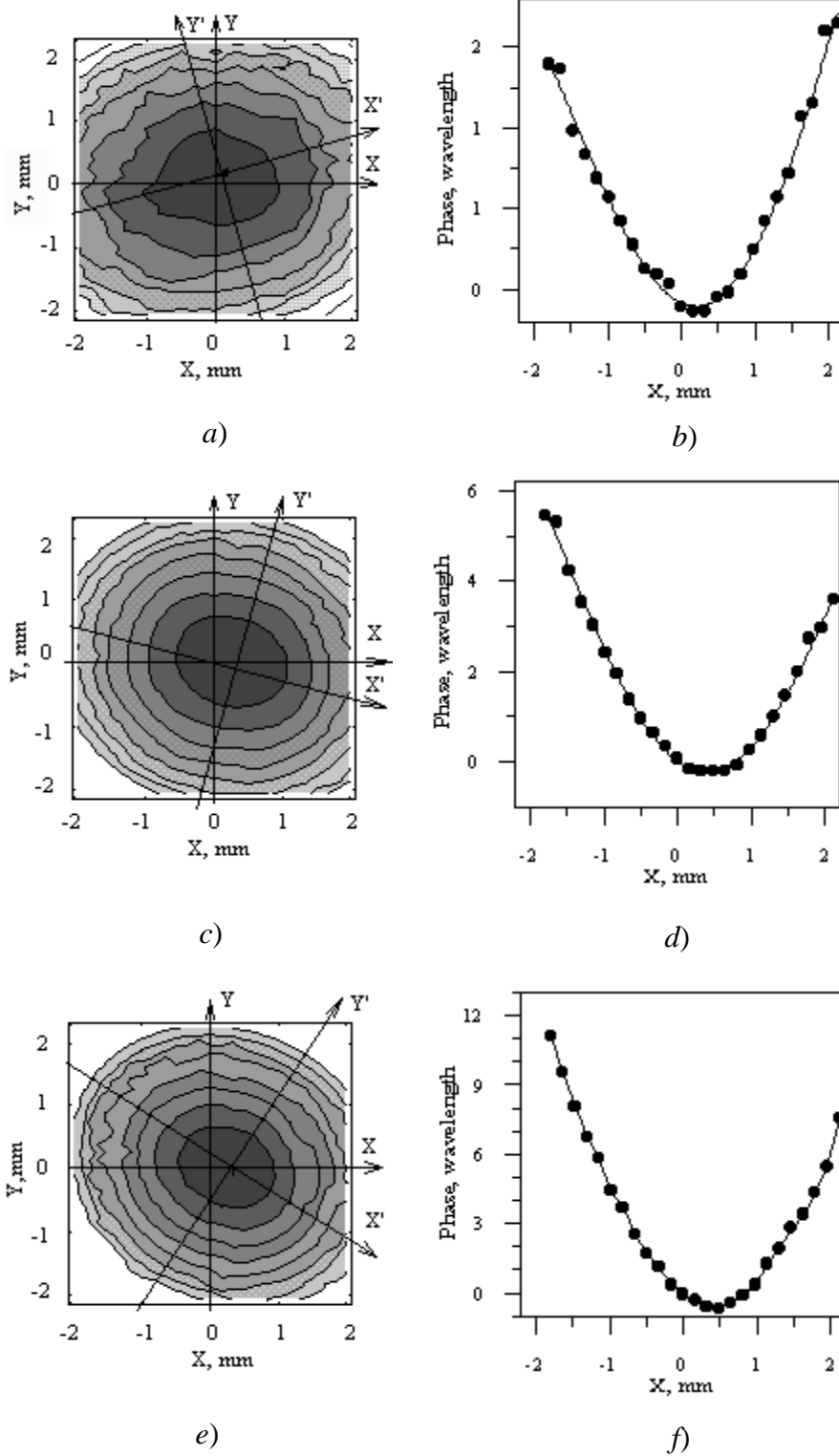

Fig. 2. Contour plots of the wavefront of the testing beam passed through the Nd:YAG rod with different pumping currents 9A, 20A, 30A respectively (*a*, *c*, *e*), and their cross section along *x* axis (dots) and polynomial fitting (solid line) (*b*, *d*, *f*); wavelength is equal to 623 nm.

ting C_{nm} are shown in Tab. 1. The coefficients C_{nm} in Tab. 2 were found for new coordinate system (X', Y') associated with the center of thermal lens and its principal axes. This change of the coordinate system allows to avoid the influence of thermal lens displacement and the changes of its principal planes (to compare the coefficients C_{01} , C_{10} and C_{11} in Tabs. 1 and 2, the first two ones describe the tilt of the testing wavefront).

These pictures (Fig. 2 a, c, e) show that thermal lens behavior is very complicated – its center is displaced and principal planes are rotated. It means that the configuration of the cavity with this lens inside depends on the pumping level by complicated law. The optical axis of this astigmatic cavitis displaced and its principal axes are rotated when the pumping power is changed. Of course, these displacements and rotations will be different for various pumping cavities, but the knowledge about it may be taken into account in a stage such designing of laser cavity. In the case when initial diaphragm is placed in the laser cavity, its position has to be chosen according to displacements of the optical axis of the cavity.

The approximation (1) allows to estimate the deviations of thermal lens from a perfect parabolic lens. All results show that the wavefront is smooth enough, and,

to first order, the perfect parabolic lens can be used for the description of the thermal lens in the active rod. The deviations, such as a spherical aberration (coefficients C_{04} and C_{40}) can be considered as perturbation.

Since the coefficients in fitting (1), except C_{20} and C_{02} , are smaller than C_{20} or C_{02} , so we can write the transmission coefficient of the active rod (it describes the active rod only as lens and does not include the gain) in the next form:

$$T(x, y) \approx \exp\left[i\left(C_{20}x^2 + C_{02}y^2\right)\right] \left\{1 + i \sum_{m \neq 2}^4 \sum_{n \neq 2}^4 C_{nm} x^m y^n\right\}, (2)$$

where the exponent for the terms with $C_{nm} \ll C_{02}, C_{20}$ was replaced by their power series of the first order and their products were neglected. Furthermore, in a first approximation, we can neglect the second component in the brackets of expressions (2).

It leads to the problem of calculating the eigenmodes of the cavity with the perfect, in common case, astigmatic lens, which is described by exponent in (2). In the case of laser resonator having the infinite apertures or the Gaussian transmission apertures, the eigenmodes problem can be readily solved, and, as known, the modes of such cavity are described by the Hermite functions [8].

Table 1. Coefficients of the polynomial fitting for the testing beam wavefront.

I, A	C_{00}	C_{10}	C_{20}	C_{30}	C_{40}	C_{11}	C_{12}	C_{13}	C_{21}	C_{22}	C_{31}	C_{01}	C_{02}	C_{03}	C_{04}
9	0.11	0.29	2.80	0.02	0.01	0.60	0.01	0.01	0.03	0.05	0.01	0.34	3.73	0.02	0.03
15	0.06	0.11	6.35	0.05	0.01	0.71	0.03	0.02	0.01	0.08	0.03	0.46	7.20	0.09	0.03
20	0.07	0.85	8.03	0.02	0.06	1.51	0.06	0.01	0.02	0.02	0.04	0.31	8.52	0.07	0.04
25	0.29	0.99	10.7	0.0	0.15	2.36	0.09	0.08	0.05	0.05	0.05	0.87	10.8	0.09	0.09
30	0.28	3.02	14.9	0.01	0.06	3.68	0.19	0.09	0.27	0.05	0.09	0.74	15.3	0.18	0.19

Table 2. Coefficients of the polynomial fitting for the testing beam wavefront in the coordinate system associated with the thermal lens.

I, A	C_{00}	C_{10}	C_{20}	C_{30}	C_{40}	C_{11}	C_{12}	C_{13}	C_{21}	C_{22}	C_{31}	C_{01}	C_{02}	C_{03}	C_{04}
9	0.12	0.0	2.71	0.01	0.01	0.0	0.05	0.0	0.03	0.04	0.01	0.0	3.82	0.0	0.03
15	0.07	0.0	6.23	0.04	0.01	0.0	0.09	0.05	0.08	0.05	0.04	0.0	7.33	0.06	0.04
20	0.09	0.08	7.49	0.02	0.02	0.02	0.09	0.02	0.09	0.15	0.03	0.04	9.07	0.0	0.03
25	0.33	0.0	9.59	0.04	0.08	0.01	0.12	0.10	0.11	0.34	0.01	0.0	11.9	0.02	0.06
30	0.45	0.0	13.3	0.01	0.06	0.0	0.21	0.06	0.31	0.37	0.19	0.0	17.0	0.07	0.08

We can split up coordinates and have two systems of eigenmodes – one is functions of X' and second – of Y' .

In the framework of such approach, the aberrations of the thermal lens play the role of the perturbations and may be taken into account by the theory of perturbations [8]. So far as a second component in the parenthesis of expressions (2) is polynomial, then the matrix elements of the perturbation operator describe the field propagation through the resonator [8]:

$$a_{kl} \sim \int U_k \exp[iC_{20}x^2] x^m U_l dx, \quad (3)$$

where U_k and U_l are modes of the unperturbed resonators (Hermite functions), can be easily found. When some astigmatism of thermal lens is present, and we can not neglect the terms with $x^n y^m$, where $n \wedge m \neq 0$, the next components of matrix elements of the perturbation operator will be present:

$$a_{kl} \sim \int U_k \exp[i(C_{20}x^2 + C_{02}y^2)] x^m y^n U_l dx dy \quad (4)$$

It leads to the connection of the se two eigenmodes types that were mentioned above. As a result, it may be shown that the measured values of the thermal lens aberrations do not change the structure of modes, but lead to their consequent transformation in each other. Finally, the weak lens aberrations lead to effective excitations of the maximally available quantity of the transverse resonator modes.

So far as the real laser cavity always has masking aperture, which acts as the additional source of losses even for the transverse modes with the lowest indexes - a part of their energy transforms into the higher modes where it will be lost on the masking aperture. However, even using geometrical optics approximation, without cumbersome computations on the base of the theory of perturbation, it allows to see easily that in case of the small aberrations of the thermal lens this process of energy losses will not be catastrophically increased as the rays of the modes with higher quality factor will have been confined in a limited volume during rather long time.

The fact of aberration littleness is very important, because we can consider that the structure of modes of the cavity with such thermal lens coincides with the structure of the cavity modes with a perfect parabolic lens. Consequently, we can use the method proposed in the work [4] that the considers the losses and the divergence of modes to be the same as for ideal cavity.

Fig. 3 demonstrates the dependencies of the lens focal length versus the pumping level measured by different methods mentioned above. The comparison of these dependencies shows that it is possible and sufficient to use the traditional method of measurements of the thermal lens focal length for calculating the output laser parameters. It, once again, proves the conclusion- the thermal lens of active rod are not far from the perfect parabolic lens.

In such a way, the fulfilled measurements show that

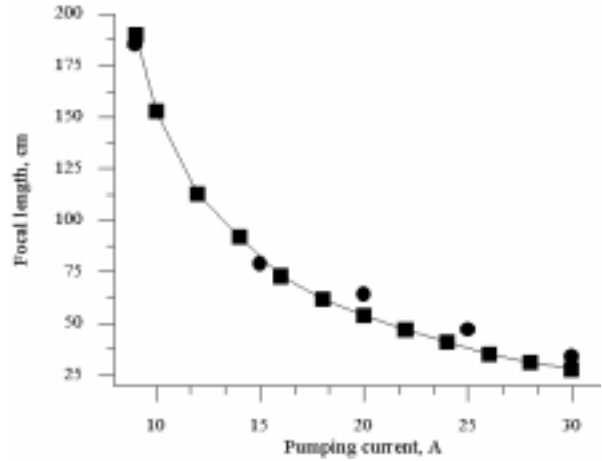

Fig. 3. Focal length versus pumping current measured by two methods : square – interferometry measurements; circle – traditional measurements of focal length.

the thermal lens induced in the cylindrical active element has weak aberration. It would be desirable to investigate the resonator performance and take into account the influence of birefringence – differences between the lens of active rod for different polarization.

IV. Conclusion

Using ESPI system one can clear up the new peculiarities in behavior of the thermal lens. It was known that the appearance of the optical wedge, the induced thermal lens and changing their power took place in active rod when the pumping power is changed. It was found, in addition to these features, that the displacement and the rotation of the principal axes of the thermal lens also took place when the pumping power is changed.

The described method allows to determine all characteristics of the thermoinduced optical distortions in the active rod of the real pumping cavity. Knowledge of those features allows to chose the necessary pumping cavity, to fulfil the realigning of the laser cavity in a due manner by using automatic system of adjusting with changing pumping power.

Acknowledgment

The authors are grateful to N. Burykin and V. Ovsyanikov from the International center «Institute of Applied Optics» National Academy of Sciences of Ukraine for providing us the EPSI system and for fruitful discussions. This work was supported by the Science and Technology Center in Ukraine, project number 526.

References

1. T. Ishide, O. Matsumoto, Ya. Nagura, T. Nagashima, Optical fiber transmission of 2 kW cw YAG laser and its practical application to welding // *High-Power Solid State Laser and Applications, SPIE Proc.* **1277**, pp. 188-198 (1990).
2. A. Khiznyak, M. Lopiitchouk, I. Peshko. Lens transformations of high power solid-state laser beams // *Opt. Laser Technol.* **30**(6), pp. 341-348 (1998).
3. N. Hodgson, H. Weber. Influence of Spherical Aberration of the Active Medium on the Performance of Nd:YAG Lasers // *IEEE J. of Quantum Electron.* **29**(9), pp. 2497-2507 (1993).
4. V. V. Apollonov, V. V. Kiiko, V. I. Kislov, Divergence of the radiation from a solid-state laser with a stable cavity and with intracavity apertures // *Quantum Electronics (Russia)*, **26**(11), pp. 974-977 (1996).
5. U. L. Kopylov, Interferometry—method of measurement of thermal lens focal length in active elements of solid state lasers // *Practice and Technique of Experiment (Russia)*, No.1, pp. 195-196 (1979).
6. P. M. Boone, V. B. Markov, N. M. Burykin, V. V. Ovsyannikov, Coherent-optical localization and assessment of importance of damage and defects of cultural heritage // *NDE&E International*, **30**(2), pp. 61-67 (1997).
7. D. J. Armstrong, J. D. Mansell, D. R. Neal, How to avoid beam distortion in solid-state laser design // *Laser Focus World*, Vol. 34, No. 12, pp.129-133 (1998).
8. Yu. A. Anan'ev, *Optical cavities and laser beams*, Nauka, Moscow, p.264 (1990).